

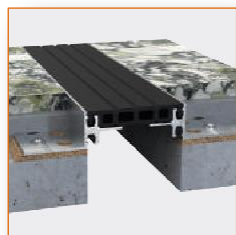

- Juntas para pavimento
- Juntas sísmicas
- Juntas para paredes e tetos
- Bandas corta-fogo
- juntas de movimento
- Juntas industriais
- Juntas estanques
- Juntas de cobertura
- Juntas de estacionamento

Catálogo geral de Juntas de dilatação
General catalogue of expansion joints





JUNTAS DE PAVIMENTO, PAREDE, JUNTAS DE TETO

Junta de dilatação econômica - adequadas para cargas de pedestres e veículos leves

GASKETED FLOOR, WALL, CEILING PROFILES

Economic expansion joint profiles-suitable for pedestrian load and light vehicle loads.

 PAGE
07-25

JUNTAS PARA PAVIMENTOS, PAREDES E FORROS

As junta de dilatação de mola parafusada ou de aço de um lado, são usadas em aplicações para paredes ou tetos brutos de cimento.

FLOOR, WALL, CEILING COVER PROFILES

One sided screwed or steel spring expansion joint profiles are used in applications for gross concrete walls or ceilings.

 PAGE
26-29

JUNTAS DE PAVIMENTO, PAREDE E TETO DA SÉRIE 300

A composição das juntas de alumínio e as juntas de dilatação inseridas em TPE são adequadas para centros comerciais, estruturas industriais leves, armazéns, hospitais, aeroportos e estações de metro. Adequada para locais onde a carga do veículo é leve a média e intensa carga de pedestres.

300 SERIES FLOOR, WALL AND CEILING PROFILES

Composition of aluminium profiles and TPE inserted expansion joint profiles are suitable for shopping centres, light industrial structures, warehouses, hospitals, airports and metro stations. Suitable to places where subjected light to medium vehicle load and intense pedestrian load.

 PAGE
30-37



JUNTAS HIGIÊNICAS DE JUNTAS DE DILATAÇÃO PARA SERVIÇOS PESADOS

As juntas de dilatação COR 700 e 800 e as juntas de pavimento do tipo sinus são resistentes a cargas pesadas. Eles são aplicados perfeitamente em centros comerciais, hospitais, edifícios industriais e etc. com suas estruturas higiênicas e decorativas.

HEAVY DUTY HYGIENIC EXPANSION JOINT PROFILES

COR 700 and 800 series of expansion joint profiles and sinus type floor profiles are resistant to heavy loads. They are perfectly performed at shopping malls, hospitals, industrial buildings and etc. with their hygienic and decorative structures.

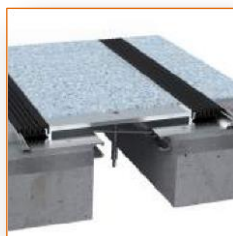
 PAGE
38-49



JUNTAS SÍSMICAS DE PISO, PAREDE E TETO

As juntas de dilatação sísmica têm alta capacidade de movimento e podem ser facilmente aplicados a grandes folgas. Adequado para muitos tipos de revestimento de pavimentos.

SEISMIC FLOOR, WALL AND CEILING PROFILES

Seismic expansion joint profiles have high movement capacity and can easily be applied to large gaps. Suitable for many types of floor coverings.

PAGE
50-69



JUNTAS DE DILATAÇÃO DE ESTACIONAMENTO

A composição das juntas de dilatação de borracha, aço e alumínio é amortecedora (silenciosa) e ideal para projetos de estacionamento.

CARPARK EXPANSION JOINT PROFILES

Composition of rubber, steel and aluminium car park expansion joint profiles are sound dampen (silent) and ideal for carpark projects

PAGE
70-77



JUNTAS COMPLETAS JUNTAS DE DILATAÇÃO ESTANQUES

Estas junta de dilatação são usadas em áreas úmidas, terraços e estacionamentos abertos onde são submetidas à água. Elas são facilmente usadas com materiais de isolamento.

COMPLETE WATERTIGHT EXPANSION JOINT PROFILES

These expansion joint profiles are used in wet areas, terraces and open car parks where subjected to water. They are easily used with isolation materials.

PAGE
78-95



JUNTAS DE MOVIMENTO

As juntas de movimento são projetadas para evitar rachaduras nos pavimentos de cerâmica ou granito devido à dilatação devido ao clima quente. Eles podem ser usados para áreas internas e externas.

MOVEMENT JOINT PROFILES

Movement joint profiles are designed to avoid cracks in ceramic or granite floors because of expansion due to hot weather. They can be used for both internal and external areas.

PAGE
96-101



JUNTA PARA LAJE DE CONTROLE DE CONTRAÇÃO E FISSURAS

O produto de junta de placa de aço ajuda a resolver a junta dentro de 7 a 14 dias por si só. É usado como alternativa a qualquer corte manual extra em aplicações de betão de laje.

SHRINKAGE AND CRACK CONTROL SLAB JOINT

Steel slab joint product helps to settle the joint within 7 to 14 days by itself only. It is used as alternative to any extra manual cuttings on slab concrete applications.

PAGE
102-105



BARREIRAS CONTRA INCÊNDIO E ÁGUA

Diferentes tipos de barreiras hidrofex e contra incêndio projetadas para parar a água e o fogo nas áreas das juntas de dilatação.

FIRE AND WATER BARRIERS

Different type of hydroflex and fire barriers designed to stop the water and fire in expansion joint profile areas.

PAGE
106-114

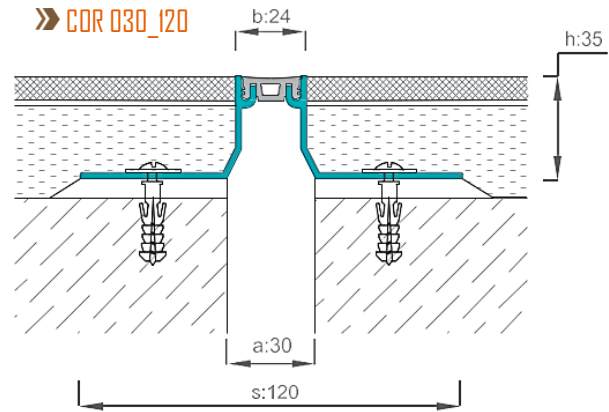
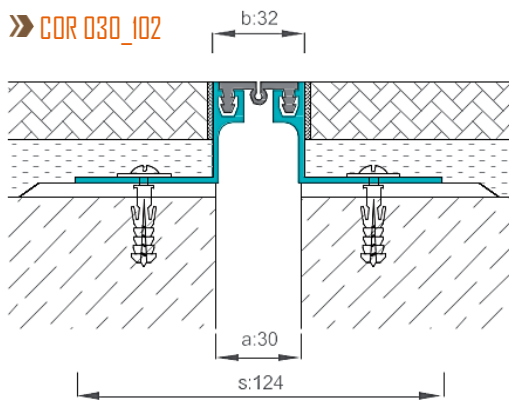
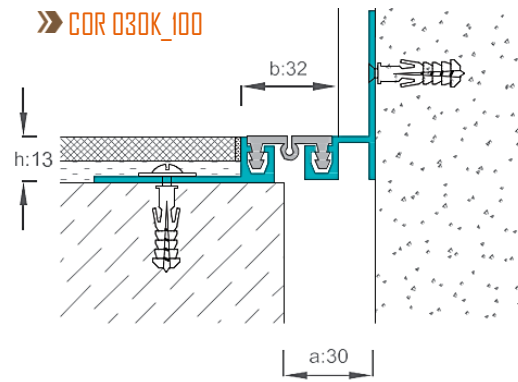
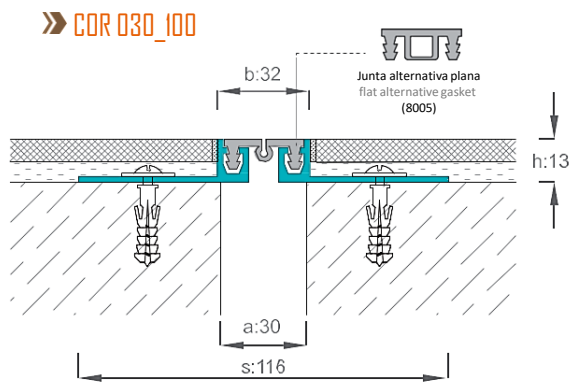
**CORES DA JUNTA /
GASKET COLOURS**

 Tipo de junta de pavimento
 parede e teto
 gasket type: floor, wall,
 Ceiling profiles

Com vedação intermediária sob a dilatação do pavimento final, as juntas são adequadas para intervalos de 30 mm. Podem ser usadas em diferentes níveis de revestimento de pavimentos, como cerâmica, granito, mosaico e betonilha. Geralmente aplicada em áreas de carga de pedestres e de carga de veículos leves (não intensos) (h: 26mm e acima). Montado no chão de ambos os lados, com um espaçamento de 35 cm com âncoras e parafusos adequados. A alternativa de vedação lisa deve ser usada em áreas higiênicas

Middle gasketed under finish floor expansion, joint profiles are suitable for 30mm gaps. Can be used in different levels of floor coverings such as ceramic, granite, mosaic and screed. Usually applied to pedestrian load and light vehicle load (not intense) areas (h:26mm and above). Mounted to floor from both sides by having 35cm spacing with appropriate anchors and screws. Smooth gasket alternative should be used in hygienic areas.



REF	DESCRIÇÃO DESCRIPTION	LARGURA DA JUNTA (a) mm JOINT WIDTH	SUPERFÍCIE VISÍVEL (b) mm SURFACE VISIBLE	ALTURA (h) mm PROFILE HEIGHT	LARGURA (s) mm TOTAL WIDTH	SUPERFÍCIE SURFACE	CAPACIDADE MOVIMENTO MOVEMENT CAPACITY	CAPACIDADE CARGA LOAD CAPACITY
COR_030_100	Usado em cerâmica, adequado 8-10mm Used in ceramic, suitable 8-10mm	30	32	13	116	Acabamento Alu + TPE Mill finish ALU + TPE	± 10	
COR_031_100	Usado em cerâmica, adequado 12-14mm Used in ceramic, suitable 8-10mm	30	32	20	100	Acabamento Alu + TPE Mill finish ALU + TPE	± 10	
COR_030_101	Adequado para granito natural, mármore, etc Suitable for natural granite, marble etc.	30	32	26	116	Acabamento Alu + TPE Mill finish ALU + TPE	± 10	
COR_030_102	Adequado para granito, mármore, etc Suitable for granite, marble etc.	30	32	35	124	Acabamento Alu + TPE Mill finish ALU + TPE	± 10	
COR_030_103	Adequado para pavimentos industriais, granito, etc Suitable for industrial floors, granite, etc.	30	32	50	124	Acabamento Alu + TPE Mill finish ALU + TPE	± 10	
COR_030_120	Adequado para cerâmica, mármore, etc Suitable for ceramic, marble etc.	30	32	35	120	Acabamento Alu + TPE Mill finish ALU + TPE	± 5	

**CORES DA JUNTA /
GASKET COLOURS**

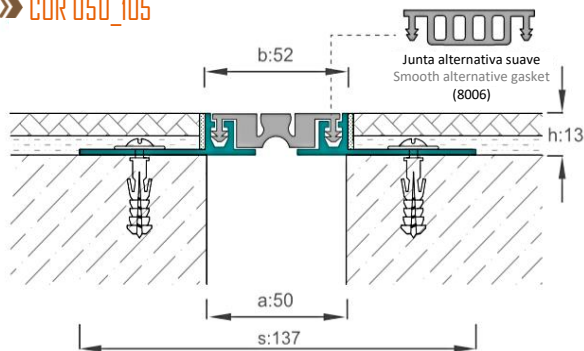
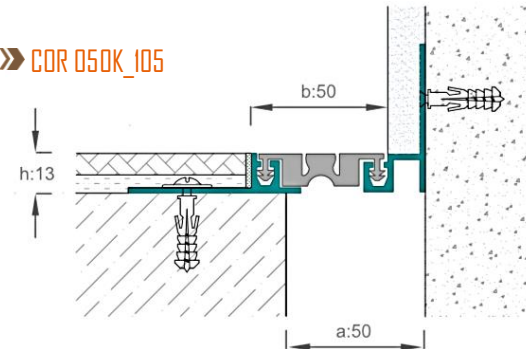
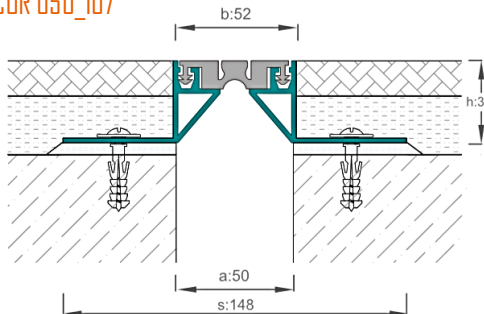
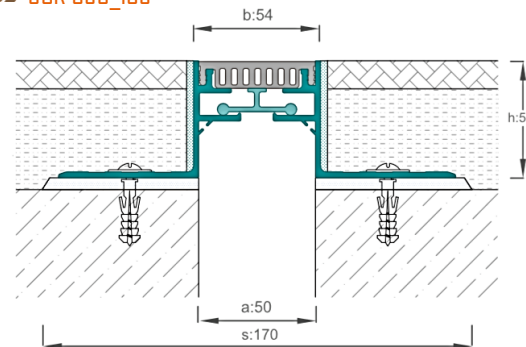
» COR 050_105

» COR 050K_105

» COR 050_107

» COR 050_109

 Tipo de junta de pavimento
 parede e teto
 gasket type: floor, wall,
 Ceiling profiles

Juntas de dilatação do pavimento com gaxeta são adequados para folgas de 50 mm. Pode ser usado em todas as coberturas de pavimentos em diferentes alturas. A alternativa de junta lisa também está disponível. Montado no chão de ambos os lados, com um espaçamento de 35 cm com âncoras e parafusos apropriados.

Gasketed under finish floor expansion joint profiles are suitable for 50mm gaps. Can be used in all floor covers at different heights. Smooth gasket alternative is also available. Mounted to floor from both sides by having 35cm spacing with appropriate anchors and screws.



REF	DESCRIÇÃO DESCRIPTION	LARGURA DA JUNTA (a) mm JOINT WIDTH	SUPERFÍCIE VISÍVEL (b) mm SURFACE VISIBLE	ALTURA (h) mm PROFILE HEIGHT	LARGURA (s) mm TOTAL WIDTH	SUPERFÍCIE SURFACE	CAPACIDADE MOVIMENTO MOVEMENT CAPACITY	CAPACIDADE CARGA LOAD CAPACITY
COR_050_105	Adequado para 8-10mm de cerâmica Suitable for 8-10mm ceramic	50	52	13	137	Acabamento Alu + TPE Mill finish ALU + TPE	± 10	
COR_050_106	Adequado para granito natural, mármore etc Suitable for natural granite, marble etc	50	52	26	136	Acabamento Alu + TPE Mill finish ALU + TPE	± 10	2,5 Ton
COR_050_107	Adequado para granito natural, mármore, betonilha etc. Suitable for Natural granite, marble and etc.	50	52	35	148	Acabamento Alu + TPE Mill finish ALU + TPE	± 10	2,5 Ton 2 Ton
COR_051_107	Adequado para granito, mármore e etc (económico). Suitable for granite, marble and etc (economic).	50	52	35	134	Acabamento Alu + TPE Mill finish ALU + TPE	± 10	
COR_052_107	Adequado para revestimentos de pavimentos em PVC. Suitable with PVC floor coverings	50	60	35	146	Acabamento Alu + TPE Mill finish ALU + TPE	± 10	2,5 Ton 2 Ton
COR_053_107	Adequado para granito natural, mármore, betonilha etc. Suitable for Natural granite, marble and etc.	50	52	50	148	Acabamento Alu + TPE Mill finish ALU + TPE	± 10	2,5 Ton
COR_054_107	Adequado para granito natural, mármore, betonilha etc. Suitable for Natural granite, marble and etc.	50	52	50	149	Acabamento Alu + TPE Mill finish ALU + TPE	± 10	2,5 Ton 2 Ton
COR_050_109	Adequado para granito natural, mármore, betonilha (superf. plana) Suitable for Natural granite, marble, screed etc. (Flat surface)	50	54	50	170	Acabamento Alu + TPE Mill finish ALU + TPE	± 10	

Juntas de dilatação de pavimento de embutir
Flush mounted floor expansion joint profiles

**CORES DA JUNTA /
GASKET COLOURS**

PRETO
BLACK
 CINZA
GREY
 CREME
CREAM

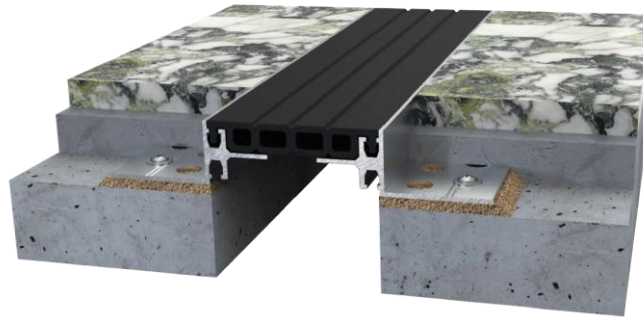

SUITABLE FOR
GAPS

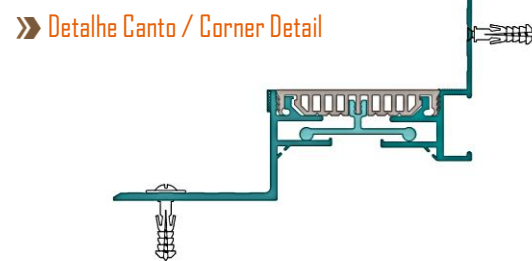
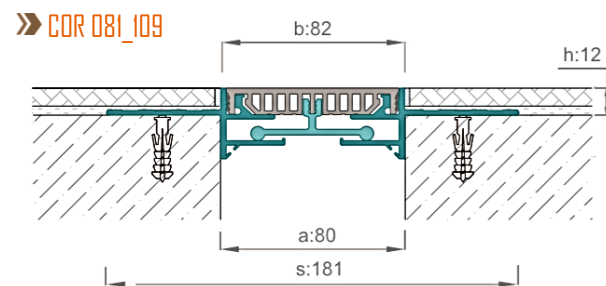
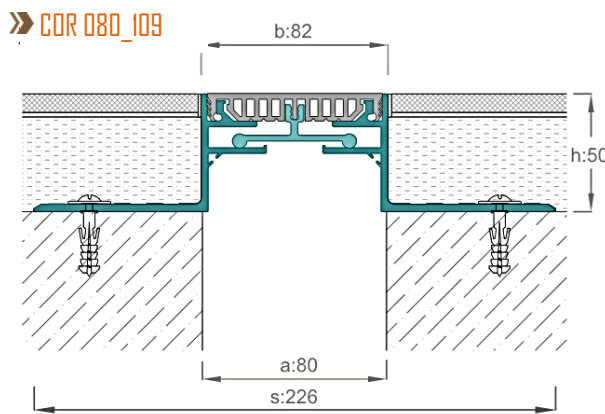
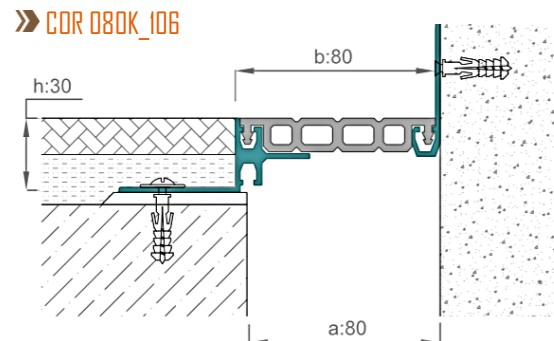
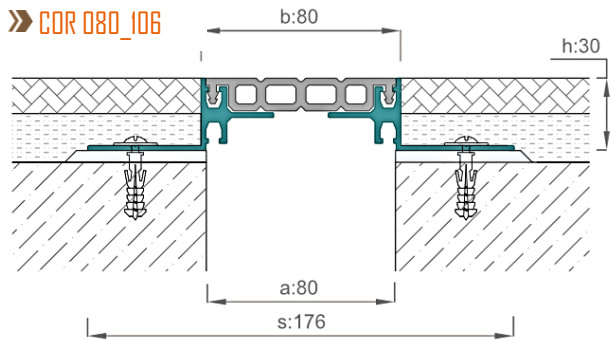

Tipo de Junta de pavimento
parede e teto
gasket type: floor, wall,
Ceiling profiles

Juntas de dilatação com acabamento adequado para intervalos de 80 mm. Utilizado em áreas onde está sujeito a carga de pedestres.
Under finish expansion joint profiles suitable for 80mm gaps. Utilized in areas where subjected to pedestrian load.

REF	DESCRIÇÃO DESCRIPTION	LARGURA DA JUNTA (a) mm JOINT WIDTH	SUPERFÍCIE VISÍVEL (b) mm SURFACE VISIBLE	ALTURA (h) mm PROFILE HEIGHT	LARGURA (s) mm TOTAL WIDTH	SUPERFÍCIE SURFACE	CAPACIDADE MOVIMENTO MOVEMENT CAPACITY	CAPACIDADE CARGA LOAD CAPACITY
COR_080_106	Adequado para superfície superior plana, granito, mármore etc. Suitable for flat top surface, granite, marble etc.	80	80	30	176	Acabamento Alu + TPE Mill finish ALU + TPE	± 10	
COR_080_109	Adequado para revestimentos decorativos higiénicos Suitable for decorative, hygienic coverings	80	82	50	226	Acabamento Alu + TPE Mill finish ALU + TPE	± 10	
COR_081_109	Adequado para revestimentos de 8 a 10mm. Suitable for 8 to 10mm coverings...	80	82	12	181	Acabamento Alu + TPE Mill finish ALU + TPE	± 10	
COR_100_106	Adequado para cerâmica, mármore, etc. Suitable for ceramic, marble, etc.	100	100	30	200	Acabamento Alu + TPE Mill finish ALU + TPE	± 15	
COR_100_734	Adequado para estacionamentos abertos e fechados, asfalto, etc. Suitable for open-closed carparks, screed asphalt etc.	100	150	50	240	Acabamento Alu + TPE Mill finish ALU + TPE	± 50	30 Ton

**CORES DA JUNTA /
GASKET COLOURS**



» COR 100_106

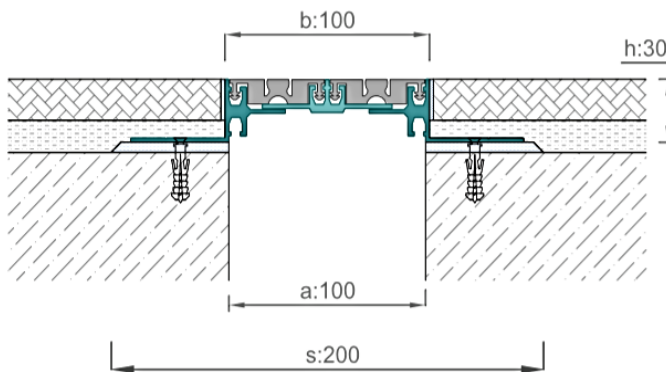

» COR 100K_106

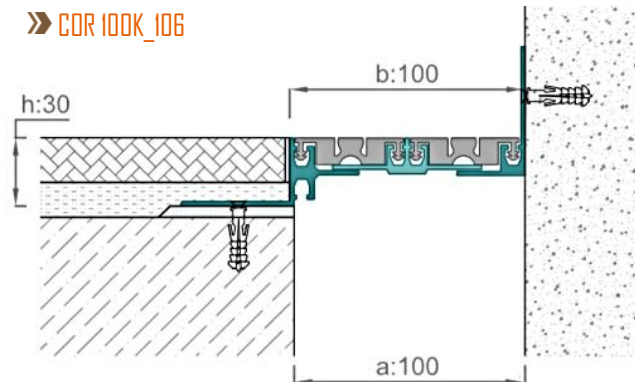

» COR 100_734

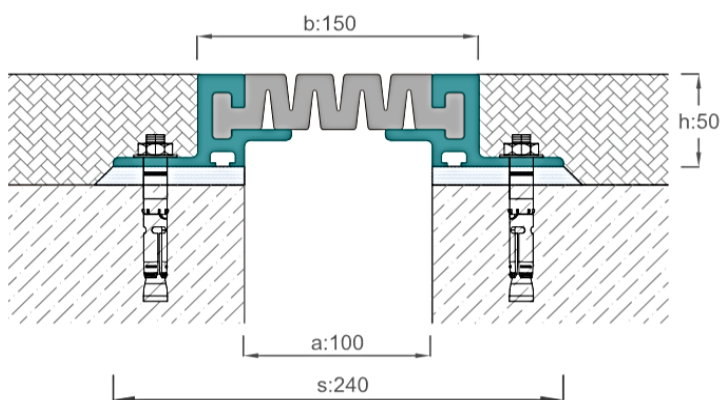

» COR 100K_734

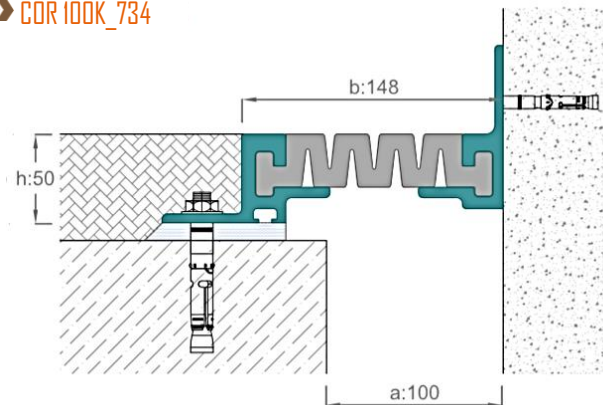

Tipo de Junta de pavimento
parede e teto
gasket type: floor, wall,
Ceiling profiles

Juntas de dilatação sob acabamento especial são utilizadas normalmente para uma folga de 100 mm. Utilizável para diferentes níveis em revestimentos de cerâmica, granito, mosaico e contrapiso. O COR 100_734 é adequado para carga do veículo. Também pode ser usado em aplicações de estacionamento. Under finish expansion joint profiles with special gasket are used for 100mm gap. Usable for different levels in ceramic, granite, mosaic and screed type floor covers. COR 100_734 is suitable for vehicle load. Can also be used in carpark applications.



**CORES DA JUNTA /
GASKET COLOURS**

PRETO
BLACK

CINZA
GREY

CREME
CREAM



» COR 030_152

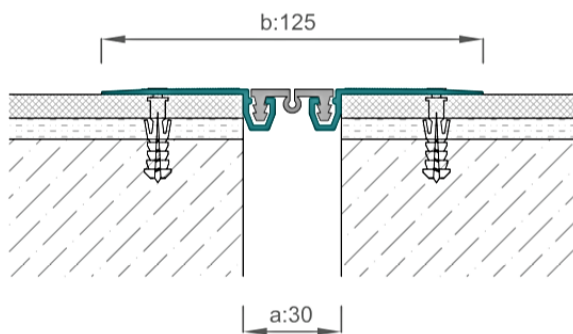

» COR 030K_152

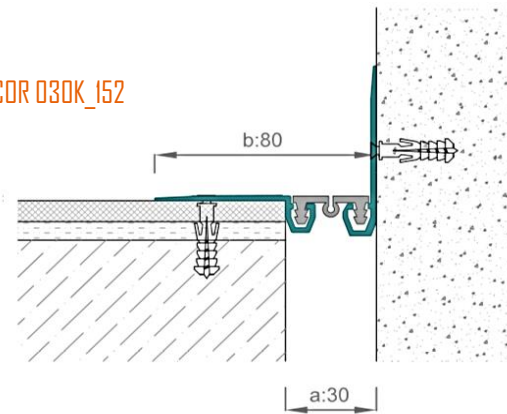

» COR 030_150

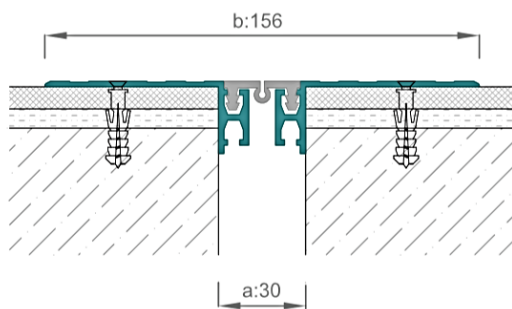

» COR 030_154

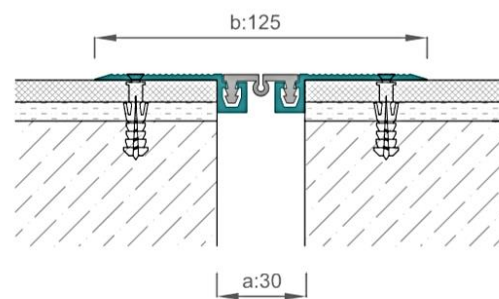

Tipo de Junta de pavimento
parede e teto
gasket type: floor, wall,
Ceiling profiles

As Junta de dilatação de acabamento são usadas para folgas de 30 mm. Montado nos dois lados do pavimento com intervalos de 35cm. Geralmente, adequado para pedestres e carga de veículos leves.

Over finish expansion joint profiles with special gasket are used for 30mm gap. Mounted to the both sides of the floor with intervals of 35cm. Generally, Suitable for pedestrians and light vehicle load.



REF	DESCRIÇÃO DESCRIPTION	LARGURA DA JUNTA (a) mm JOINT WIDTH	SUPERFÍCIE VISÍVEL (b) mm SURFACE VISIBLE	ALTURA (h) mm PROFILE HEIGHT	LARGURA (s) mm TOTAL WIDTH	SUPERFÍCIE SURFACE	CAPACIDADE MOVIMENTO MOVEMENT CAPACITY	CAPACIDADE CARGA LOAD CAPACITY
COR_030_150	Orifícios de parafuso anodizados, decorativos e largos Anodised screw holes, decorative and wide	30	156	24	156	Alumínio anod. + TPE Aluminium anod.+ TPE	± 10	Leve light
COR_030_152	Orifícios de parafuso anodizados, decorativos e estreitos Anodised screw holes, decorative and narrow	30	125	12	125	Alumínio anod. + TPE Aluminium anod.+ TPE	± 10	Light
COR_030_154	Junta de dilatação não anodizado Not anodised floor profile	30	125	12	125	Acabamento Alu + TPE Mill finish ALU + TPE	± 10	Light

**CORES DA JUNTA /
GASKET COLOURS**

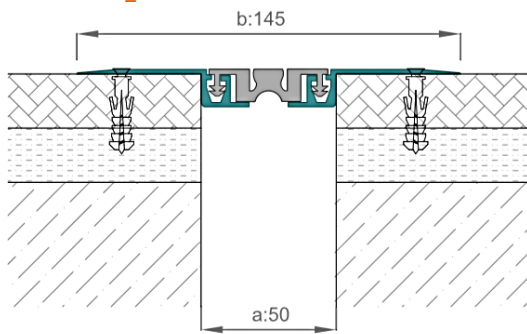
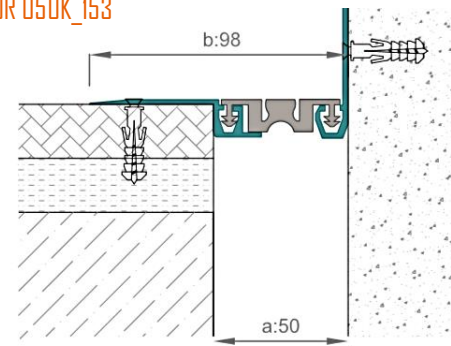
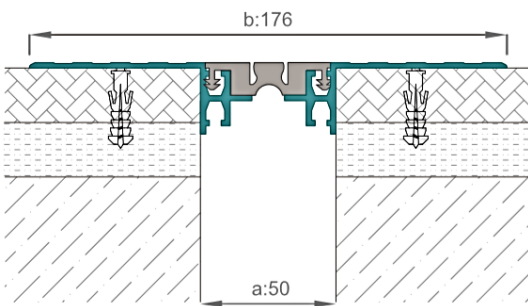
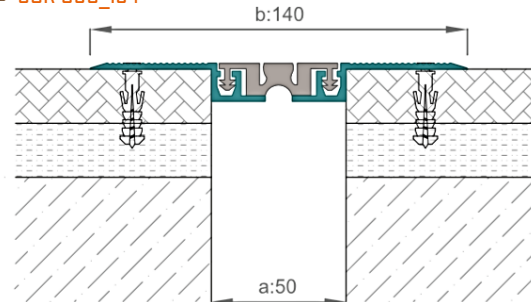
» COR_050_153

» COR_050K_153

» COR_050_151

» COR_050_154

 Tipo de junta de pavimento
 parede e teto
 gasket type: floor, wall,
 Ceiling profiles

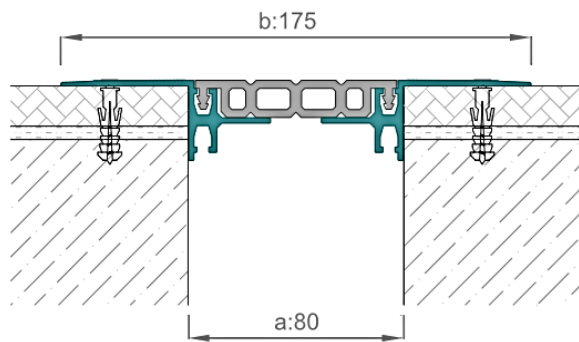
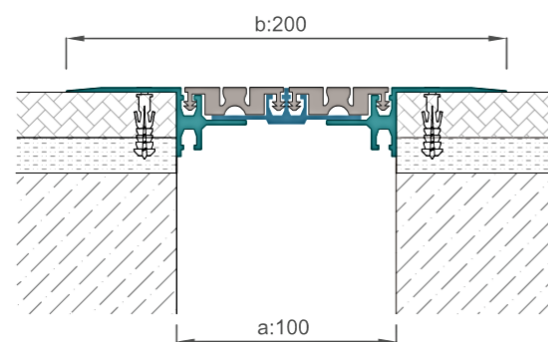
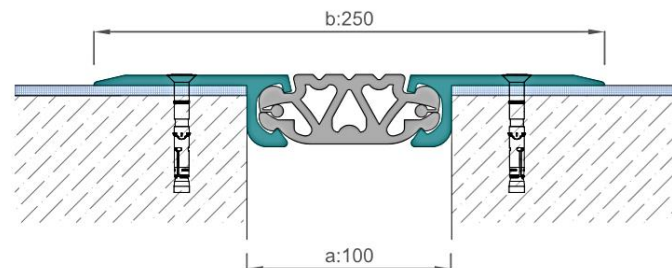
As Juntas de dilatação de acabamento são usadas para folgas de 50 mm. Geralmente, é adequado para pedestres e carga de veículos leves.

Over finish expansion joint profiles with special gaskets are used for 50mm gap. Generally, suitable for pedestrians and light vehicle load.

REF	DESCRIÇÃO DESCRIPTION	LARGURA DA JUNTA (a) mm JOINT WIDTH	SUPERFÍCIE VISÍVEL (b) mm SURFACE VISIBLE	ALTURA (h) mm PROFILE HEIGHT	LARGURA (s) mm TOTAL WIDTH	SUPERFÍCIE SURFACE	CAPACIDADE MOVIMENTO MOVEMENT CAPACITY	CAPACIDADE CARGA LOAD CAPACITY
COR_050_151	Superfície anodizada e larga Anodised and wide top surfaced.	50	176	24	176	Alumínio anod. + TPE Aluminium anod. + TPE	± 10	Leve light
COR_051_151	Superfície larga anodizada (económica) Anodised and wide top surfaced (economic)	50	176	12	176	Alumínio anod. + TPE Aluminium anod. + TPE	± 10	
COR_050_153	Anodizado, decorativo e furado Anodised, decorative and screw holed.	50	145	12	145	Alumínio anod. + TPE Aluminium anod. + TPE	± 10	
COR_050_154	Granito não anodizado. Not anodised floor profile.	50	140	12	140	Acabamento Alu + TPE Mill finish ALU + TPE	± 15	

**CORES DA JUNTA /
GASKET COLOURS**

» COR 080_153

» COR 100_153

» COR 100_191

 Tipo de junta de pavimento
 parede e teto
 gasket type: floor, wall,
 Ceiling profiles

As junta de dilatação de acabamento final são usadas para folgas de 80 ou 100 mm. O COR 080_153 e o COR 100_153 são mais adequados para aplicações em pavimentos de cerâmica, granito e mármore. O COR 100_191 é usado para aplicações de estacionamento de mesa e montadas no chão pelos dois lados com ajuda de uma âncora apropriada.

Over finish expansion joint profiles with special gasket are used for 80mm or 100mm gap. COR 080_153 and COR 100_153 is more suitable on applications for ceramic, granite and marble floor covers. COR 100_191 is used for Car park applications for screed mounted to the floor by both sides with a help of appropriate anchor.



REF	DESCRIÇÃO DESCRIPTION	LARGURA DA JUNTA (a) mm JOINT WIDTH	SUPERFÍCIE VISÍVEL (b) mm SURFACE VISIBLE	ALTURA (h) mm PROFILE HEIGHT	LARGURA (s) mm TOTAL WIDTH	SUPERFÍCIE SURFACE	CAPACIDADE MOVIMENTO MOVEMENT CAPACITY	CAPACIDADE CARGA LOAD CAPACITY
COR_080_153	Sobre acabamento, anodizado e furado por parafuso Over finish, anodised and screw holed	80	175	28	175	Alumínio anod. + TPE Aluminium anod.+ TPE	± 10	
COR_100_153	Sobre acabamento, anodizado e furado por parafuso Over finish, anodised and screw holed	100	200	28	200	Alumínio anod. + TPE Aluminium anod.+ TPE	± 15	
COR_100_191	Especial para parques de estacionamento. Special for car parks floor.	100	250	30	250	Acabamento Alu + borracha Mill finish ALU + rubber	± 15	30 Ton



Por que a dilatação foi criada
 Why dilatation has been created

SÉRIE COR 191/106/153/107

COR SERIES 191 / 106 / 153 / 107

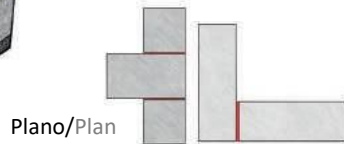
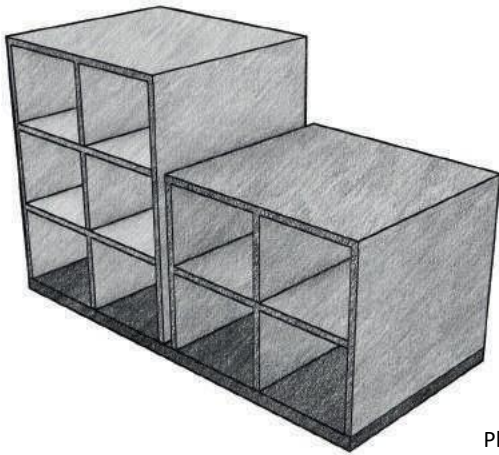

Estruturas expostas a expansões térmicas estruturas assimétricas horizontal e verticalmente
 Structures exposed to thermal expansions horizontally and vertically unsymmetrical structures

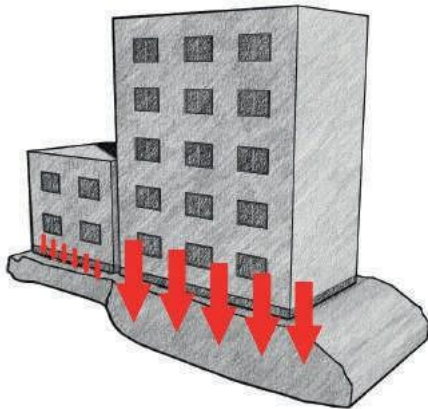

Estruturas sob diferentes tipos de piso e cargas
 Structures under different floor types and loads

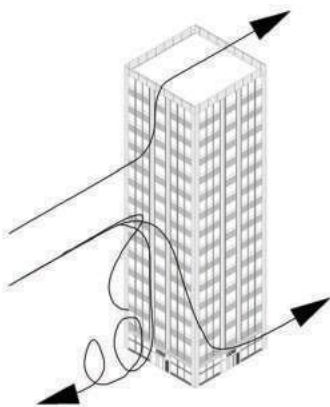

Estruturas expostas a cargas eólicas
 Structures exposed to wind loads



Movimentos de terremoto
 Earthquake Movements



**CORES DA JUNTA /
GASKET COLOURS**

PRETO
BLACK

CINZA
GREY

CREME
CREAM

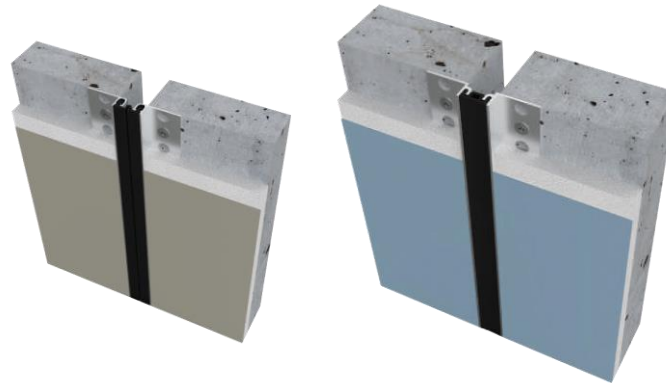

» **COR 030_200**

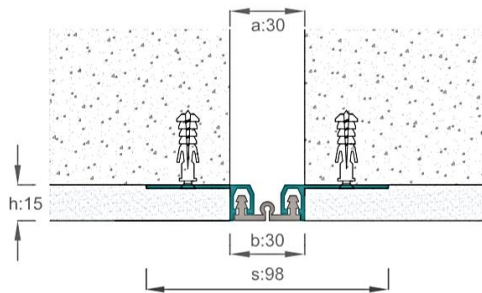

» **COR 030K_200**

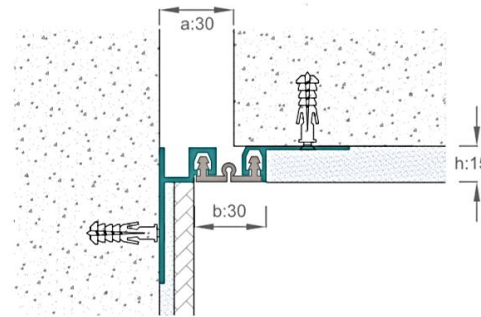

» **COR 030_221**

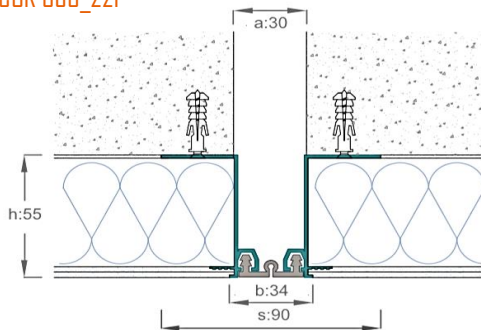

» **COR 031_220**

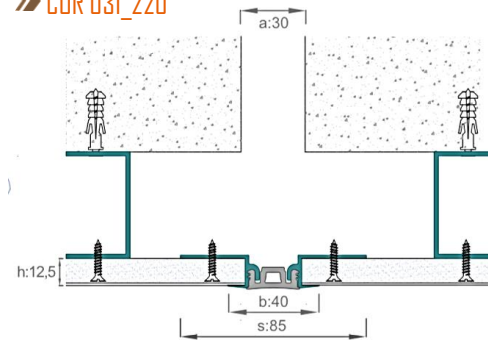

Tipo de junta de pavimento
parede e teto
gasket type floor, wall,
ceiling profiles

As junta de dilatação de parede de 30 mm são adequadas para pequenas folgas e movimentos térmicos. As junta de dilatação podem ser removidas e trocadas facilmente. Essas juntas são mais compatíveis com as juntas de pavimento. Adequado para gesso, gesso cartonado, painéis de isolamento cerâmico e térmico com pastilha de 30 mm.

30 mm wall expansion joint profiles are suitable for small gaps and thermal movements. Gaskets on the expansion joint profiles can be removed and changed easily. These profiles are more compatible with floor profiles. Suitable to plaster, dry wall, ceramic and thermal insulation boards with 30mm insert.



REF	DESCRIÇÃO DESCRIPTION	LARGURA DA JUNTA (a) mm JOINT WIDTH	SUPERFÍCIE VISÍVEL (b) mm SURFACE VISIBLE	ALTURA (h) mm PROFILE HEIGHT	LARGURA (s) mm TOTAL WIDTH	SUPERFÍCIE SURFACE	CAPACIDADE MOVIMENTO CAPACITY MOVEMENT
COR_030_200	Adequado para gesso de 12mm. Cerâmica, gesso cartonado Suitable for 12mm plaster, ceramic, drywall	30	30	15	98	Acabamento Alu + TPE Mill finish ALU + TPE	± 10
COR_031_200	Adequado para gesso de 14-18mm. Cerâmica, gesso cartonado Suitable for 14-18mm plaster, ceramic, drywall	30	30	20	100	Acabamento Alu + TPE Mill finish ALU + TPE	± 10
COR_030_220	Gesso vedado, gesso cartonado etc. Narrowed gasketed plaster, drywall etc.	30	24	12,5	90	Acabamento Alu + TPE Mill finish ALU + TPE	± 5
COR_031_220	Adequado para teto suspenso e perfis anodizados para paredes etc. Suitable to suspended ceiling and anodised profiles for drywall etc.	30	40	12,5	85	Alumínio anod. + TPE Aluminium anod. + TPE	± 5
COR_030_220	Adequado para fachada e materiais de isolamento térmico Suitable to facade and heat insulation materials	30	34	50+5	90	Acabamento Alu + TPE Mill finish ALU + TPE	± 10

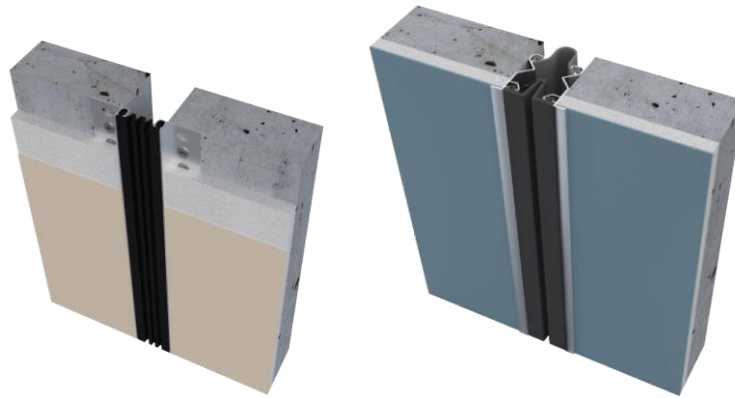

» COR 050_202

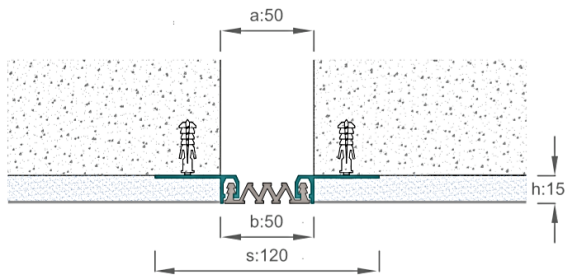

» COR 050K_202

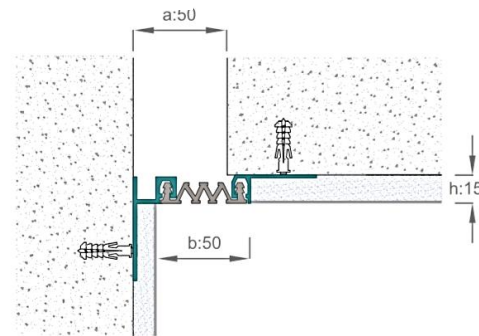

» COR 050_221

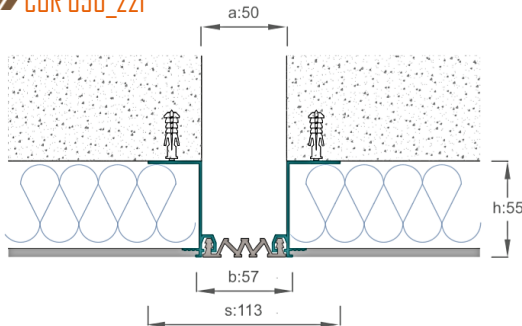

» COR 050_285

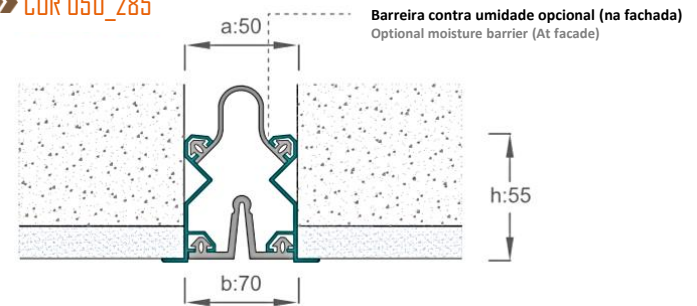

Tipo de junta de pavimento
parede e teto
gasket type: floor, wall,
Ceiling profiles

Estas junta de dilatação são adequadas para folgas de 50 mm e usados em placas de isolamento térmico de gesso, cerâmica e fs apropriadas.
These expansion joint profiles suitable for 50mm gap and used on appropriate plaster, ceramic, drywall ad thermal isolation boards.



REF	DESCRIÇÃO DESCRIPTION	LARGURA DA JUNTA (a) mm JOINT WIDTH	SUPERFÍCIE VISÍVEL (b) mm SURFACE VISIBLE	ALTURA (h) mm PROFILE HEIGHT	LARGURA (s) mm TOTAL WIDTH	SUPERFÍCIE SURFACE	CAPACIDADE MOVIMENTO CAPACITY MOVEMENT
COR_050 202	Adequado para cerâmica, gesso cartonado etc. / Vedação de parede Suitable for ceramic, drywall etc / wall gasketed	50	50	15	120	Acabamento Alu + TPE Mill finish ALU + TPE	± 20
COR_051 202	Adequado para cerâmica, gesso cartonado, etc. / Vedação de pavimento Suitable for ceramic, drywall etc. / Floor gasketed	50	50	15	120	Acabamento Alu + TPE Mill finish ALU + TPE	± 10
COR_050 203	Adequado para betonilha 14-18mm a cerâmica Suitable for 14-18mm screed and ceramic.	50	50	20	120	Acabamento Alu + TPE Mill finish ALU + TPE	± 20
COR_050 221	Adequado para isolamentos térmicos e fachadas etc. Suitable for heat insulations and facade etc..	50	57	50+5	113	Acabamento Alu + TPE Mill finish ALU + TPE	± 20
COR_050 285	Sísmica adequada para áreas internas e de fachada Suitable seismic for internal and facade areas	50	70	55	70	Acabamento Alu + TPE Mill finish ALU + TPE	± 25

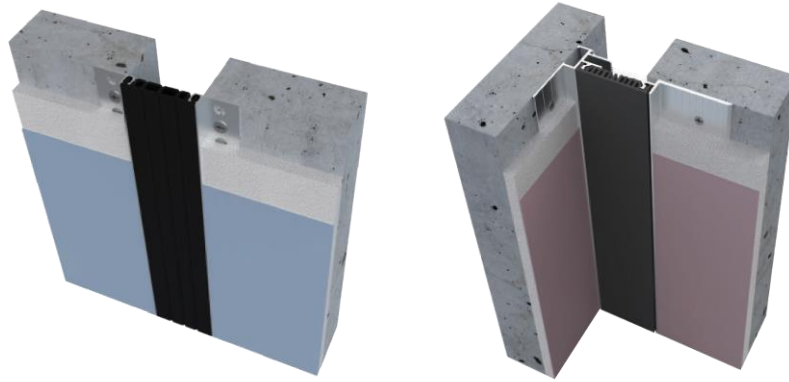

**CORES DA JUNTA /
GASKET COLOURS**



» COR 080_202

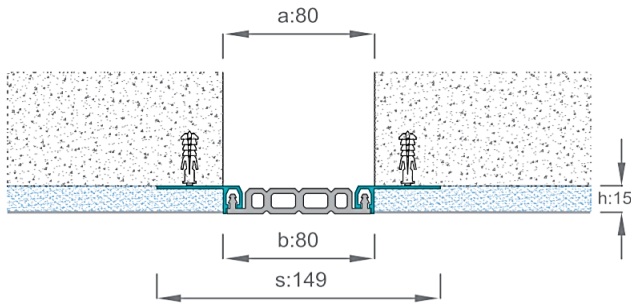

» COR 080_202

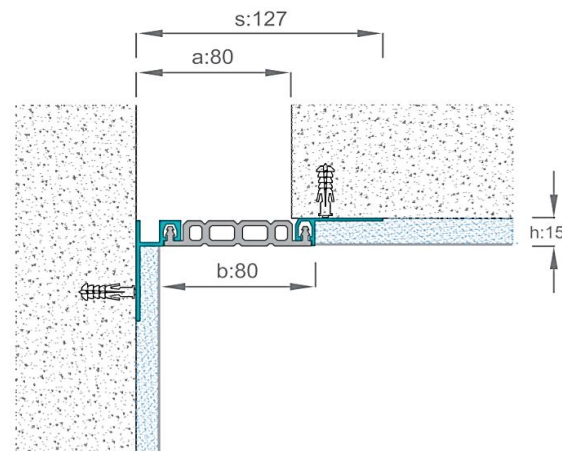

» COR 080_215

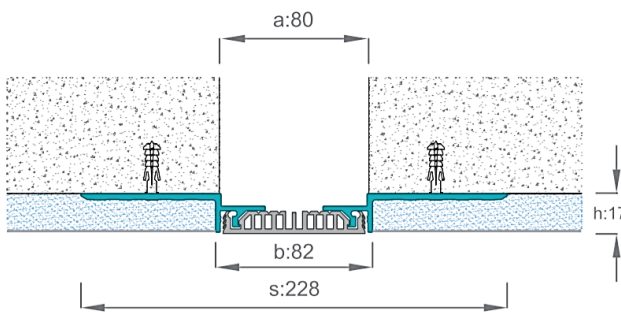

» COR 080K_215

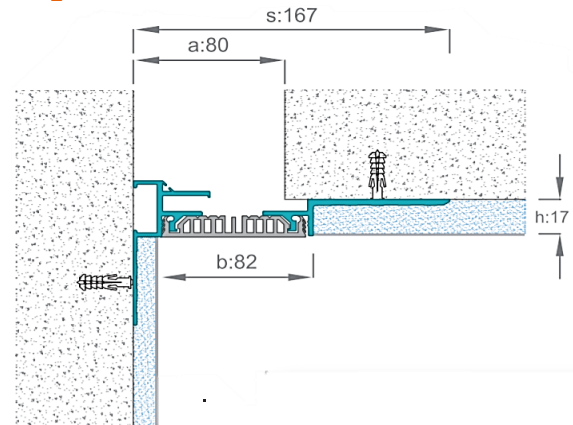

Tipo de junta de pavimento
parede e teto
gasket type floor, wall,
ceiling profiles

Adequado para coberturas de pavimento de nível semelhante com juntas intermediárias elastoméricas. Juntas de dilatação com acabamento final usados para intervalos de 80 mm. Recomendado para estruturas sujeitas a pequenos movimentos.
Suitable to similar level flooring covers with elastomeric middle gaskets. Under finish expansion joint profiles used for 80mm gaps. Recommended for structures where subject to small movements.



REF	DESCRIÇÃO DESCRIPTION	LARGURA DA JUNTA (a) mm JOINT WIDTH	SUPERFÍCIE VISÍVEL (b) mm SURFACE VISIBLE	ALTURA PERFIL (h) mm PROFILE HEIGHT	LARGURA DA TOTAL (s) mm TOTAL WIDTH	SUPERFÍCIE SURFACE	CAPACIDADE MOVIMENTO MOVEMENT CAPACITY
COR_080_202	Adequado com betonilha (COR_80 106), cerâmica etc, com detalhes de junta plana Suitable with (COR_80 106) screed, ceramic and etc, with flat gasket detail	80	80	15	149	Acabamento Alu + TPE Mill finish ALU + TPE	± 10
COR_080_215	Adequado com betonilha (COR_80 109), cerâmica etc, com detalhes de junta plana Suitable with (COR_80 106) screed, ceramic and etc, with flat gasket detail	80	82	17	228	Acabamento Alu + TPE Mill finish ALU + TPE	± 10

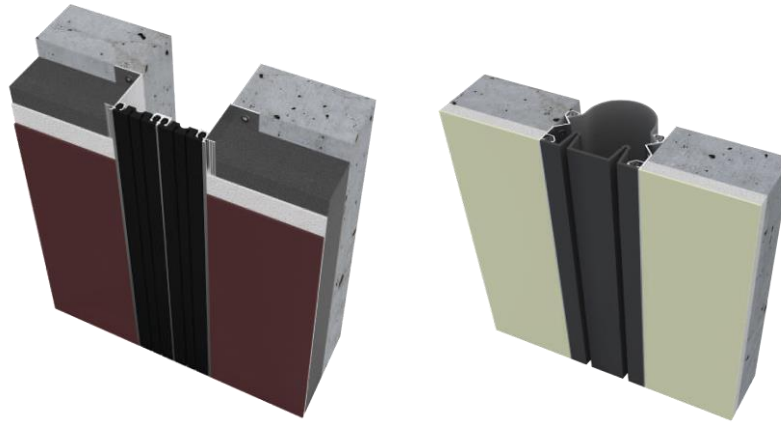

**CORES DA JUNTA /
GASKET COLOURS**



» COR 100_202

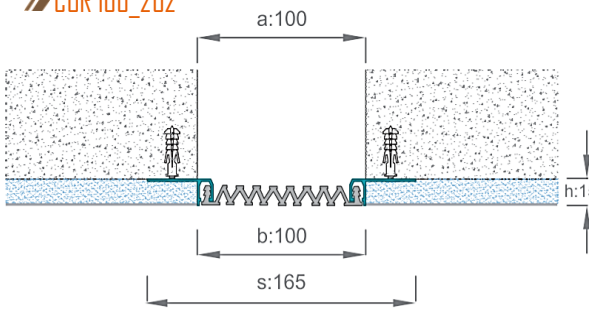

» COR 102_202

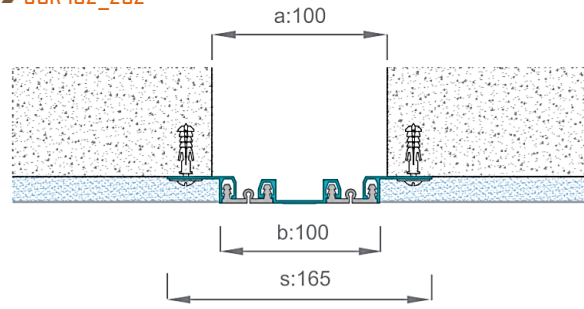

» COR 101_221

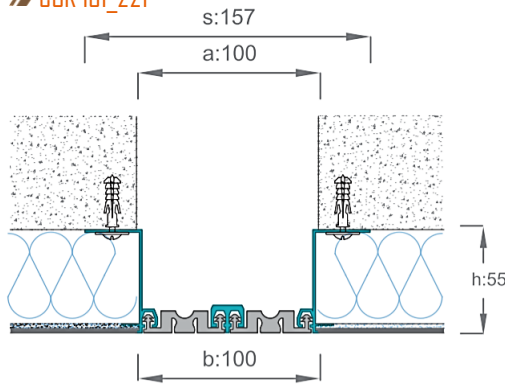

» COR 100_285

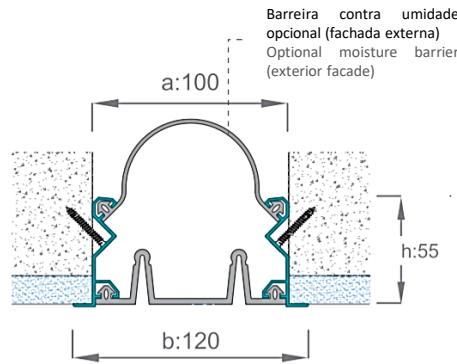

Tipo de junta de pavimento
parede e teto
gasket type: floor, wall,
ceiling profiles



Juntas de dilatação adequadas para folgas de 100 mm com seleções alternativas de juntas. Utilizado em placas apropriadas de gesso, cerâmica, parede seca sujeita e isolamento térmico.
Expansion joints profiles suitable for 100mm gap with alternative gasket selections. Used on appropriate plaster, ceramic, subjected dry wall and thermal isolation boards.

REF	DESCRIÇÃO DESCRIPTION	LARGURA DA JUNTA (a) mm JOINT WIDTH	SUPERFÍCIE VISÍVEL (b) mm SURFACE VISIBLE	ALTURA PERFIL (h) mm PROFILE HEIGHT	LARGURA DA TOTAL (s) mm TOTAL WIDTH	SUPERFÍCIE SURFACE	CAPACIDADE MOVIMENTO MOVEMENT CAPACITY
COR_100_202	Adequado para betoniha, cerâmica, gesso cartonado e etc Suitable for screed, ceramic, dry wall and etc	100	100	15	165	Acabamento Alu + TPE Mill finish ALU + TPE	± 50
COR_101_202	Adequado para betoniha, cerâmica, gesso cartonado etc. (vedada pelo piso) Suitable for screed, ceramic, dry wall and etc. (floor gasketed)	100	100	15	165	Acabamento Alu + TPE Mill finish ALU + TPE	± 16
COR_102_202	Adequado para betoniha, cerâmica, gesso cartonado etc. (junta decorativa e estreita) Suitable for screed, ceramic, dry wall and etc. (decorative and narrowed gasket).	100	100	15	165	Alu anodizado + TPE Anodised ALU + TPE	± 14
COR_100_203	Adequado para betoniha, cerâmica, gesso cartonado etc. (14-18mm) Suitable for screed, ceramic, dry wall and etc. (14-18mm)	100	100	20	165	Acabamento Alu + TPE Mill finish ALU + TPE	± 50
COR_100_221	Adequado para fachada com sua característica externa. Suitable for facade with its externally proofed feature	100	100	50+5	157	Acabamento Alu + TPE Mill finish ALU + TPE	± 50
COR_101_221	Adequado para isolamentos térmicos de fachadas etc. (vedado pelo piso) Suitable for heat insulations and facade and etc. (floor gasketed)	100	100	50+5	157	Acabamento Alu + TPE Mill finish ALU + TPE	± 16
COR_102_221	Adequado para isolamentos térmicos de fachadas etc. (vedação plana) Suitable for heat insulations and facade and etc. (flat gasketed)	100	100	50+5	157	Acabamento Alu + TPE Mill finish ALU + TPE	± 16
COR_100_285	Adequado a áreas internas e fachada. (sísmicas) Suitable with internal areas and facade. (seismic)	100	120	55	120	Acabamento Alu + TPE Mill finish ALU + TPE	± 75

Juntas de parede e teto montados na superfície
Surface mounted wall and ceiling profiles

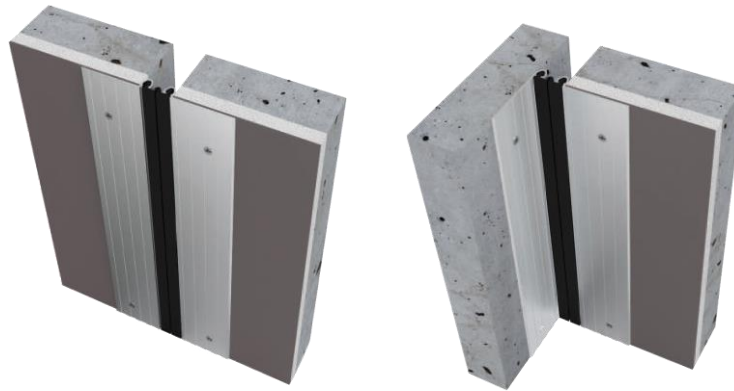

CORES DA JUNTA /
GASKET COLOURS



» COR 030_251

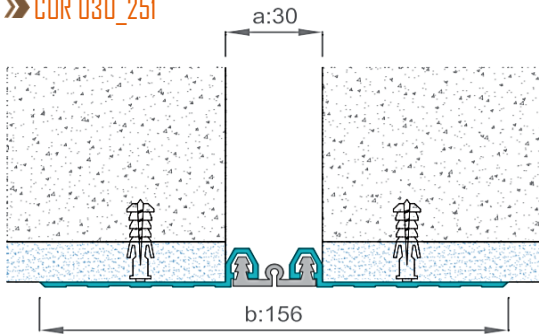

» COR 030_253

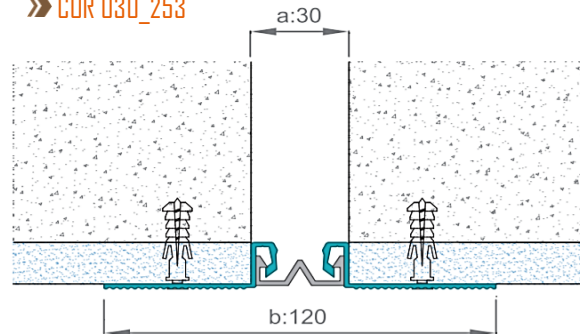

» COR 030_262

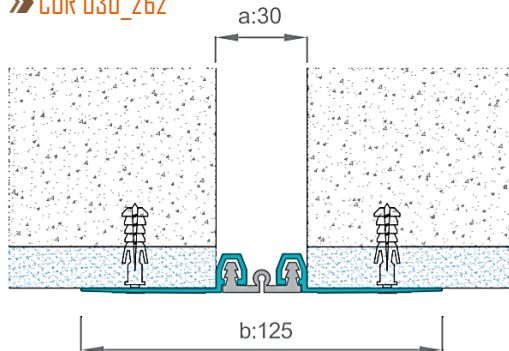

» COR 030K_262

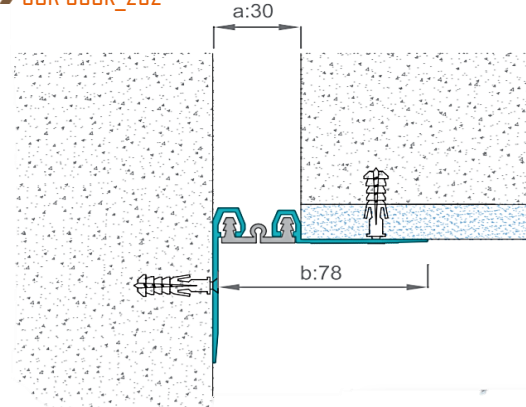

Tipo de junta de pavimento
parede e teto
gasket type: floor, wall,
Ceiling profiles

As juntas de dilatação de acabamento excessivo são adequados para intervalos de 30 mm. Recomendado para estruturas onde é submetido a fatores térmicos e pequenos movimentos. Cada design tem a opção de junta de canto. As juntas são fornecidas em 25 metros.

Over finish expansion joint profiles are suitable for 30mm gap. Recommended for structures where subjected to thermal factors and small movements. Each design has corner profile option. Profiles are delivered by 3 meters and gaskets 25 meters.

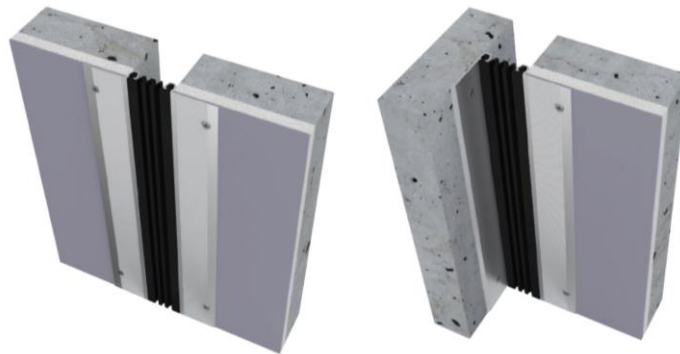

REF	DESCRIÇÃO DESCRIPTION	LARGURA DA JUNTA (a) mm JOINT WIDTH	SUPERFÍCIE VISÍVEL (b) mm SURFACE VISIBLE	ALTURA PERFIL (h) mm PROFILE HEIGHT	LARGURA DA TOTAL (s) mm TOTAL WIDTH	SUPERFÍCIE SURFACE	CAPACIDADE MOVIMENTO MOVEMENT CAPACITY
COR_30_251	Superfície superior larga anodizada Anodised wide top surface	30	156	12	156	Alu anodizado + TPE Anodised ALU + TPE	± 10
COR_30_253	Perfil de parede com acabamento laminado Mill finish wall-ceiling profile	30	120	14	120	Acabamento Alu + TPE Mill finish ALU + TPE	± 10
COR_030_255	Acabamento amplo superfície superior Mill finish wide top surface.	30	180	14	180	Acabamento Alu + TPE Mill finish ALU + TPE	± 10
COR_030_260	Anodizado, orifícios para parafusos, decorativos Anodised, screw holes, decorative	30	125	12	125	Alu anodizado + TPE Anodised ALU + TPE	± 10
COR_030_262	Anodizado, furos para parafusos, decorativo, económico. Anodised, screw holes, decorative, economic	30	125	12	125	Alu anodizado + TPE Anodised ALU + TPE	± 10

Juntas de parede e teto montados na superfície
 Surface mounted wall and ceiling profiles

**CORES DA JUNTA /
GASKET COLOURS**

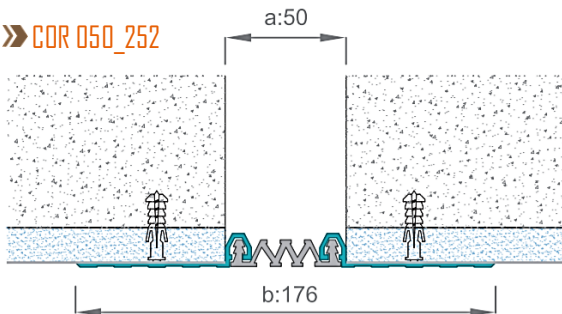

» COR_050_252

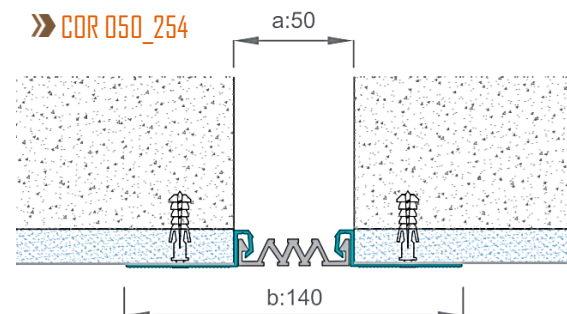

» COR_050_254

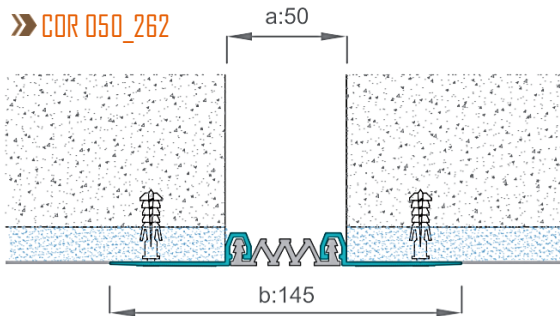

» COR_050_262

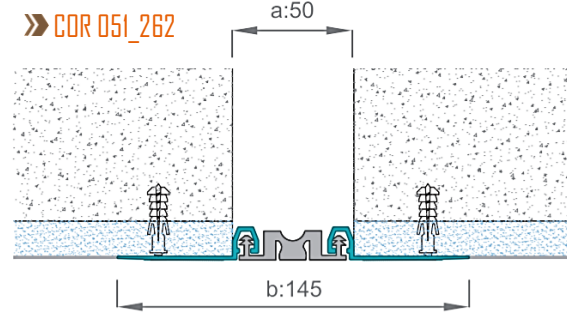

» COR_051_262

 Tipo de junta de pavimento
 parede e teto
 gasket type: floor, wall,
 Ceiling profiles

As juntas de dilatação montadas na superfície são adequados para folgas de 50 mm. Opções de juntas: polido e anodizado estão disponíveis. Os furos são feitos como parte da produção. Pode ser facilmente montado e compatível com as juntas de pavimento.

Surface mounted expansion joint profiles are suitable for 50mm gap. Mat anodized and polished profile options are available. Screw holes are made as part of the production. Can be easily assembled and compatible to floor profiles.



REF	DESCRIÇÃO DESCRIPTION	LARGURA DA JUNTA (a) mm JOINT WIDTH	SUPERFÍCIE VISÍVEL (b) mm SURFACE VISIBLE	ALTURA PERFIL (h) mm PROFILE HEIGHT	LARGURA DA TOTAL (s) mm TOTAL WIDTH	SUPERFÍCIE SURFACE	CAPACIDADE MOVIMENTO MOVEMENT CAPACITY
COR_050_252	Superfície superior larga anodizada Anodised wide top surface	50	176	12	176	Alu anodizado + TPE Anodised ALU + TPE	± 20
COR_051_252	Superfície superior larga anodizada (vedada pelo pavimento) Anodised wide top surface (floor gasketed)	50	176	12	176	Alu anodizado + TPE Anodised ALU + TPE	± 10
COR_050_254	Junta de parede com acabamento laminado Mill finish wall-ceiling profile	50	140	14	140	Acabamento Alu + TPE Mill finish ALU + TPE	± 20
COR_050_255	Superfície superior larga do acabamento do moinho Mill finish wide top surface	50	200	14	200	Acabamento Alu + TPE Mill finish ALU + TPE	± 20
COR_050_261	Anodizado, furado por parafuso, decorativo. Anodised, screw holed, decorative	50	145	12	145	Alu anodizado + TPE Anodised ALU + TPE	± 20
COR_050_262	Anodizado, furado por parafuso, decorativo, econômico Anodised, screw holed, decorative, economic	50	145	12	145	Alu anodizado + TPE Anodised ALU + TPE	± 20
COR_051_262	Anodizado, furo roscado / pavimento vedado Anodised, screw hole/floor gasketed	50	145	12	145	Alu anodizado + TPE Anodised ALU + TPE	± 10

Juntas de parede e teto montados na superfície
Surface mounted wall and ceiling profiles

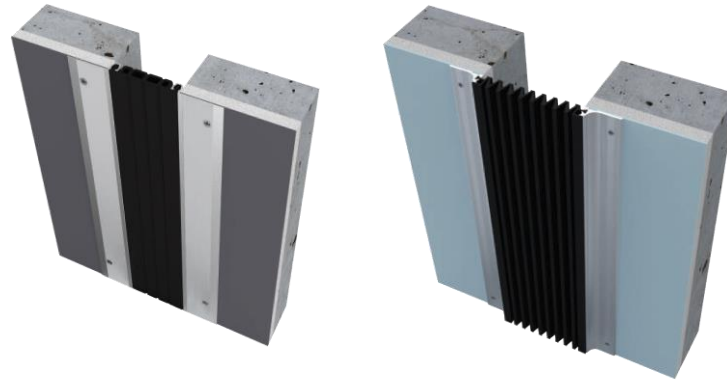

CORES DA JUNTA /
GASKET COLOURS



» COR 080_262

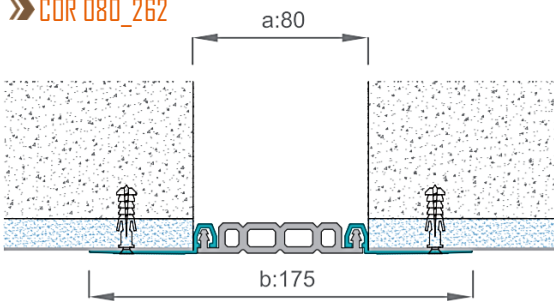

» COR 100_262

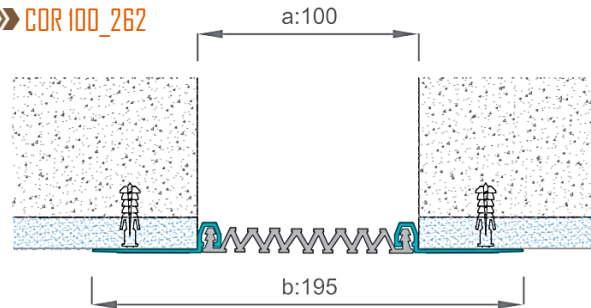

» COR 100_252

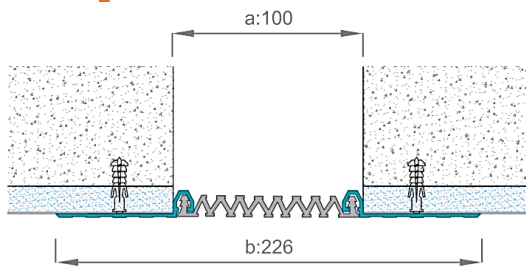

» COR 100_295

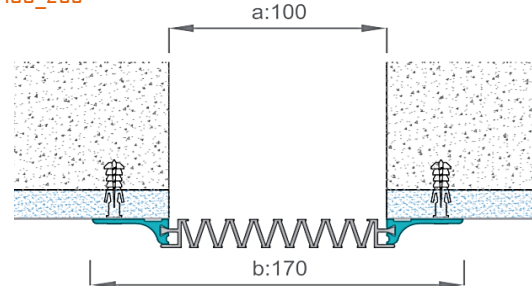

Tipo de junta de pavimento
parede e teto
gasket type: floor, wall,
Ceiling profiles

As junta de dilatação de parede e teto montadas na superfície são adequados para folgas de 80 a 100 mm com opções alternativas de juntas. Usada para tetos a sua alta capacidade de movimento pode ser uma alternativa aos perfis sísmicos.

Surface mounted wall-ceiling expansion joint profiles are suitable for 80-100mm gap with alternative gasket options. Used for ceilings and its high movement capacity can be an alternative to seismic profiles.



REF	DESCRIÇÃO DESCRIPTION	LARGURA DA JUNTA (a) mm JOINT WIDTH	SUPERFÍCIE VISÍVEL (b) mm SURFACE VISIBLE	ALTURA PERFIL (h) mm PROFILE HEIGHT	LARGURA DA TOTAL (s) mm TOTAL WIDTH	SUPERFÍCIE SURFACE	CAPACIDADE MOVIMENTO MOVEMENT CAPACITY
COR_080_262	Anodizado, furado por parafuso, decorativo, econômico Anodised, screw holed, decorative, economic	80	175	12	175	Alu anodizado + TPE Anodised ALU + TPE	± 10
COR_100_252	Superfície superior larga anodizada Anodised wide top surface	100	226	12	226	Alu anodizado + TPE Anodised ALU + TPE	± 50
COR_100_254	Junta de parede - acabamento de revestimento Mill Finish wall-ceiling profile	100	188	14	188	Acabamento Alu + TPE Mill finish ALU + TPE	± 50
COR_100_255	Acabamento amplo superfície superior Mill finish wide top surface	100	250	14	250	Acabamento Alu + TPE Mill finish ALU + TPE	± 50
COR_100_261	Anodizado, furado por parafuso, decorativo Anodised, screw holed, decorative	100	195	12	195	Alu anodizado + TPE Anodised ALU + TPE	± 50
COR_100_262	Anodizado, furado por parafuso, decorativo, econômico Anodised, screw holed, decorative, economic	100	195	12	195	Alu anodizado + TPE Anodised ALU + TPE	± 50
COR_101_262	Adequado para isolamentos térmicos de fachadas etc. (vedação plana) Suitable for heat insulations and facade and etc. (flat gasketed)	100	195	12	195	Alu anodizado + TPE Anodised ALU + TPE	± 16
COR_102_262	Adequado a áreas internas e fachada. (sísmicas) Suitable with internal areas and facade. (seismic)	100	190	12	190	Alu anodizado + TPE Anodised ALU + TPE	± 14
COR_100_295	Adequado para betonilha, cerâmica, gesso cartonado e etc Suitable for screed, ceramic, dry wall and etc	100	170	14	170	Acabamento Alu + TPE Mill finish ALU + TPE	± 100/-60

Juntas de parede e teto montados na superfície
Surface mounted wall and ceiling profiles

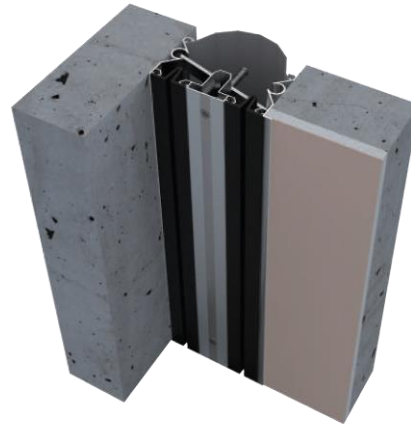

CORES DA JUNTA /
GASKET COLOURS



» COR 150_285

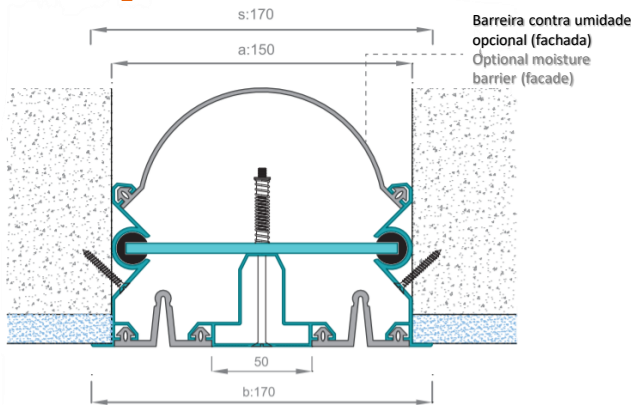

» COR 150K_285

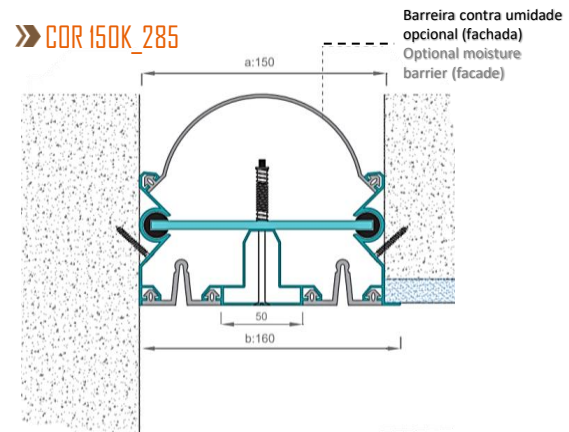

» COR 200_285

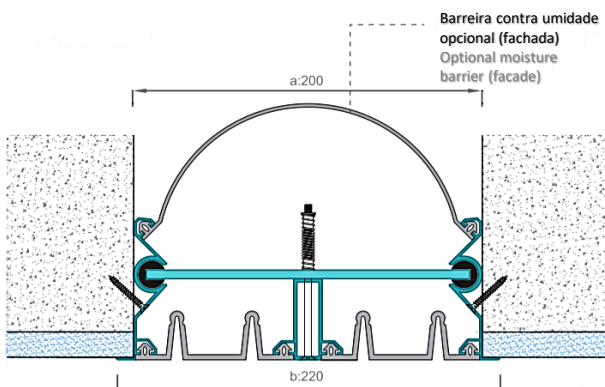

» COR 150_295

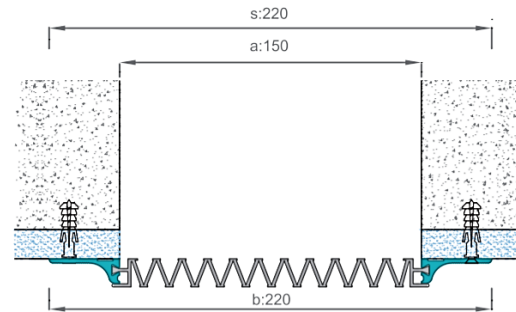

Tipo de junta de pavimento
parede e teto
gasket type: floor, wall,
ceiling profiles

As juntas de dilatação com acabamento inferior e superior, são utilizados para folgas maiores (150-200-250 mm). Decorativo e adequado para movimentos elevados. Também pode ser usado na fachada das estruturas.

Under and over finish expansion joint profiles are suitable for larger gaps (150-200-250mm). Decorative and suitable for high movements. Can also be used at facade of the structures.



REF	DESCRIÇÃO DESCRIPTION	LARGURA DA JUNTA (a) mm JOINT WIDTH	SUPERFÍCIE VISÍVEL (b) mm SURFACE VISIBLE	ALTURA PERFIL (h) mm PROFILE HEIGHT	LARGURA DA TOTAL (s) mm TOTAL WIDTH	SUPERFÍCIE SURFACE	CAPACIDADE MOVIMENTO MOVEMENT CAPACITY
COR_150_285	Adequado para áreas internas ou externas (sísmica) Suitable for internal or external areas (seismic)	150	170	130	170	Acabamento Alu + TPE Mill finish ALU + TPE	± 75
COR_150_295	Acabamento de fresagem, orifícios para parafusos, acordeão vedado Mill finish, screw holes, accordion gasketed	150	220	14	220	Acabamento Alu + TPE Mill finish ALU + TPE	± 130/-90
COR_200_285	Adequado para áreas internas ou externas (sísmica) Suitable for internal or external areas (seismic)	200	220	130	220	Acabamento Alu + TPE Mill finish ALU + TPE	± 100
COR_200_295	Acabamento de fresagem, orifícios para parafusos, acordeão vedado Mill finish, screw holes, accordion gasketed	200	270	14	270	Acabamento Alu + TPE Mill finish ALU + TPE	± 200/-130



» COR 500_01

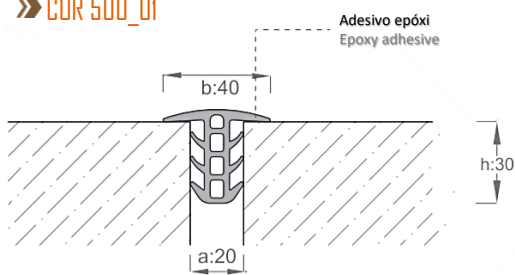

» COR 500_01

APLICAÇÃO DE CANTO / CORNER APPLICATION

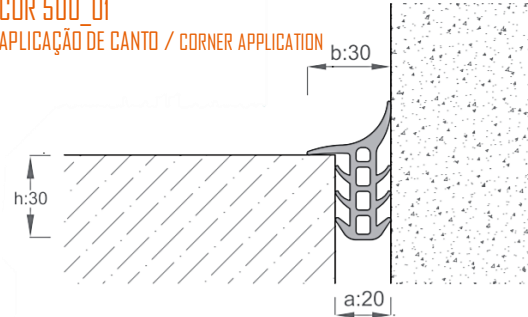

» COR 500_01 A

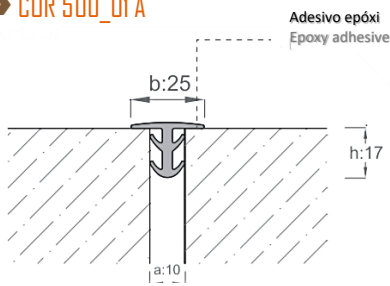

» COR 500_02

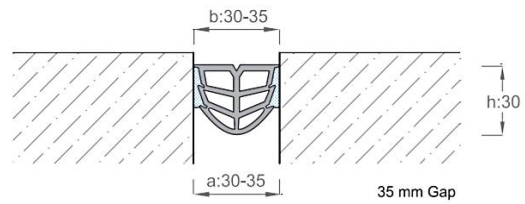

» COR 500_01 B

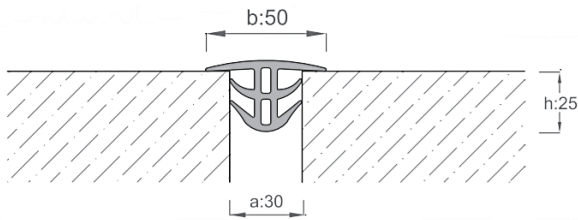

» COR 500_02A

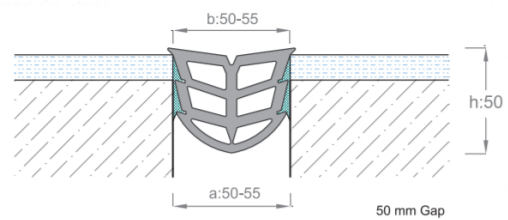

» COR 500_01 C

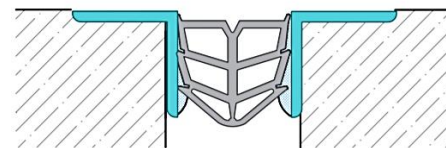
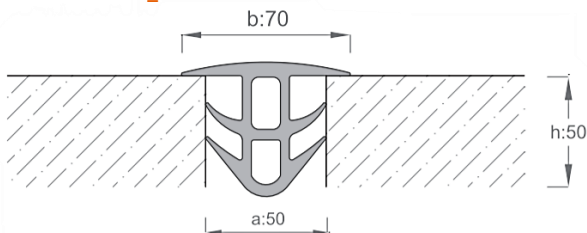

Tipo de junta de pavimento
parede e teto
gasket type: floor, wall,
Ceiling profiles

Perfis TPE, TPV (opcionais) feitos a partir do zero e adequados para elementos pré-moldados, fachada, aplicações de paredes secas e aplicações de laminados compactados. Fácil e prático na montagem.

TPE, TPV (optional) profiles made from scratch and suitable for precast elements, facade, drywall applications and compacted laminate applications. Easy and practical on assembly.





» COR 500_05

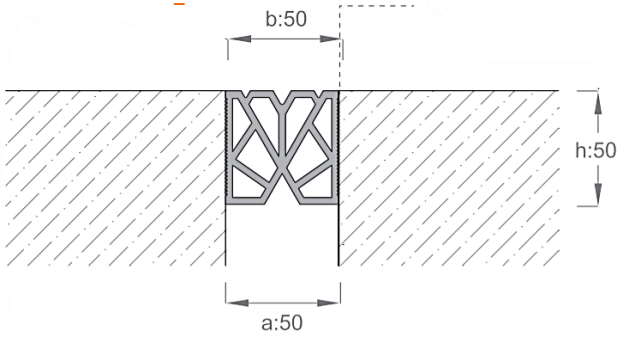

» COR 500_05

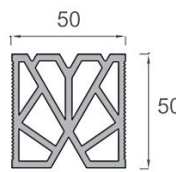

» COR 500_06

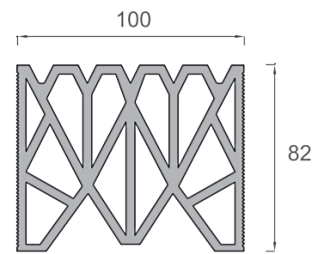

» COR 500_07

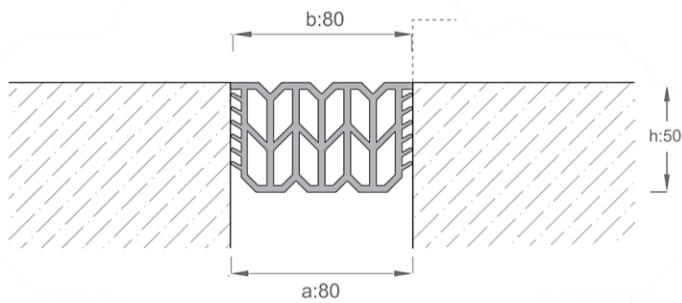

» COR 500_03

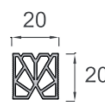

» COR 500_04

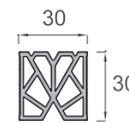

» COR 500_51

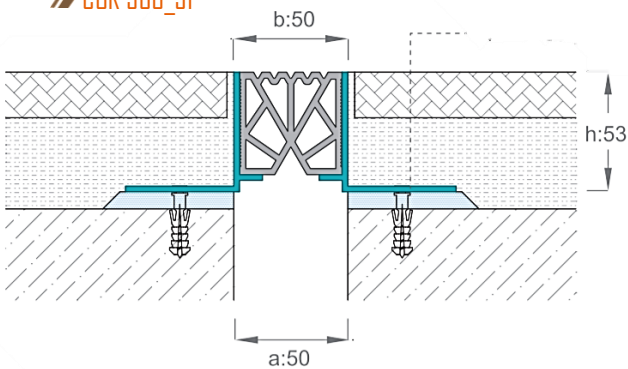

» COR 193_050

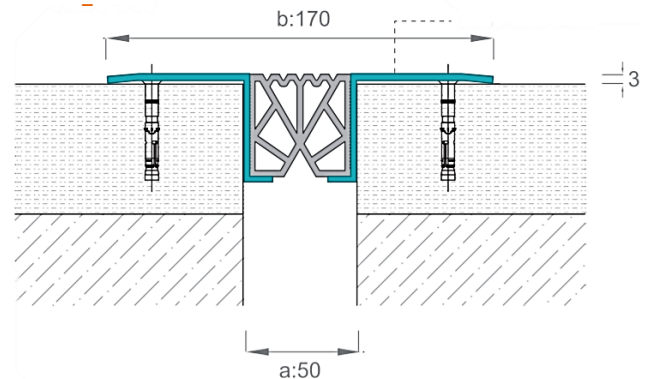

Tipo de Junta de pavimento
 parede e teto
 gasket type: floor, wall,
 Ceiling profiles

Os produtos feitos de material elastômero termoplástico são adequados para intervalos de 30, 50, 100mm e utilizados em pavimentos, paredes e tetos.

Products made from thermoplastic elastomer material are suitable for 30, 50, 100mm gaps and used in floors, walls and ceilings.

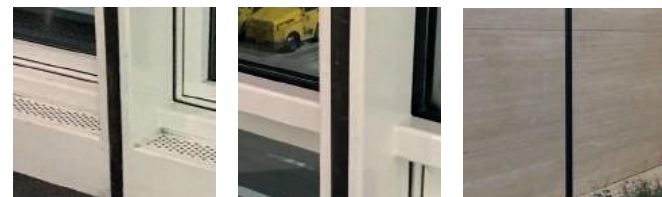

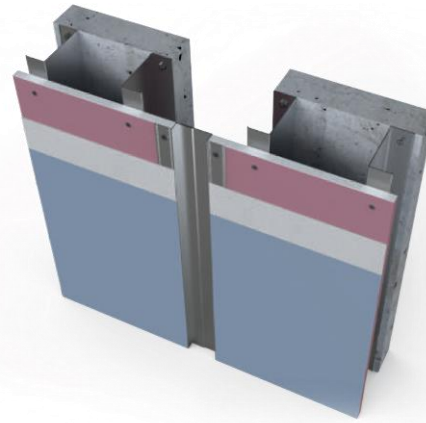
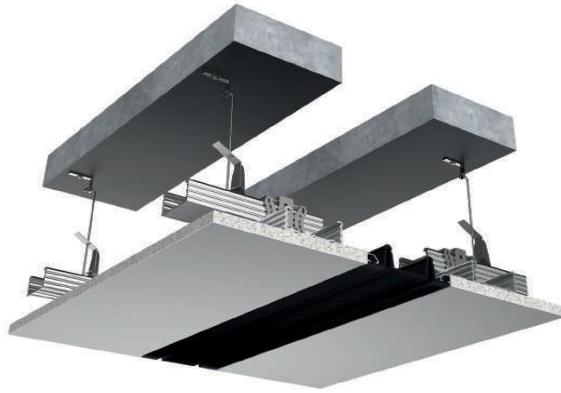
**CORES DA JUNTA /
GASKET COLOURS**

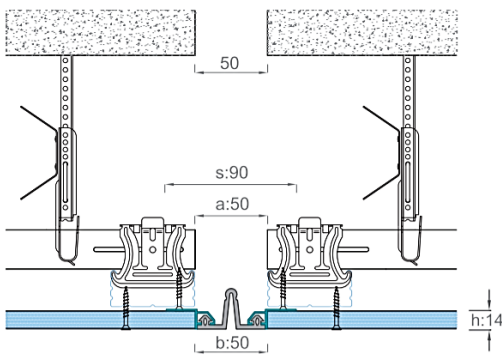
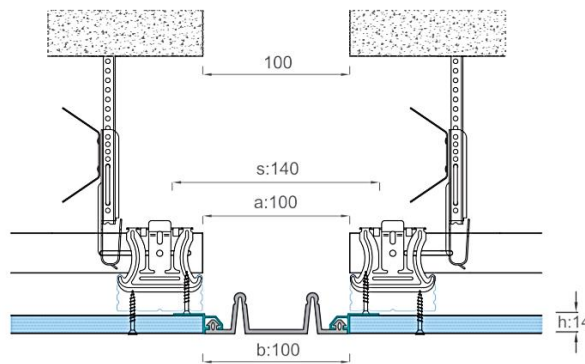
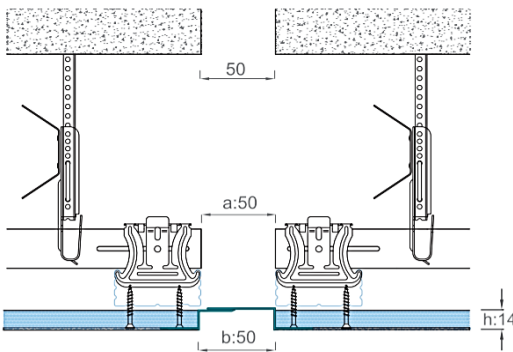
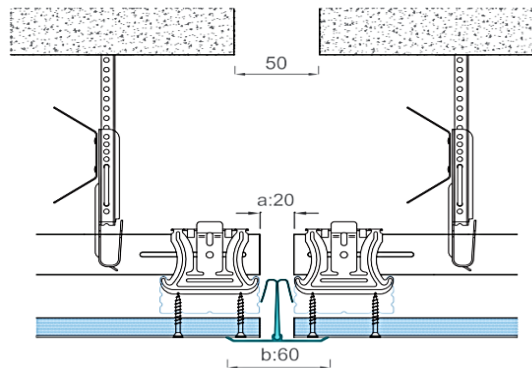
» COR 287_050

» COR 287_100

» COR F50

» COR 60DT

 Tipo de junta de pavimento
parede e teto
gasket type: floor, wall,
Ceiling profiles

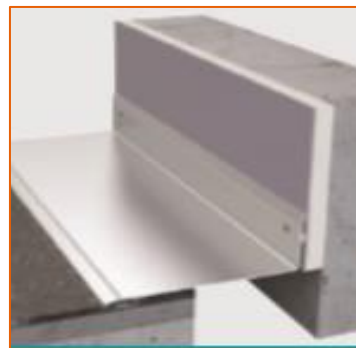
Junta de dilatação de teto suspenso usados para vários tipos de teto suspenso. Elas são decorativas e vêm com juntas ou perfis totalmente em alumínio.

Suspended ceiling expansion joint profiles used for various types of suspended ceilings. They are decorative and come with gasket or fully aluminum profiles.



REF	DESCRIÇÃO DESCRIPTION	LARGURA DA JUNTA (a) mm JOINT WIDTH	SUPERFÍCIE VISÍVEL (b) mm SURFACE VISIBLE	ALTURA PERFIL (h) mm PROFILE HEIGHT	LARGURA DA TOTAL (s) mm TOTAL WIDTH	SUPERFÍCIE SURFACE	CAPACIDADE MOVIMENTO MOVEMENT CAPACITY
COR_050 287	Adequado para áreas internas ou externas (sísmica) Suitable for internal or external areas (seismic)	50	50	14	90	Acabamento Alu + TPE Mill finish ALU + TPE	± 25
COR_100 287	Acabamento de fresagem, orifícios para parafusos, acordeão vedado Mill finish, screw holes, accordion gasketed	100	100	14	140	Acabamento Alu + TPE Mill finish ALU + TPE	± 75
COR_ARF 50	Adequado para áreas internas ou externas (sísmica) Suitable for internal or external areas (seismic)	50	50	14	100	Alumínio anodizado Anodised ALU	± 15
COR_AR 60DT	Acabamento de fresagem, orifícios para parafusos, acordeão vedado Mill finish, screw holes, accordion gasketed	20	60	-	60	Alumínio anodizado Anodised ALU	± 15



Juntas de pavimento, parede, teto, cobertura
Floor, wall, ceiling, cover profiles



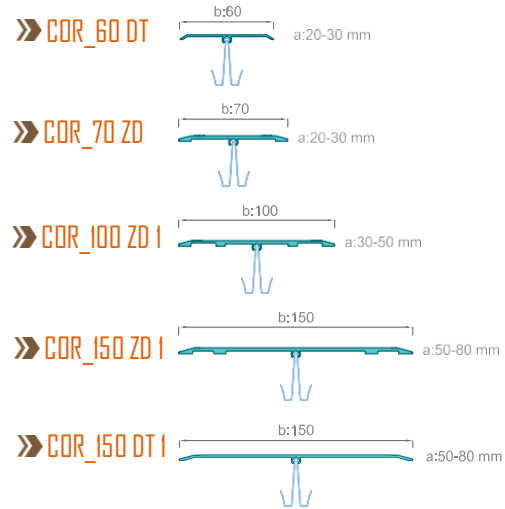
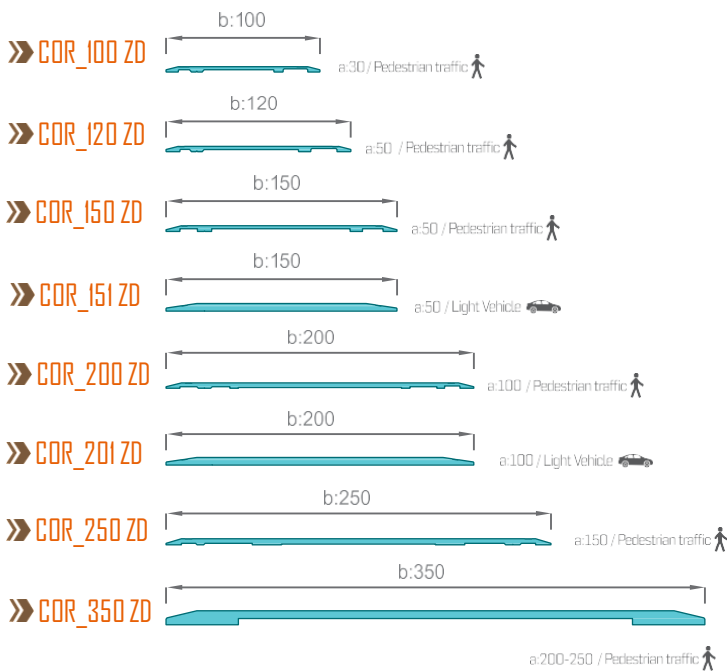
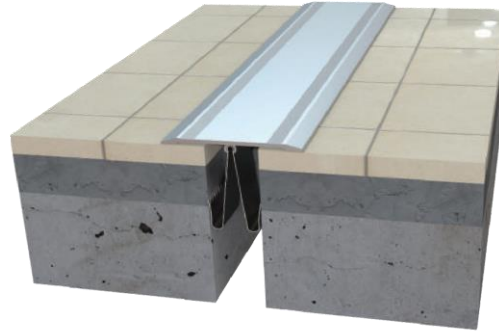

Tipo de junta de pavimento
 parede e teto
 gasket type floor, wall,
 Ceiling profiles

Pode ser aplicado com o sistema de cliques (sem a necessidade de parafusos) em intervalos dimensionados padrão.

Can be applied with clips system (without needing screws) to standard dimensioned gaps.

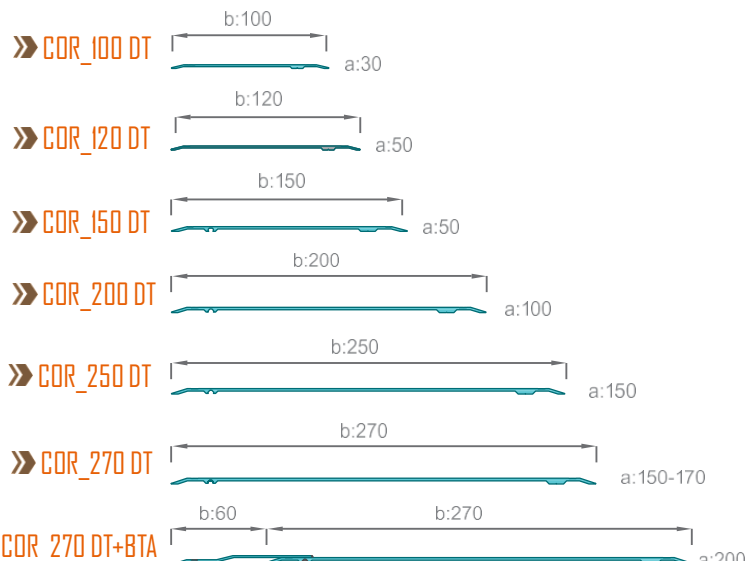

Prático na montagem com um orifício lateral. Juntas de cobertura anodizadas podem ser facilmente aplicadas em pavimentos, paredes e tetos.

Practical on assembly with one side screw hole. Anodized cover profiles can easily be applied to floors, walls and ceilings.

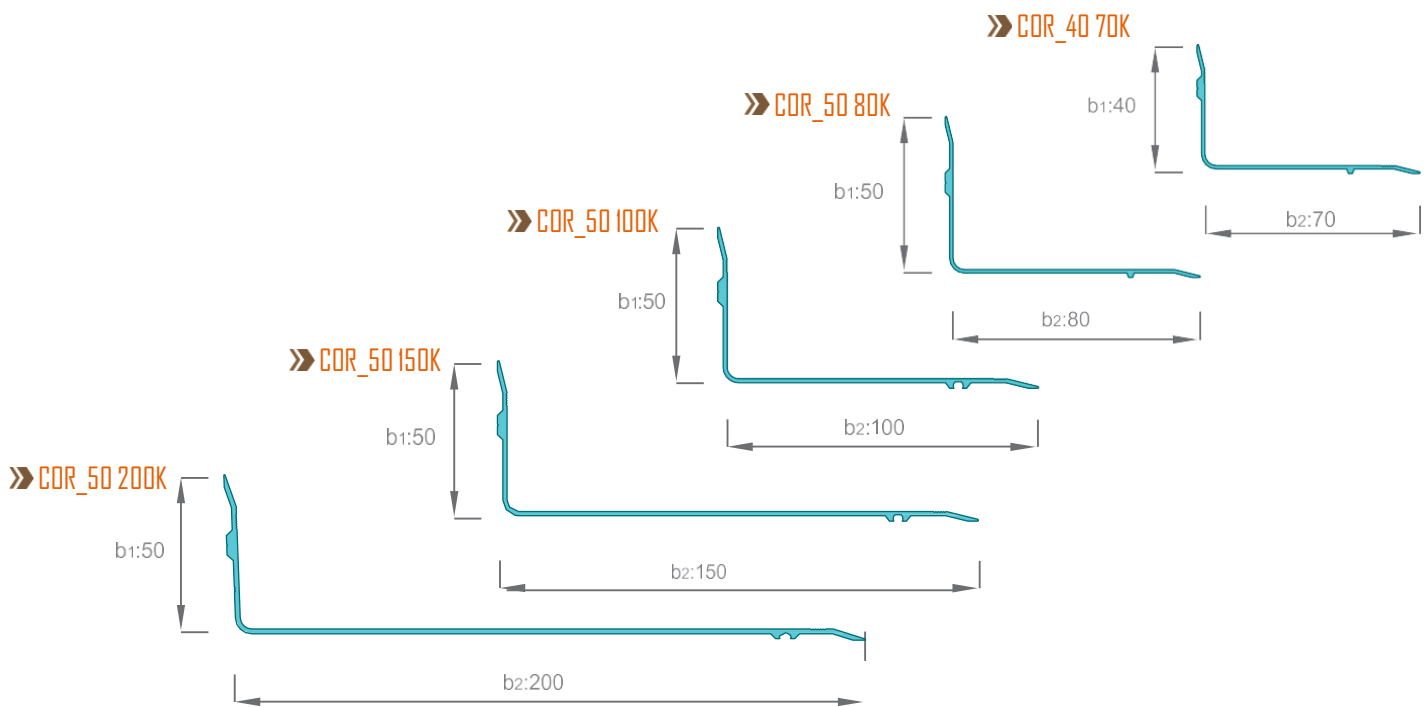
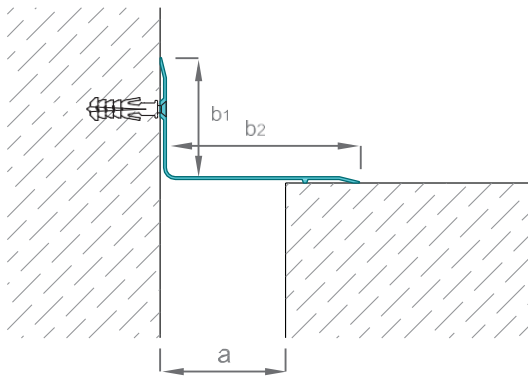

Tipo de junta de pavimento
parede e teto
gasket type floor, wall,
ceiling profiles

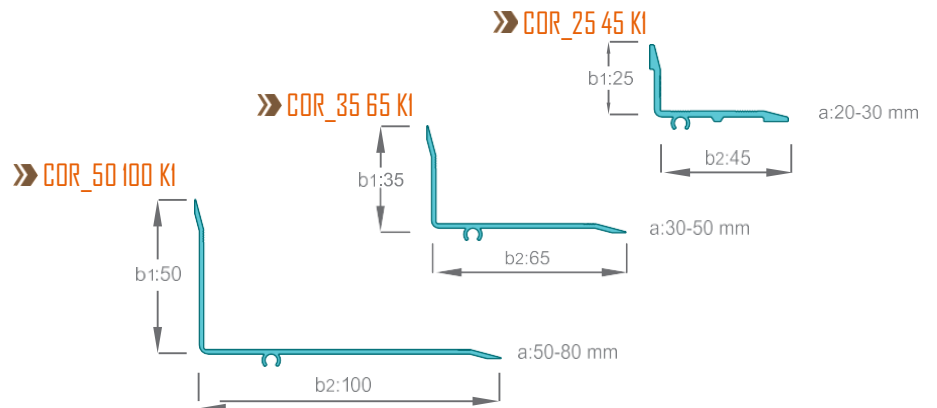
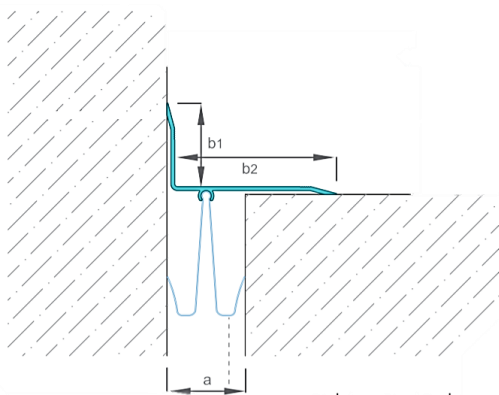

A junta de cobertura de canto é compatível com juntas retas e é usada em pavimentos, paredes e tetos.
Corner cover profile are compatible with straight cover profiles and used in floors, walls and ceilings.





» COR_151 DT



» COR_201 DT

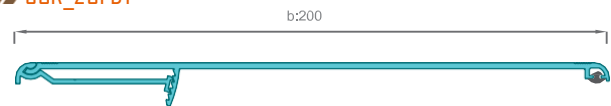

» COR_50 101 K

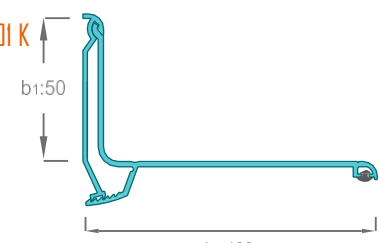

» COR_50 151 K

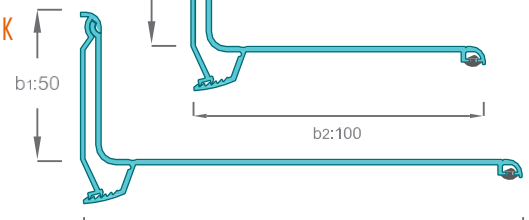

» COR_50 201 K

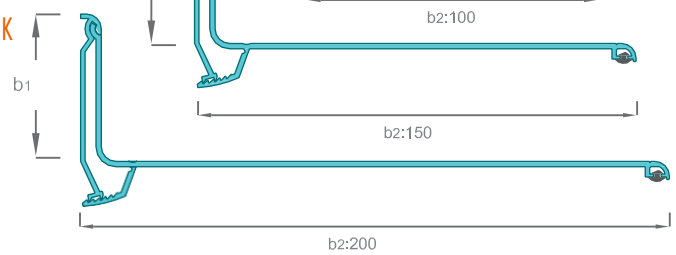

JUNTAS DE COBERTURA EM AÇO INOXIDÁVEL / STAINLESS STEEL COVER PROFILES

» COR_100 ZS

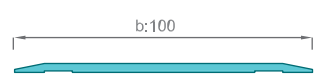

» COR_120 ZS

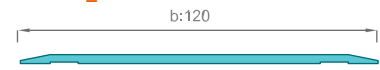

» COR_150 ZS



» COR_200 ZS



» COR_100 DS

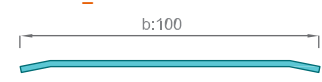

» COR_120 DS

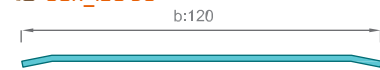

» COR_150 DS

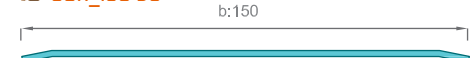

» COR_200 DS

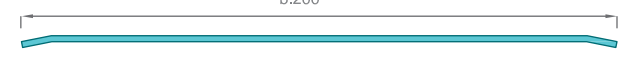

» COR_40 80ZKS

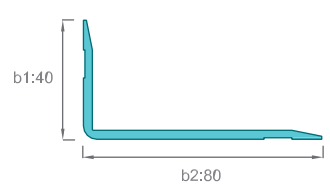

» COR_40 80DKS

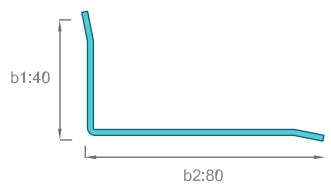

Tipo de junta de pavimento
 parede e teto
 Basket type floor, wall,
 Ceiling profiles

Juntas para pavimento, parede e teto
300 COR series Floor, wall, and ceiling profiles

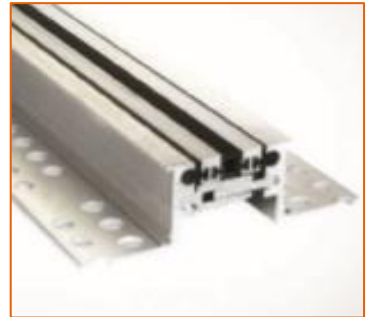

Juntas de dilatação de pavimentos de embutir
Flush mounted floor expansion joint profiles

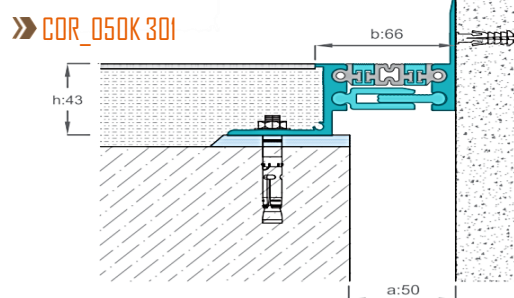
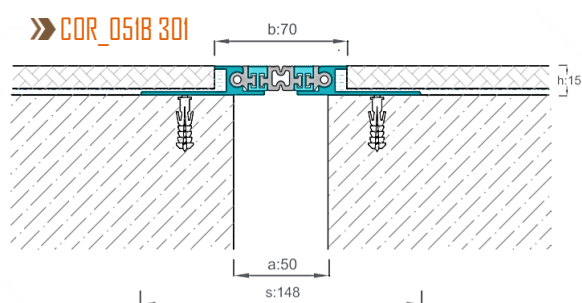
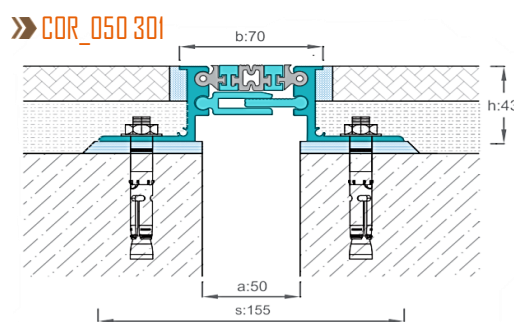
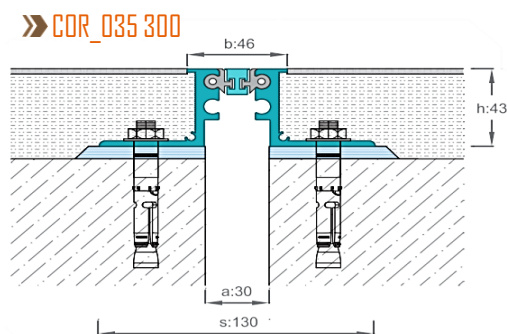

Série 300 de pavimento,
parede e teto
300 series floor, wall,
Ceiling profiles

As juntas de dilatação da série 300 consistem em lamelas de alumínio e juntas de TPE. A série COR 300 pode ser usada em áreas como centros comerciais, edifícios industriais leves, armazéns, hospitais, aeroportos e metros expostos a veículos médios e intensa carga de pedestres. É adequado para muitos tipos de pavimentos, como cerâmica, granito, mármore, contrapiso e pavimentos industriais com várias alturas de pés. Pré-montado e preparado em 3 metros de comprimento para entrega. É fixado ao chão com âncoras com espaçamento de 35 cm em ambos os lados.

The 300 series dilatation profiles consisting of aluminum lamellae and TPE gaskets. The 300 series can be used in areas such as shopping malls, light industrial buildings, warehouses, hospitals, airports and subways which are exposed to medium vehicle and intense pedestrian load. It is suitable for many flooring types such as, ceramic, granite, marble, screed and industrial floors with various foot heights. Pre-mounted and prepared in 3 meters lengths for delivery. It is fixed to the floor with anchors with 35cm spacing on both sides.



REF	DESCRIÇÃO DESCRIPTION	LARGURA DA JUNTA (a) mm JOINT WIDTH	SUPERFÍCIE VISÍVEL (b) mm SURFACE VISIBLE	ALTURA PERFIL (h) mm PROFILE HEIGHT	LARGURA DA TOTAL (s) mm TOTAL WIDTH	SUPERFÍCIE SURFACE	CAPACIDADE MOVIMENTO MOVEMENT CAPACITY	CAPACIDADE CARGA LOAD CAPACITY
COR_035 300	É necessário especificar a altura do pé Foot height is required to be specified	30	46	14/28/43/60/80	130	Acabamento Alu + TPE Mill finish ALU + TPE	±5	30 Ton 6,5 Ton
COR_050 301	Adequado com betonilha, granito, mármore e etc. Suitable with screed, granite, marble and etc.	50	70	43	155	Acabamento Alu + TPE Mill finish ALU + TPE	±10	15 Ton 3,5 Ton
COR_051 301	Adequado com cerâmica. Suitable with ceramic.	50	70	14	155	Acabamento Alu + TPE Mill finish ALU + TPE	+10	+ 1,5 Ton
COR_051B 301	Apropriado com cerâmica e econômico. Suitable with ceramic and economic	50	70	15	148	Acabamento Alu + TPE Mill finish ALU + TPE	+10	
COR_052 301	Adequado com granito natural, mármore e etc. Suitable with natural granite, marble and etc.	50	70	28	155	Acabamento Alu + TPE Mill finish ALU + TPE	±10	2,5 Ton
COR_053 301	Adequado com betonilha, granito, mármore e etc. Suitable with screed, granite, marble and etc.	50	70	60	155	Acabamento Alu + TPE Mill finish ALU + TPE	±10	15 Ton 3,5 Ton
COR_054 301	Adequado com betonilha, granito, mármore e etc. Suitable with screed, granite, marble and etc.	50	70	80	155	Acabamento Alu + TPE Mill finish ALU + TPE	+10	15 Ton 3,5 Ton

Junta de dilatação de pavimento de embutir
Flush mounted floor expansion joint profiles



» COR_100_303

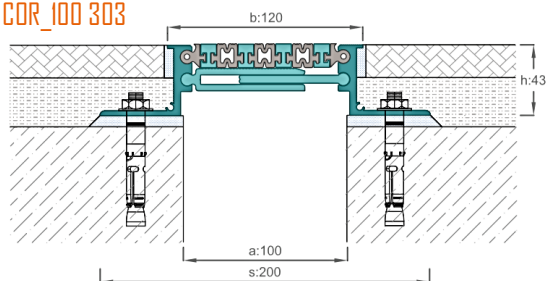

» COR_100k_303

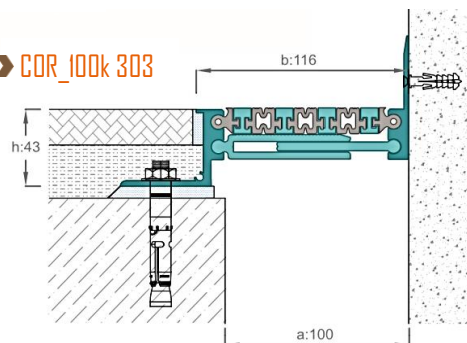

» COR_101_303

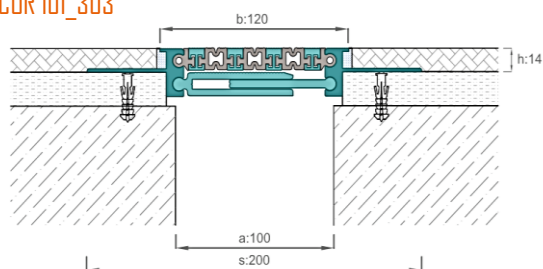

» COR_100_304

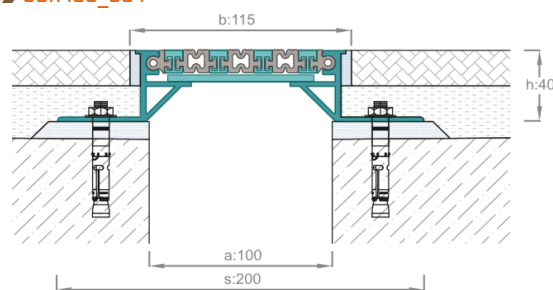

» COR_101B_303



» COR_101_303



» COR_102_303



» COR_100_303



» COR_103_303



» COR_104_303



Série 300 de pavimento,
parede e teto
300 series floor, wall,
Ceiling profiles

As séries COR 303 e 304 podem ser usadas em todos os tipos de edifícios, como centros comerciais, hospitais, prédios governamentais e centros de negócios. Também podem ser usados em áreas expostas ao tráfego de veículos com altura mínima de 43 mm.

303 and 304 series can be used in all kinds of buildings such as shopping centers, hospitals, government buildings and business centres. These can also be used in areas exposed to vehicle traffic with minimum height of 43mm.

REF	DESCRIÇÃO DESCRIPTION	LARGURA DA JUNTA (a) mm JOINT WIDTH	SUPERFÍCIE VISÍVEL (b) mm SURFACE VISIBLE	ALTURA (h) mm PROFILE HEIGHT	LARGURA (s) mm TOTAL WIDTH	SUPERFÍCIE SURFACE	CAPACIDADE MOVIMENTO MOVEMENT CAPACITY	CAPACIDADE CARGA LOAD CAPACITY
COR_081_302	Adequado com cerâmica. Suitable with ceramic.	80	100	14	185	Acabamento Alu + TPE Mill finish ALU + TPE	± 12	
COR_081B_302	Apropriado com cerâmico e económico. Suitable with ceramic and economic	80	100	15	178	Acabamento Alu + TPE Mill finish ALU + TPE	± 12	
COR_082_302	Adequado com granito natural, mármore e etc Suitable with natural granite, marble etc	80	100	28	185	Acabamento Alu + TPE Mill finish ALU + TPE	± 12	+ 1,5 Ton
COR_080_302	Adequado com granito natural, mármore e etc Suitable with natural granite, marble etc.	80	100	43/60/80	185	Acabamento Alu + TPE Mill finish ALU + TPE	± 12	3,5 Ton 2,5 Ton
COR_101_303	Adequado com cerâmica. Suitable with ceramic.	100	120	14	200	Acabamento Alu + TPE Mill finish ALU + TPE	± 15	
COR_101B_303	Apropriado com cerâmico e económico. Suitable with ceramic and economic	100	120	15	193	Acabamento Alu + TPE Mill finish ALU + TPE	± 15	
COR_102_303	Adequado com granito natural, mármore e etc Suitable with natural granite, marble etc.	100	120	28	200	Acabamento Alu + TPE Mill finish ALU + TPE	± 15	
COR_100_303	Adequado com granito natural, mármore e etc Suitable with natural granite, marble etc.	100	120	43/60/80	200	Acabamento Alu + TPE Mill finish ALU + TPE	± 15	3 Ton 1,5 Ton
COR_100_304	Adequado com cerâmica e económico Suitable with granite and economic	100	115	40	200	Acabamento Alu + TPE Mill finish ALU + TPE	± 15	



» COR_150 303

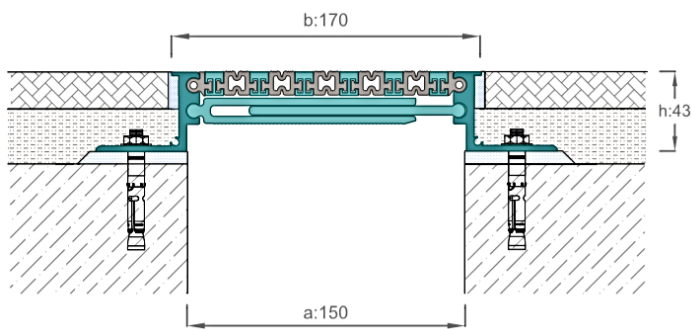

» COR_150K 303

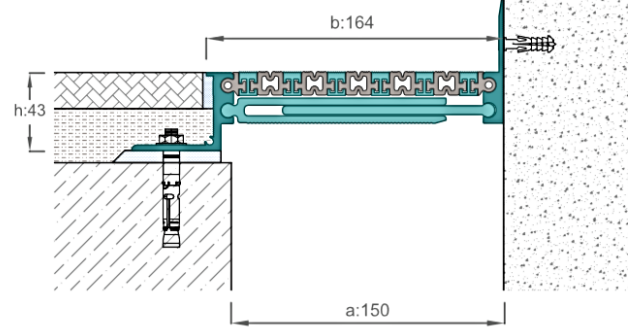

» COR_200 303

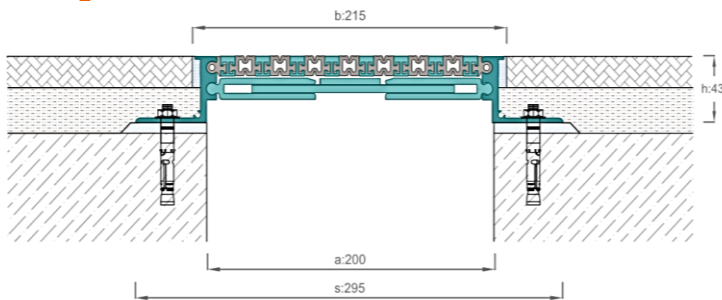

» COR_150 303



» COR_153 303



» COR_154 303



Série 300 de pavimento,
parede e teto
300 series floor, wall,
Ceiling profiles

As juntas de dilatação de pavimento da série COR 300 são usadas para intervalos de 150 mm e 200 mm e geralmente utilizadas em áreas expostas à carga de pedestres. É montado com âncoras de aço e parafusos com espaçamento de 35cm de ambos os lados, montado e preparado em 3 metros de comprimento.

The 300 series floor expansion joint profiles used for 150mm and 200mm gaps and generally utilized in areas exposed to pedestrian load. It is assembled with steel anchors and screws with 35cm spacing from both sides, Mounted and prepared in 3 meters lengths for delivery.



REF	DESCRIÇÃO DESCRIPTION	LARGURA DA JUNTA (a) mm JOINT WIDTH	SUPERFÍCIE VISÍVEL (b) mm SURFACE VISIBLE	ALTURA (h) mm PROFILE HEIGHT	LARGURA (s) mm TOTAL WIDTH	SUPERFÍCIE SURFACE	CAPACIDADE MOVIMENTO MOVEMENT CAPACITY	CAPACIDADE CARGA LOAD CAPACITY
COR_150 303	Adequado granito, mármore e etc. Suitable with granite, marble etc.	150	168	43,60,80	250	Acabamento Alu + TPE Mill finish ALU + TPE	± 25	
COR_200 303	Adequado granito, mármore e etc. Suitable with granite, marble etc.	150	215	43,60,80	295	Acabamento Alu + TPE Mill finish ALU + TPE	± 35	

Junta de dilatação de pavimento de embutir
Flush mounted floor expansion joint profiles



» COR_50 308

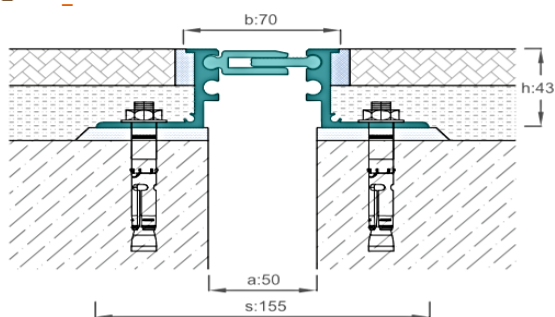

» COR_100 309

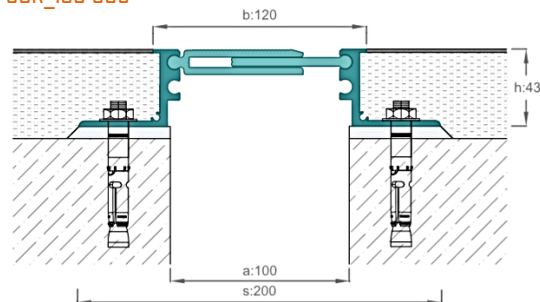

» COR_150 309

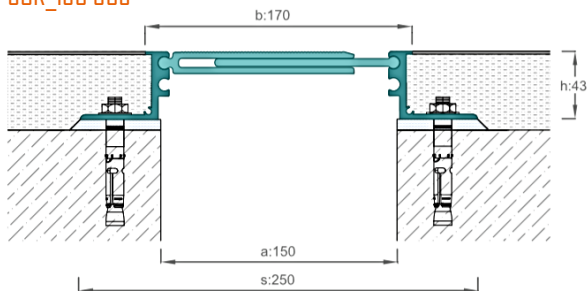

» COR_150K 309

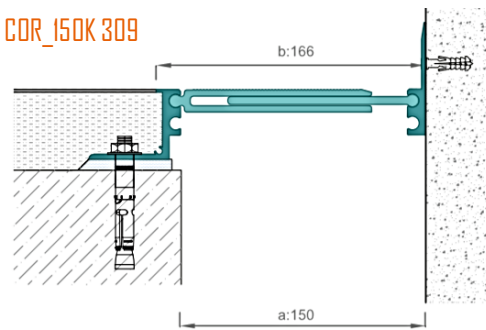

Série 300 de pavimento,
parede e teto
300 series floor, wall,
Ceiling profiles



As junta de dilatação com acabamento horizontal e móvel, horizontal e vertical, são totalmente cobertos na superfície de alumínio.
Horizontally and vertically movable, decorative and economical under finish expansion joint profiles are fully covered in aluminum surface.

REF	DESCRIÇÃO DESCRIPTION	LARGURA DA JUNTA (a) mm JOINT WIDTH	SUPERFÍCIE VISÍVEL (b) mm SURFACE VISIBLE	ALTURA (h) mm PROFILE HEIGHT	LARGURA (s) mm TOTAL WIDTH	SUPERFÍCIE SURFACE	CAPACIDADE MOVIMENTO MOVEMENT CAPACITY	CAPACIDADE CARGA LOAD CAPACITY
COR_051 308	Adequado com cerâmica. Suitable with ceramic.	50	70	14	155	Acabamento Alu Mill finish ALU	± 10	
COR_052 308	Adequado com granito natural, mármore e etc Suitable with natural granite, marble etc.	50	70	28	155	Acabamento Alu Mill finish ALU	± 10	+ 1,5 Ton
COR_050 308	Adequado com granito betonilha, mármore e etc Suitable with natural granite, marble etc.	50	70	43/60/80	155	Acabamento Alu Mill finish ALU	± 10	3,5 Ton 2,5 Ton
COR_080 309	É necessário especificar a altura do pé Footing height is required to be specified.	80	100	14/28/43/60/80	185	Acabamento Alu Mill finish ALU	± 12	3,5 Ton
COR_100 309	É necessário especificar a altura do pé Footing height is required to be specified.	100	120	14/28/43/60/80	200	Acabamento Alu Mill finish ALU	± 15	1,5 Ton
COR_150 309	É necessário especificar a altura do pé Footing height is required to be specified.	150	170	43/60/80	250	Acabamento Alu Mill finish ALU	± 25	

Junta de dilatação de pavimento montados na superfície
 Surface mounted floor expansion joint profiles

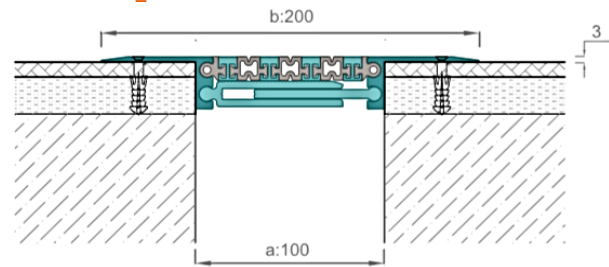
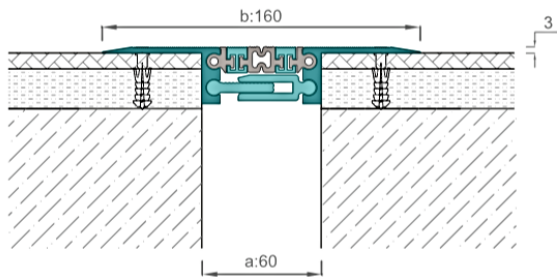

» COR_050 172

» COR_100 174

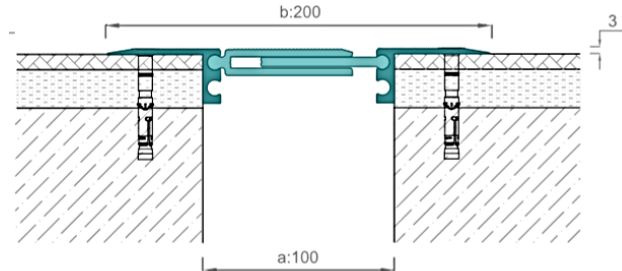
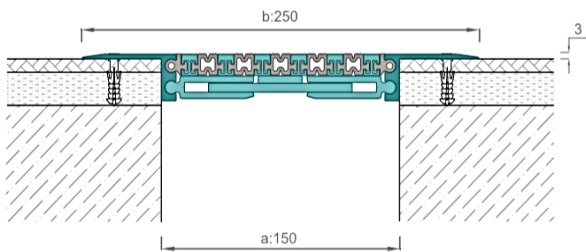

» COR_150 174

» COR_100 184

 Série 300 de pavimento,
 parede e teto
 300 series floor, wall,
 Ceiling profiles

Estas juntas de dilatação são adequadas para folgas de 35 mm a 200 mm. Estas juntas decorativas são fornecidas com orifícios nos dois lados. As opções de vedação TPE estão disponíveis nas cores cinza e preto. Expansion joint profiles suitable for joint gaps from 35mm to 200mm. These decorative profiles come with screw holes on both sides. TPE gasket options available are at grey and black color.



REF	DESCRIÇÃO DESCRIPTION	LARGURA DA JUNTA (a) mm JOINT WIDTH	SUPERFÍCIE VISÍVEL (b) mm SURFACE VISIBLE	ALTURA (h) mm PROFILE HEIGHT	LARGURA (s) mm TOTAL WIDTH	SUPERFÍCIE SURFACE	CAPACIDADE MOVIMENTO MOVEMENT CAPACITY	CAPACIDADE CARGA LOAD CAPACITY
COR_035 171	Adequado com cerâmica. Suitable with ceramic.	35	135	26	135	Acabamento Alu + TPE Mill finish ALU + TPE	± 5	5 Ton 2,5 Ton
COR_050 172	Apropriado com cerâmica e económico. Suitable with ceramic and economic	60	160	26	160	Acabamento Alu + TPE Mill finish ALU + TPE	± 10	3,5 Ton 2 Ton
COR_080 173	Adequado com granito natural, mármore e etc Suitable with natural granite, marble etc.	80	180	26	180	Acabamento Alu + TPE Mill finish ALU + TPE	± 12	2,5 Ton
COR_174 100	Adequado com granito natural, mármore e etc Suitable with natural granite, marble etc.	100	200	26	200	Acabamento Alu + TPE Mill finish ALU + TPE	± 15	
COR_174 150	Adequado com cerâmica. Suitable with ceramic.	150	250	26	250	Acabamento Alu + TPE Mill finish ALU + TPE	± 25	
COR_200 174	Apropriado com cerâmica e económico. Suitable with ceramic and economic	200	300	26	300	Acabamento Alu + TPE Mill finish ALU + TPE	± 35	
COR_050 182	Adequado com granito natural, mármore e etc Suitable with natural granite, marble etc.	60	160	26	160	Acabamento Alumínio Mill finish Aluminium	± 10	3,5 Ton
COR_080 183	Adequado com granito natural, mármore e etc Suitable with natural granite, marble etc.	80	180	26	180	Acabamento Alumínio Mill finish Aluminium	± 12	2,5 Ton
COR_184 100	Adequado com cerâmica e económico Suitable with granite and economic	100	200	26	200	Acabamento Alumínio Mill finish Aluminium	± 15	
COR_150 184	Adequado com cerâmica e económico Suitable with granite and economic	150	250	26	250	Acabamento Alumínio Mill finish Aluminium	± 25	



>> COR_030 208

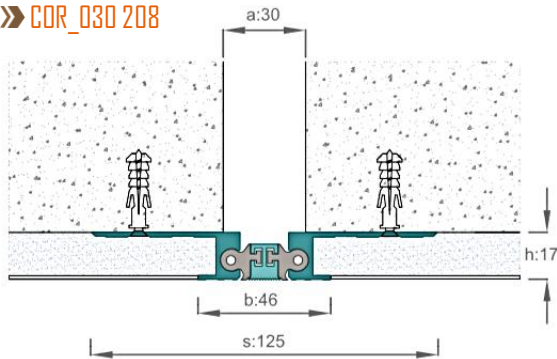

>> COR_050 209

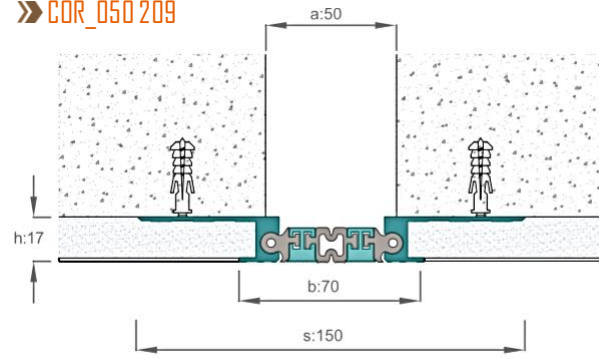

>> COR_100 211

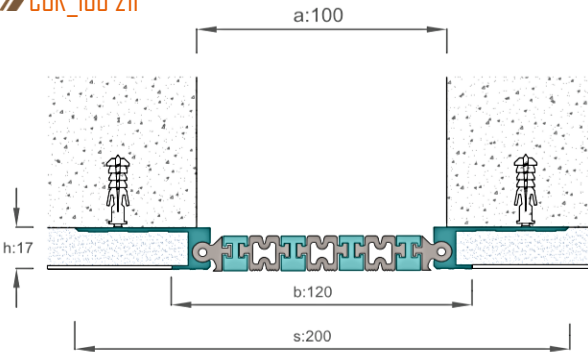

>> COR_100 212

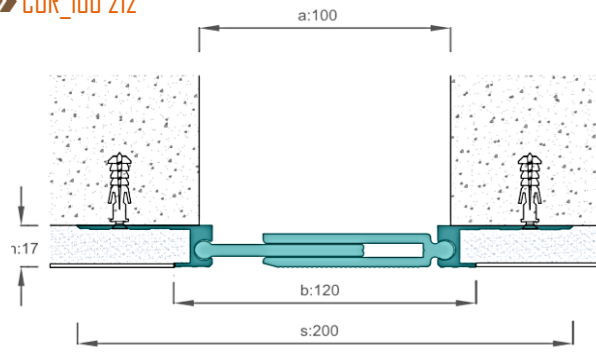

 Série 300 de pavimento,
 parede e teto
 300 series floor, wall,
 ceiling profiles

Adaptável a paredes e tetos compatíveis com as juntas de pavimento da série COR 300. Pode ser usado em revestimentos como gesso, cerâmica e gesso cartonado.
 Adaptable to walls and ceilings which are compatible with COR 300 series floor profiles. Can be used in coverings such as, plaster, ceramic and dry wall.

REF	DESCRIÇÃO DESCRIPTION	LARGURA DA JUNTA (a) mm JOINT WIDTH	SUPERFÍCIE VISÍVEL (b) mm SURFACE VISIBLE	ALTURA PERFIL (h) mm PROFILE HEIGHT	LARGURA DA TOTAL (s) mm TOTAL WIDTH	SUPERFÍCIE SURFACE	CAPACIDADE MOVIMENTO MOVEMENT CAPACITY
COR_030 208	Adequado para betoniha, cerâmica, gesso cartonado / alumínio e superfície superior vedada Suitable with screed, ceramic, dry wall and etc / Aluminium & gasketed top surface	30	46	17	125	Acabamento Alu + TPE Mill finish ALU + TPE	± 5
COR_050 209	Adequado para betoniha, cerâmica, gesso cartonado / alumínio e superfície superior vedada Suitable with screed, ceramic, dry wall and etc / Aluminium & gasketed top surface	50	70	17	150	Acabamento Alu + TPE Mill finish ALU + TPE	± 10
COR_080 210	Adequado para betoniha, cerâmica, gesso cartonado / alumínio e superfície superior vedada Suitable with screed, ceramic, dry wall and etc / Aluminium & gasketed top surface	80	100	17	180	Acabamento Alu + TPE Mill finish ALU + TPE	± 12
COR_100 211	Adequado para betoniha, cerâmica, gesso cartonado / alumínio e superfície superior vedada Suitable with screed, ceramic, dry wall and etc / Aluminium & gasketed top surface	100	120	17	200	Acabamento Alu + TPE Mill finish ALU + TPE	± 14
COR_150 211	Adequado para betoniha, cerâmica, gesso cartonado / alumínio e superfície superior vedada Suitable with screed, ceramic, dry wall and etc / Aluminium & gasketed top surface	150	170	17	250	Acabamento Alu + TPE Mill finish ALU + TPE	± 25
COR_050 212	Adequado para betoniha, cerâmica, gesso cartonado / Superfície de alumínio Suitable with screed, ceramic, dry wall and etc / Aluminium top surface	50	70	17	150	Acabamento Alumínio Mill finish Aluminium	± 10
COR_080 212	Adequado para betoniha, cerâmica, gesso cartonado / Superfície de alumínio Suitable with screed, ceramic, dry wall and etc / Aluminium top surface	80	100	17	180	Acabamento Alumínio Mill finish Aluminium	± 12
COR_100 212	Adequado para betoniha, cerâmica, gesso cartonado / Superfície de alumínio Suitable with screed, ceramic, dry wall and etc / Aluminium top surface	100	120	17	200	Acabamento Alumínio Mill finish Aluminium	± 14
COR_150 212	Adequado para betoniha, cerâmica, gesso cartonado / Superfície de alumínio Suitable with screed, ceramic, dry wall and etc / Aluminium top surface	150	170	17	250	Acabamento Alumínio Mill finish Aluminium	± 25

Junta de dilatação montadas na parede/teto
 Flush mounted wall and ceiling expansion joint profiles

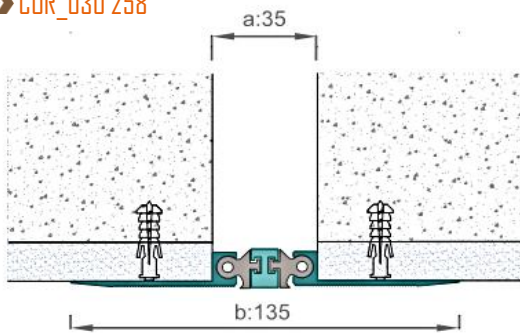

>> COR_030 258

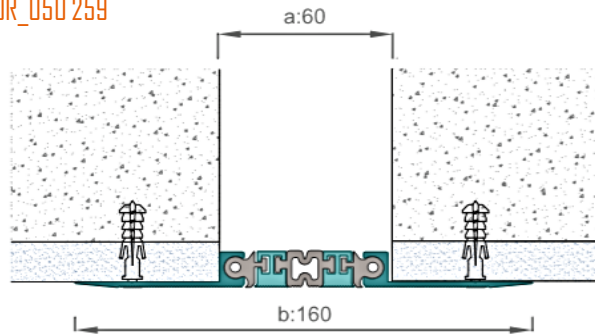

>> COR_050 259

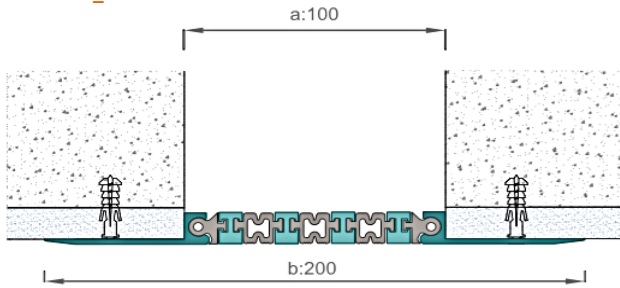

>> COR_100 259

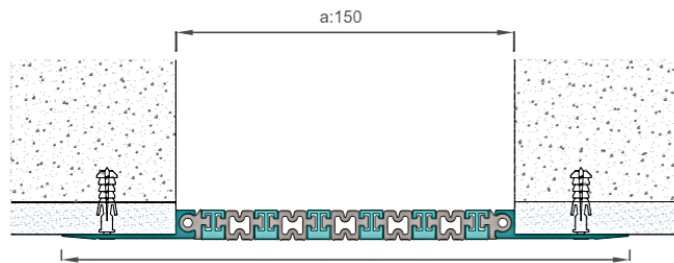

>> COR_150 259

 Série 300 de pavimento,
 parede e teto
 300 series floor, wall,
 ceiling profiles

Adequado para paredes e tetos compatíveis com as juntas de pavimento da série COR 300 e COR 172. Juntas de dilatação montados na superfície montados a partir de orifícios dos parafusos em ambos os lados antes da entrega.

Suitable for walls and ceilings which are compatible with COR 300 and COR 172 series floor profiles. Surface mounted expansion joint profiles fitted from screw holes on both sides before delivery.



REF	DESCRIÇÃO DESCRIPTION	LARGURA DA JUNTA (a) mm JOINT WIDTH	SUPERFÍCIE VISÍVEL (b) mm SURFACE VISIBLE	ALTURA PERFIL (h) mm PROFILE HEIGHT	LARGURA DA TOTAL (s) mm TOTAL WIDTH	SUPERFÍCIE SURFACE	CAPACIDADE MOVIMENTO MOVEMENT CAPACITY
COR_030 258	Acabamento fresado, colocado por parafusos, superfície superior de Alu + TPE Mill finish, screw holed, Alu + TPE top surface	35	135	11	135	Acabamento Alu + TPE Mill finish ALU + TPE	± 5
COR_050 259	Acabamento fresado, colocado por parafusos, superfície superior de Alu + TPE Mill finish, screw holed, Alu + TPE top surface	60	160	11	160	Acabamento Alu + TPE Mill finish ALU + TPE	± 10
COR_080 259	Acabamento fresado, colocado por parafusos, superfície superior de Alu + TPE Mill finish, screw holed, Alu + TPE top surface	80	180	11	180	Acabamento Alu + TPE Mill finish ALU + TPE	± 12
COR_100 259	Acabamento fresado, colocado por parafusos, superfície superior de Alu + TPE Mill finish, screw holed, Alu + TPE top surface	100	200	11	200	Acabamento Alu + TPE Mill finish ALU + TPE	± 14
COR_150 259	Acabamento fresado, colocado por parafusos, superfície superior de Alu + TPE Mill finish, screw holed, Alu + TPE top surface	150	250	11	250	Acabamento Alu + TPE Mill finish ALU + TPE	± 35
COR_200 259	Acabamento fresado, colocado por parafusos, superfície superior de Alu + TPE Mill finish, screw holed, Alu + TPE top surface	200	300	11	300	Acabamento Alumínio Mill finish Aluminium	± 35

Juntas de pavimento pesados e higiênicos
Heavy duty and hygienic floor profiles





» COR_050 703

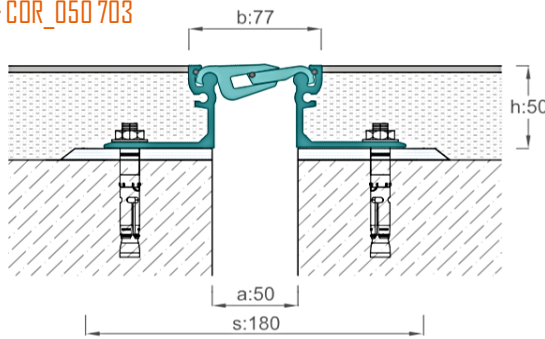

» COR_050K 703

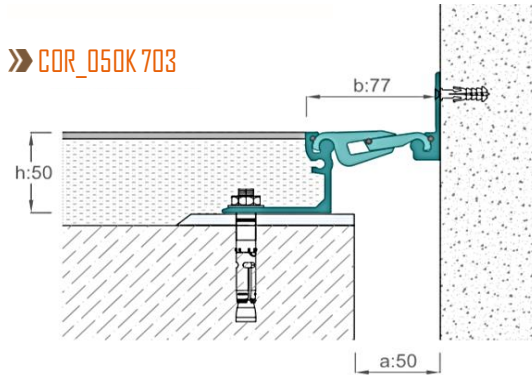

» COR_050 700



» COR_050 701



» COR_050 702

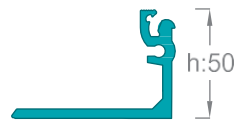

» COR_050 703



» COR_050 704



» COR_050 705

Junta de pavimentos
pesados e higiénicos
Heavy duty and
hygienic floor profiles

As juntas de pavimento série 700 são projetados para serem decorativos, higiênicos e resistentes a cargas pesadas com seção transversal superior especial; juntas confiáveis a longo prazo podem ser usadas em muitos projetos diferentes, como centros comerciais, estruturas industriais pesadas, hospitais e aeroportos, comprimento de produção é de 4 metros.

700 series floor to floor profiles are designed to be decorative, hygienic and resistant to heavy loads with special top cross section, long-term reliable profiles can be used in many different projects such as, shopping malls, heavy industrial structures, hospitals and airports, production length is 4 meters.



REF	DESCRIÇÃO DESCRIPTION	LARGURA DA JUNTA (a) mm JOINT WIDTH	SUPERFÍCIE VISÍVEL (b) mm SURFACE VISIBLE	ALTURA (h) mm PROFILE HEIGHT	LARGURA (s) mm TOTAL WIDTH	SUPERFÍCIE SURFACE	CAPACIDADE MOVIMENTO MOVEMENT CAPACITY	CAPACIDADE CARGA LOAD CAPACITY
COR_050 700	Adequado para shoppings, hospitais / Superfície superior plana Suitable for shopping malls, Hospitals / Flat top surface	50	77	17	180	Acabamento Alumínio Mill finish Aluminium	± 10	3,5 Ton
COR_050 701	Adequado para shoppings, hospitais / Superfície superior plana Suitable for shopping malls, Hospitals / Flat top surface	50	77	30	180	Acabamento Alumínio Mill finish Aluminium	± 10	30 Ton 6,5 Ton
COR_050 702	Adequado para shoppings, hospitais / Superfície superior plana Suitable for shopping malls, Hospitals / Flat top surface	50	77	40	180	Acabamento Alumínio Mill finish Aluminium	± 10	30 Ton 6,5 Ton
COR_050 703	Adequado para shoppings, hospitais / Superfície superior plana Suitable for shopping malls, Hospitals / Flat top surface	50	77	50	180	Acabamento Alumínio Mill finish Aluminium	± 10	30 Ton 6,5 Ton
COR_050 704	Adequado para shoppings, hospitais / Superfície superior plana Suitable for shopping malls, Hospitals / Flat top surface	50	77	60	195	Acabamento Alumínio Mill finish Aluminium	± 10	30 Ton 6,5 Ton
COR_050 705	Adequado para shoppings, hospitais / Superfície superior plana Suitable for shopping malls, Hospitals / Flat top surface	50	77	70	195	Acabamento Alumínio Mill finish Aluminium	± 10	30 Ton 6,5 Ton
COR_080 710	Adequado para shoppings, hospitais / Superfície superior plana Suitable for shopping malls, Hospitals / Flat top surface	80	110	17	210	Acabamento Alumínio Mill finish Aluminium	± 16	2,5 Ton
COR_080 711	Adequado para shoppings, hospitais / Superfície superior plana Suitable for shopping malls, Hospitals / Flat top surface	80	110	30	210	Acabamento Alumínio Mill finish Aluminium	± 16	30 Ton 6,5 Ton
COR_080 712	Adequado para shoppings, hospitais / Superfície superior plana Suitable for shopping malls, Hospitals / Flat top surface	80	110	40	210	Acabamento Alumínio Mill finish Aluminium	± 16	30 Ton 6,5 Ton
COR_080 713	Adequado para shoppings, hospitais / Superfície superior plana Suitable for shopping malls, Hospitals / Flat top surface	80	110	50	210	Acabamento Alumínio Mill finish Aluminium	± 16	30 Ton 6,5 Ton



» COR_100 723

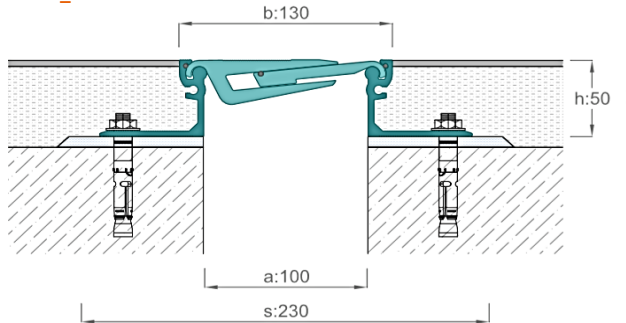

» COR_100K 723

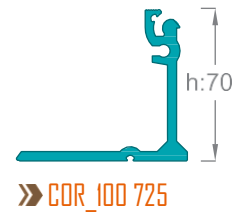
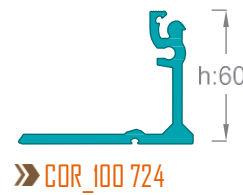
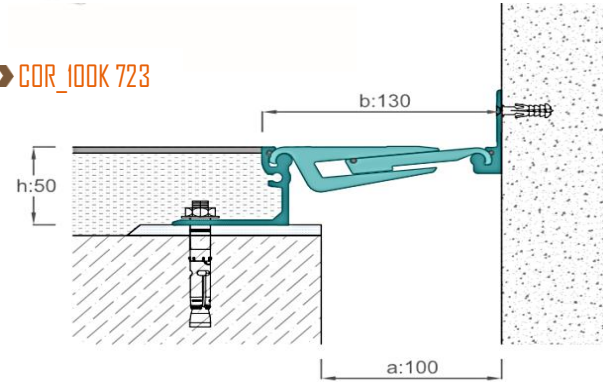

Junta de pavimentos pesados e higiénicos
Heavy duty and hygienic floor profiles

Adequado para coberturas de pavimentos como granito, mármore, cerâmica, betonilha industrial e pavimentos de PVC com diferentes alturas de apoio. Montado no chão com âncoras de aço, com intervalos de 35 cm de ambos os lados. O uso de argamassa epóxi é um passo essencial para evitar possíveis quebras que possam ocorrer nas laterais. Cada projeto tem sua opção de canto disponível, fabricada como no projeto dos detalhes de união T, L +.

Suitable for flooring covers such as, granite, marble, ceramic, industrial screed and PVC floors with different footing heights. Assembled to the floor with steel anchors by having intervals of 35cm from both sides. Using epoxy mortar is an essential step to avoid any possible breakage which can occur at sides. Each design has its corner option available manufactured as in design of T, L + joining detail.



REF	DESCRIÇÃO DESCRIPTION	LARGURA DA JUNTA (a) mm JOINT WIDTH	SUPERFÍCIE VISÍVEL (b) mm SURFACE VISIBLE	ALTURA (h) mm PROFILE HEIGHT	LARGURA (s) mm TOTAL WIDTH	SUPERFÍCIE SURFACE	CAPACIDADE MOVIMENTO MOVEMENT CAPACITY	CAPACIDADE CARGA LOAD CAPACITY
COR_080 714	Adequado para shoppings, hospitais / Superfície superior plana Suitable for shopping malls, Hospitals / Flat top surface	80	110	60	225	Acabamento Alumínio Mill finish Aluminium	± 16	30 Ton 6,5 Ton
COR_080 715	Adequado para shoppings, hospitais / Superfície superior plana Suitable for shopping malls, Hospitals / Flat top surface	80	110	70	225	Acabamento Alumínio Mill finish Aluminium	± 16	30 Ton 6,5 Ton
COR_100 720	Adequado para shoppings, hospitais / Superfície superior plana Suitable for shopping malls, Hospitals / Flat top surface	100	130	17	230	Acabamento Alumínio Mill finish Aluminium	± 20	
COR_100 721	Adequado para shoppings, hospitais / Superfície superior plana Suitable for shopping malls, Hospitals / Flat top surface	100	130	30	230	Acabamento Alumínio Mill finish Aluminium	± 20	30 Ton 6,5 Ton
COR_100 722	Adequado para shoppings, hospitais / Superfície superior plana Suitable for shopping malls, Hospitals / Flat top surface	100	130	40	230	Acabamento Alumínio Mill finish Aluminium	± 20	30 Ton 6,5 Ton
COR_100 723	Adequado para shoppings, hospitais / Superfície superior plana Suitable for shopping malls, Hospitals / Flat top surface	100	130	50	230	Acabamento Alumínio Mill finish Aluminium	± 20	30 Ton 6,5 Ton
COR_100 724	Adequado para shoppings, hospitais / Superfície superior plana Suitable for shopping malls, Hospitals / Flat top surface	100	130	60	245	Acabamento Alumínio Mill finish Aluminium	± 20	30 Ton 6,5 Ton
COR_100 725	Adequado para shoppings, hospitais / Superfície superior plana Suitable for shopping malls, Hospitals / Flat top surface	100	130	70	245	Acabamento Alumínio Mill finish Aluminium	± 20	30 Ton 6,5 Ton

Junta de dilatação de pavimento de embutir
Flush mounted floor expansion joint profiles



» COR_050 820

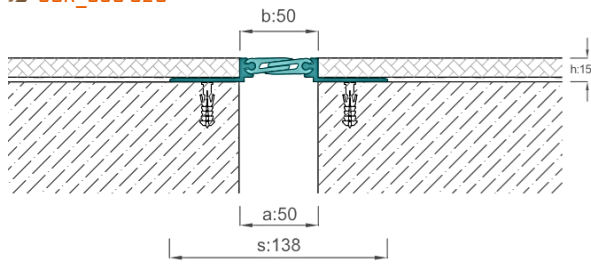

» COR_030 821

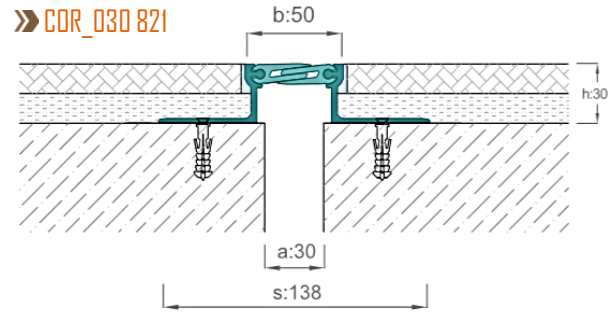

» COR_100 823

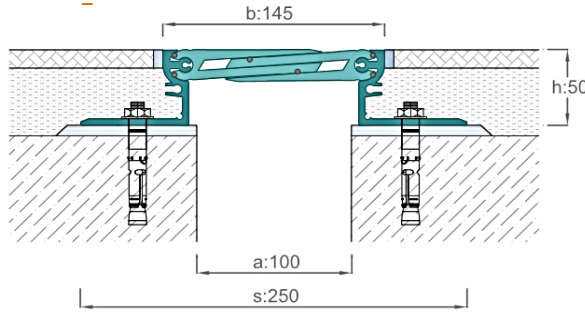

» COR_101 823

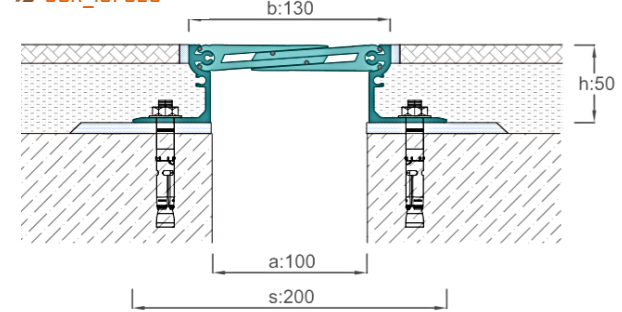

Junta de pavimentos pesados e higiénicos
Heavy duty and hygienic floor profiles

A série COR 800 possui capacidade de movimento tridimensional e é higiênica, resistente a cargas pesadas com diferentes alturas de pé. Adequada para todos os tipos de pavimentos e durável em centros comerciais, hospitais, hotéis e estruturas industriais.

COR 800 series have three-dimensional movement capacity and are hygienic, resistant to heavy loads with different footing heights, Suitable for all kinds of flooring types and durable at shopping centers, hospitals, hotels and industrial structures.



REF	DESCRIÇÃO DESCRIPTION	LARGURA DA JUNTA (a) mm JOINT WIDTH	SUPERFÍCIE VISÍVEL (b) mm SURFACE VISIBLE	ALTURA (h) mm PROFILE HEIGHT	LARGURA (s) mm TOTAL WIDTH	SUPERFÍCIE SURFACE	CAPACIDADE MOVIMENTO MOVEMENT CAPACITY	CAPACIDADE CARGA LOAD CAPACITY
COR_050 820	Adequado para shoppings, hospitais / Superfície superior plana Suitable for shopping malls, Hospitals / Flat top surface	50	50	15	138	Acabamento Alumínio Mill finish Aluminium	± 5	2,5 Ton
COR_030 821	Adequado para shoppings, hospitais / Superfície superior plana Suitable for shopping malls, Hospitals / Flat top surface	30	50	30	138	Acabamento Alumínio Mill finish Aluminium	± 5	9 Ton, 3,5 Ton
COR_100 823	Adequado para shoppings, hospitais / Superfície superior plana Suitable for shopping malls, Hospitals / Flat top surface	100	145	24/40/50/60/70	250	Acabamento Alumínio Mill finish Aluminium	± 20	30 Ton, 6,5 Ton
COR_101 823	Adequado para shoppings, hospitais / Superfície superior plana Suitable for shopping malls, Hospitals / Flat top surface	100	130	50/60/70/90	200	Acabamento Alumínio Mill finish Aluminium	± 18	9 Ton, 3,5 Ton
COR_150 823	Adequado para shoppings, hospitais / Superfície superior plana Suitable for shopping malls, Hospitals / Flat top surface	150	210	65	340	Acabamento Alumínio Mill finish Aluminium	± 30/-25	30 Ton, 6,5 Ton
COR_151 823	Adequado para shoppings, hospitais / Superfície superior plana Suitable for shopping malls, Hospitals / Flat top surface	150	160	50	290	Acabamento Alumínio Mill finish Aluminium	± 20	9 Ton, 3,5 Ton
COR_200 823	Adequado para shoppings, hospitais / Superfície superior plana Suitable for shopping malls, Hospitals / Flat top surface	200	210	65	380	Acabamento Alumínio Mill finish Aluminium	± 30	30 Ton, 6,5 Ton
COR_202 823	Adequado para shoppings, hospitais / Superfície superior plana Suitable for shopping malls, Hospitals / Flat top surface	200	208	50	340	Acabamento Alumínio Mill finish Aluminium	± 30	9 Ton, 3,5 Ton
COR_250 823	Adequado para shoppings, hospitais / Superfície superior plana Suitable for shopping malls, Hospitals / Flat top surface	250	260	65	430	Acabamento Alumínio Mill finish Aluminium	± 45	30 Ton, 6,5 Ton



» COR_150 823

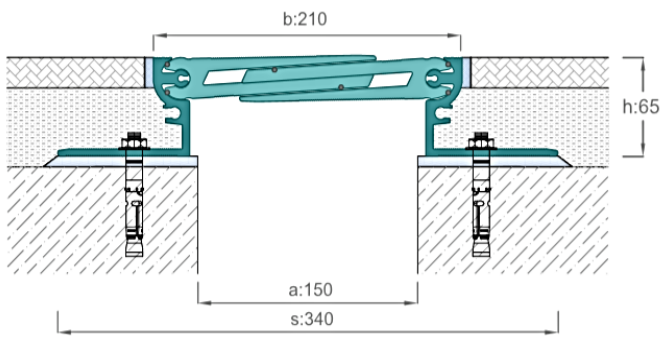

» COR_150K 823

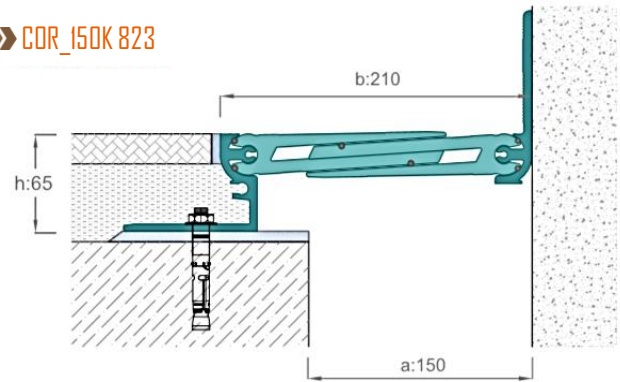

» COR_151 823

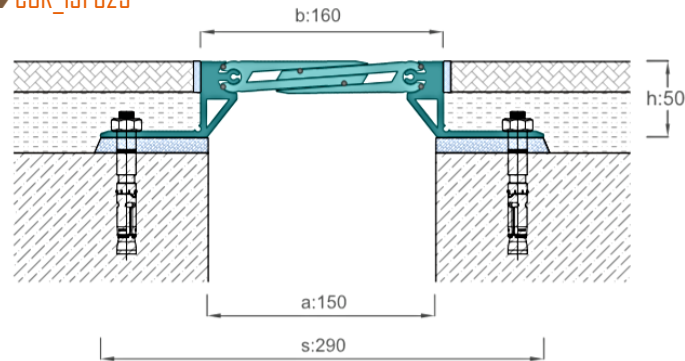

» COR_100 820



» COR_100 822



» COR_100 823



» COR_100 824



» COR_100 825



» COR_101 827

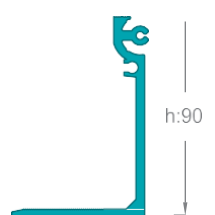

Junta de pavimentos
pesados e higiénicos
Heavy duty and
hygienic floor profiles



» COR_100 821

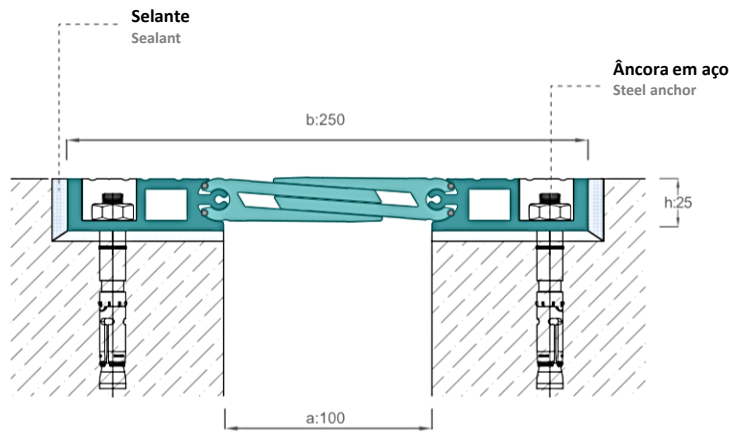

» COR_150 821

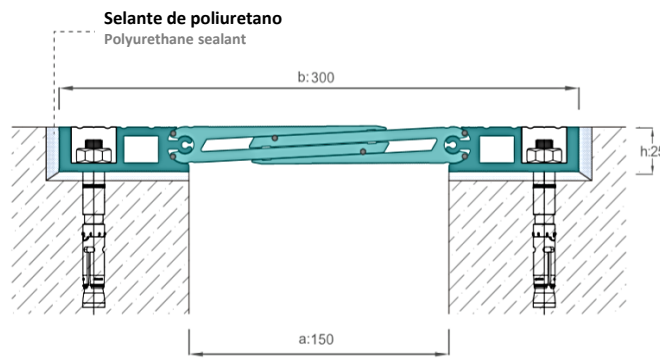

Junta de pavimentos pesados e higiénicos
Heavy duty and hygienic floor profiles

Especial para pavimentos sem cobertura. Facilmente aplicável às pequenas faixas de folga e resistente a cargas pesadas. Nos condutores, são necessárias dimensões de folga de 30 mm x 80 mm para montar essas juntas.
Special for no cover-floors. Easily applicable to the small gap ranges and resistant to heavy loads. At leads, 30mmx80mm gap dimensions are required to assemble these profiles.



REF	DESCRIÇÃO DESCRIPTION	LARGURA DA JUNTA (a) mm JOINT WIDTH	SUPERFÍCIE VISÍVEL (b) mm SURFACE VISIBLE	ALTURA (h) mm PROFILE HEIGHT	LARGURA (s) mm TOTAL WIDTH	SUPERFÍCIE SURFACE	CAPACIDADE MOVIMENTO MOVEMENT CAPACITY	CAPACIDADE CARGA LOAD CAPACITY
COR_100 821	Adequado para estruturas industriais e parques de estacionamento Suitable for industrial structures and car parks	100	250	25	250	Acabamento Alumínio Mill finish Aluminium	± 20	30 Ton 6,5 Ton
COR_150 821	Adequado para estruturas industriais e parques de estacionamento Suitable for industrial structures and car parks	150	300	25	300	Acabamento Alumínio Mill finish Aluminium	± 25	30 Ton 6,5 Ton
COR_200 821	Adequado para estruturas industriais e parques de estacionamento Suitable for industrial structures and car parks	200	350	25	350	Acabamento Alumínio Mill finish Aluminium	± 25	15 Ton 3,5 Ton

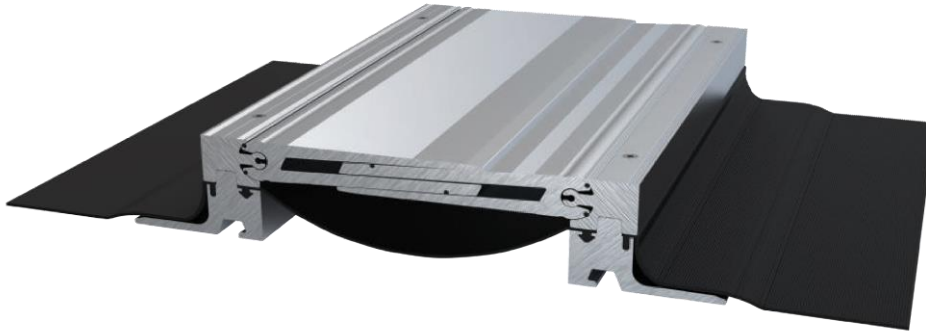

» COR_100 821

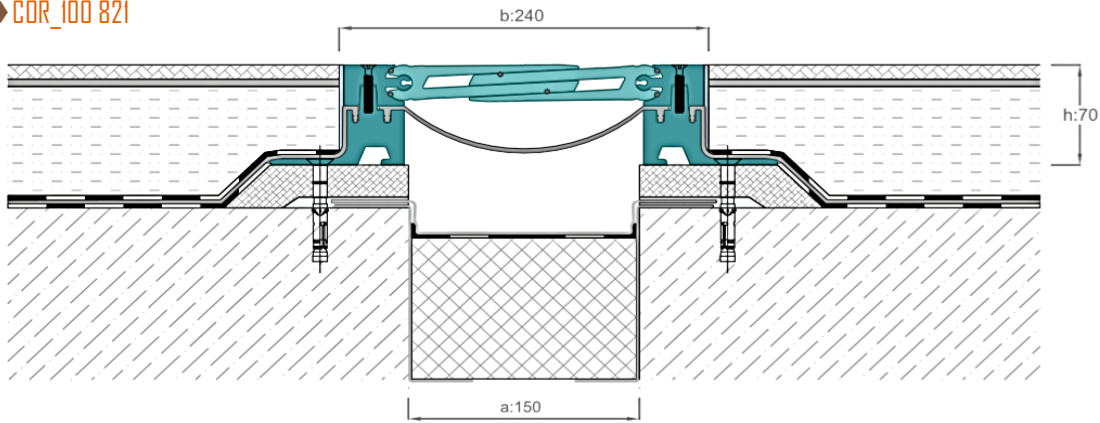

» COR_200 835

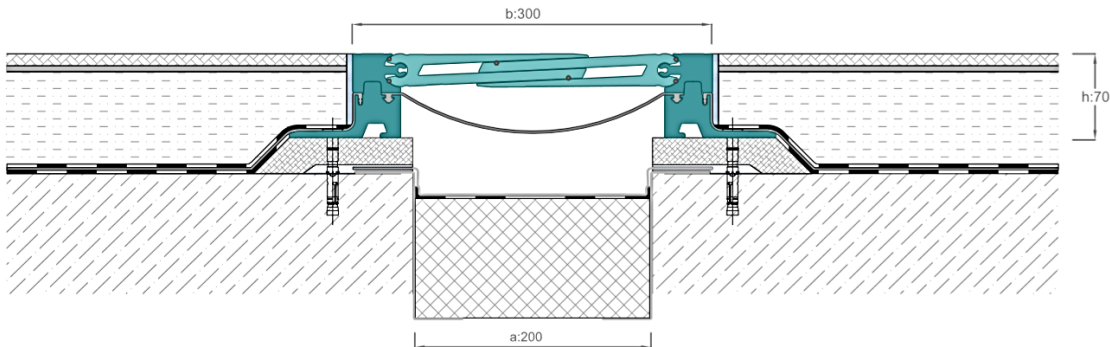

Junta de pavimentos pesados e higiénicos
Heavy duty and hygienic floor profiles

As séries COR 835 são juntas de dilatação de pavimento multiuso. O design higiénico e as peças de impermeabilização removíveis opcionais são resistentes a cargas pesadas. É preferido em aeroportos, centros comerciais, hospitais e áreas úmidas.

COR 835 series are multi-purpose floor expansion joint profiles. Hygienic design and optional removable waterproofing parts are resistant to heavy loads. It is preferred in airports, shopping malls, hospitals and wet areas.



REF	DESCRIÇÃO DESCRIPTION	LARGURA DA JUNTA (a) mm JOINT WIDTH	SUPERFÍCIE VISÍVEL (b) mm SURFACE VISIBLE	ALTURA (h) mm PROFILE HEIGHT	LARGURA (s) mm TOTAL WIDTH	SUPERFÍCIE SURFACE	CAPACIDADE MOVIMENTO MOVEMENT CAPACITY	CAPACIDADE CARGA LOAD CAPACITY
COR_150 835	Adequado para estruturas industriais e parques de estacionamento Suitable for industrial structures and car parks	150	240	70	356	Acabamento Alumínio Mill finish Aluminium	+50/-30	30 Ton 7 Ton
COR_200 835	Adequado para estruturas industriais e parques de estacionamento Suitable for industrial structures and car parks	200	300	70	406	Acabamento Alumínio Mill finish Aluminium	± 50	30 Ton 7 Ton
COR_250 835	Adequado para estruturas industriais e parques de estacionamento Suitable for industrial structures and car parks	250	350	70	456	Acabamento Alumínio Mill finish Aluminium	± 50	16 Ton 3.5 Ton

Junta de dilatação de pavimentos de embutir
Flush mounted floor expansion joint profiles

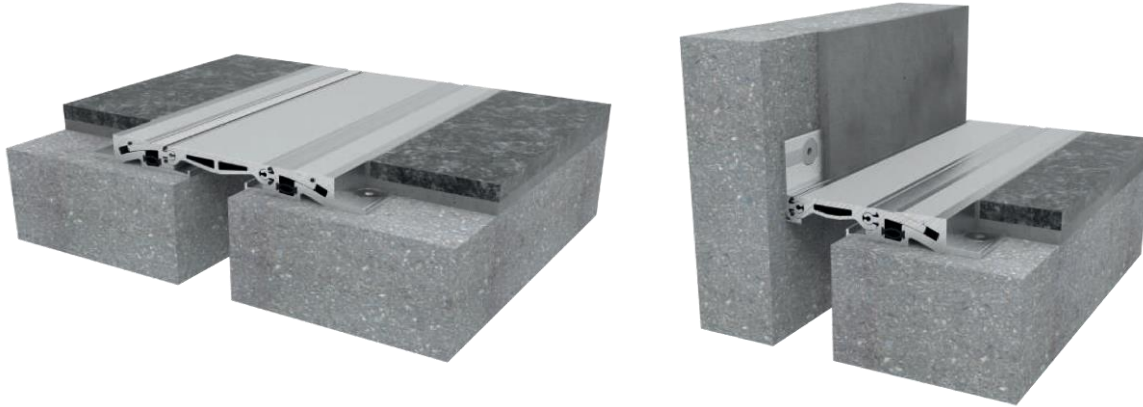

» COR_050 841

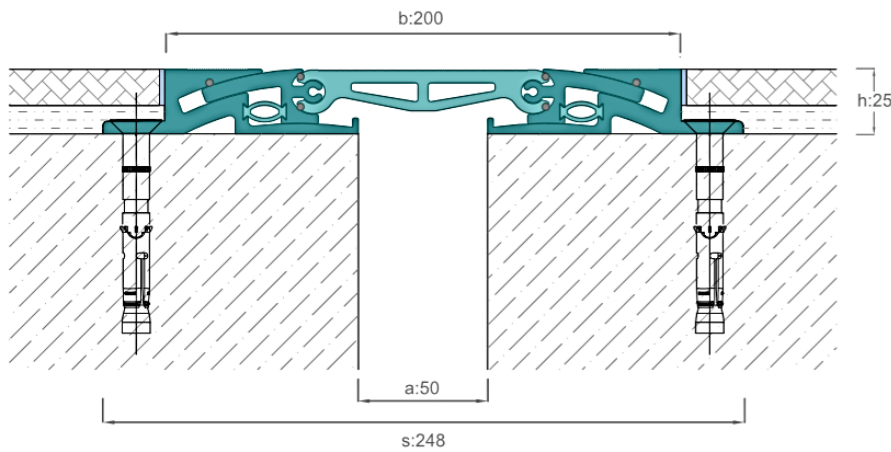

» COR_050K 841

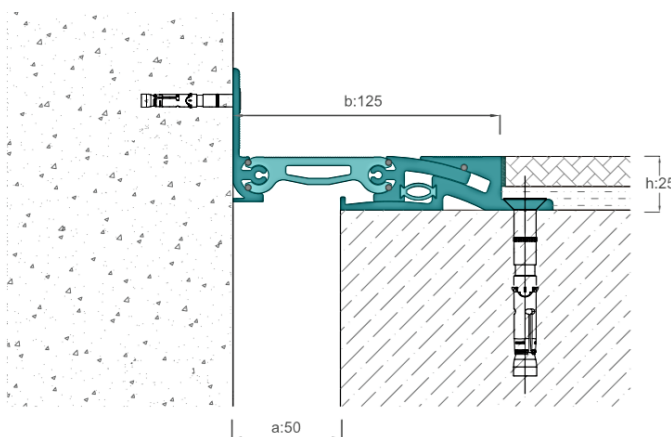

Junta de pavimentos pesados e higiênicos
Heavy duty and hygienic floor profiles

As juntas de dilatação da superfície superior em alumínio são resistentes a cargas pesadas. Móvel em direções tridimensionais e superfície antiderrapante.
Fully aluminum top surface expansion joint profiles are resistant to heavy loads. Movable in three dimensional directions and have non-slip surface.

REF	DESCRIÇÃO DESCRIPTION	LARGURA DA JUNTA (a) mm JOINT WIDTH	SUPERFÍCIE VISÍVEL (b) mm SURFACE VISIBLE	ALTURA (h) mm PROFILE HEIGHT	LARGURA (s) mm TOTAL WIDTH	SUPERFÍCIE SURFACE	CAPACIDADE MOVIMENTO MOVEMENT CAPACITY	CAPACIDADE CARGA LOAD CAPACITY
COR_050 841	Adequado para tráfego intenso de veículos/ Superfície superior de alumínio Suitable for intense vehicle traffic / aluminum top surface	50	200	25	248	Acabamento Alumínio Mill finish Aluminium	± 20	60 Ton 9 Ton
COR_100 841	Adequado para tráfego intenso de veículos/ Superfície superior de alumínio Suitable for intense vehicle traffic / aluminum top surface	100	250	25	298	Acabamento Alumínio Mill finish Aluminium	± 20	60 Ton 9 Ton
COR_150 841	Adequado para tráfego intenso de veículos/ Superfície superior de alumínio Suitable for intense vehicle traffic / aluminum top surface	150	300	25	345	Acabamento Alumínio Mill finish Aluminium	± 20	60 Ton 9 Ton



» COR_100 841

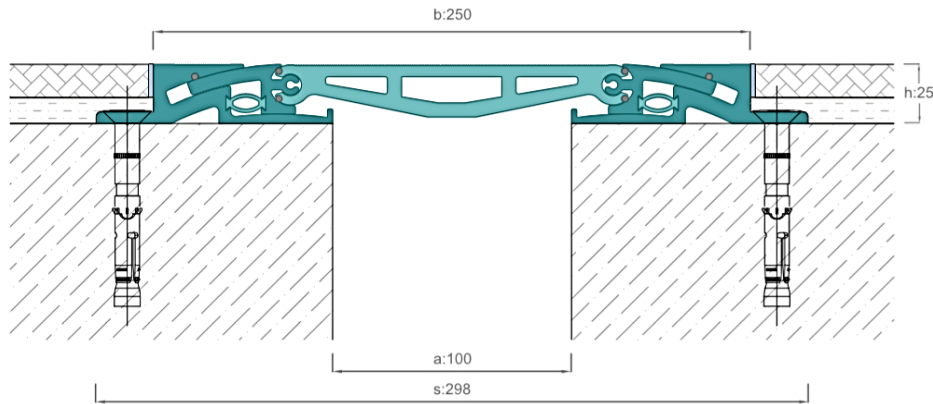

» COR_100K 841

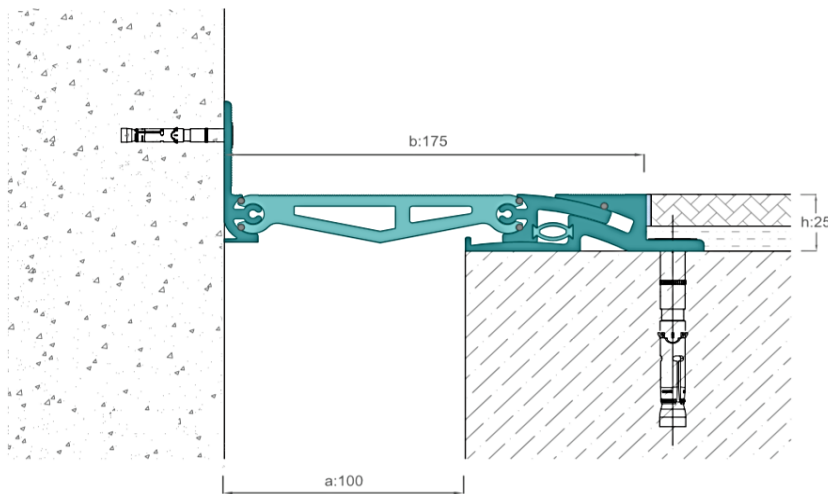

Junta de pavimentos pesados e higiénicos
Heavy duty and hygienic floor profiles





» COR_050 902

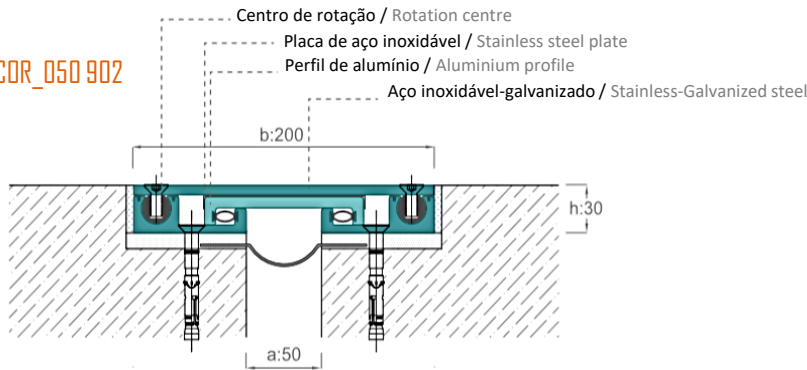

» COR_100 902

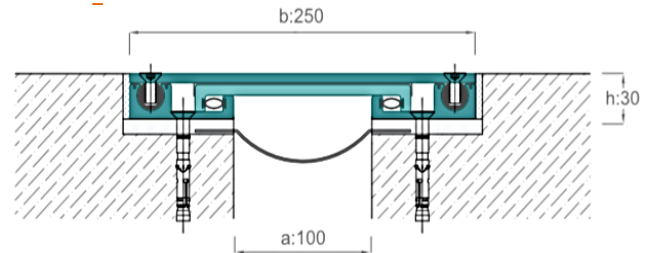

» COR_150 901

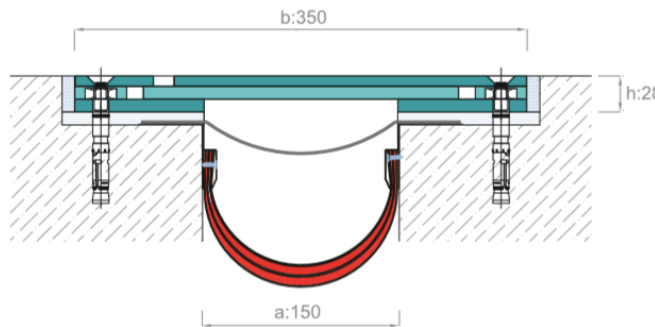

Junta de pavimentos
pesados e higiênicos
Heavy duty and
hygienic floor profiles

» Aplicação de canto/Conner application



Especialmente projetado para resistir a cargas de empilhadeiras e usado em estruturas industriais com características de design linearmente curvado e corpo de aço.
Fabricado como galvanizado por imersão e tipo de aço. T, + detalhes da união também estão disponíveis.
Specially designed to resist forklift loads and used in industrial structures with features of linearly curved design and steel body.
Manufactured as dip galvanized and steel type. T, + joining details are also available.

REF	DESCRIÇÃO DESCRIPTION	LARGURA DA JUNTA (a) mm JOINT WIDTH	SUPERFÍCIE VISÍVEL (b) mm SURFACE VISIBLE	ALTURA (h) mm PROFILE HEIGHT	LARGURA (s) mm TOTAL WIDTH	SUPERFÍCIE SURFACE	CAPACIDADE MOVIMENTO MOVEMENT CAPACITY	CAPACIDADE CARGA LOAD CAPACITY
COR_050 902	Parte inferior de alumínio + superfície superior galvanizada Aluminum bottom part + galvanized top surface	50	200	30	200	Galvanizado Galvanized	± 20	60 Ton 9 Ton
COR_051 902	Parte inferior de alumínio + superfície superior aço inoxidável Aluminum bottom part + stainless steel top surface	50	200	30	200	Aço inoxidável Stainless steel	± 20	60 Ton 9 Ton
COR_052 902	Parte inferior de alumínio + superfície superior alumínio Aluminum bottom part + aluminum top surface	50	200	30	200	Alumínio Aluminium	± 20	60 Ton 9 Ton
COR_050 901	Parte inferior de alumínio + superfície superior galvanizada Aluminum bottom part + galvanized top surface	50	200	28	200	Galvanizado Galvanized	± 10	60 Ton 9 Ton
COR_100 902	Parte inferior de alumínio + superfície superior galvanizada Aluminum bottom part + galvanized top surface	100	250	30	250	Galvanizado Galvanized	± 20	60 Ton 9 Ton
COR_101 902	Parte inferior de alumínio + superfície superior aço inoxidável Aluminum bottom part + stainless steel top surface	100	250	30	250	Aço inoxidável Stainless steel	± 20	60 Ton 9 Ton
COR_102 902	Parte inferior de alumínio + superfície superior alumínio Aluminum bottom part + aluminum top surface	100	250	30	250	Alumínio Aluminium	± 20	60 Ton 9 Ton
COR_100 901	Parte inferior de alumínio + superfície superior galvanizada Aluminum bottom part + galvanized top surface	100	300	28	300	Galvanizado Galvanized	± 10	60 Ton 9 Ton
COR_150 902	Parte inferior de alumínio + superfície superior galvanizada Aluminum bottom part + galvanized top surface	150	300	30	300	Galvanizado Galvanized	± 20	60 Ton 9 Ton
COR_151 902	Parte inferior de alumínio + superfície superior aço inoxidável Aluminum bottom part + stainless steel top surface	150	300	30	300	Aço inoxidável Stainless steel	± 20	60 Ton 9 Ton
COR_152 902	Parte inferior de alumínio + superfície superior alumínio Aluminum bottom part + aluminum top surface	150	300	30	300	Alumínio Aluminium	± 20	60 Ton 9 Ton
COR_150 901	Parte inferior de alumínio + superfície superior galvanizada Aluminum bottom part + galvanized top surface	150	350	28	350	Galvanizado Galvanized	± 10	60 Ton 9 Ton
COR_200 901	Parte inferior de alumínio + superfície superior galvanizada Aluminum bottom part + galvanized top surface	200	400	30	400	Galvanizado Galvanized	± 10	60 Ton 9 Ton

Junta de dilatação de pavimentos montados a superfície
 Surface mounted floor expansion joint profiles

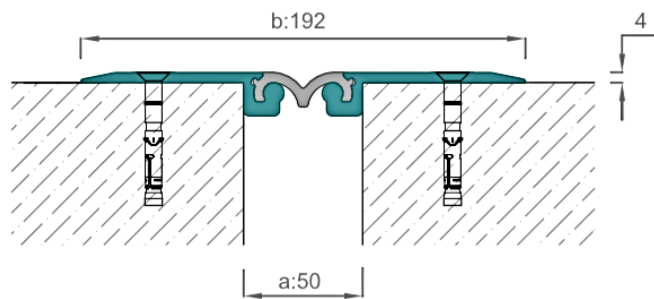

» COR_050 753

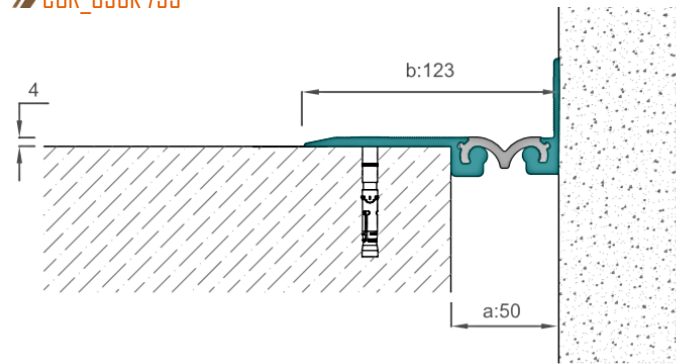

» COR_050K 753

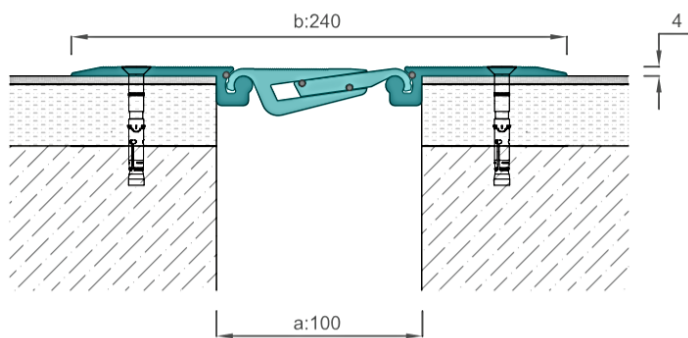

» COR_100 773

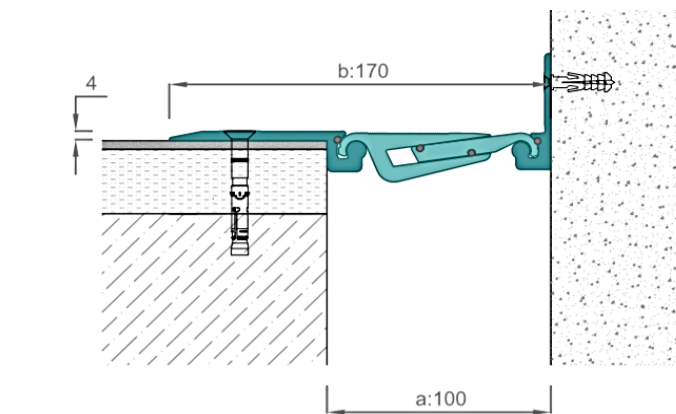

» COR_100K 773

 Juntas de pavimentos pesados e higiénicos
 Heavy duty and hygienic floor profiles

As juntas de pavimentos montados na superfície são resistentes ao tráfego de veículos leves. Pode ser aplicado em revestimentos de pavimentos acabados, como pavimentos de betão bruto. Montado no chão com âncoras de aço.

Surface mounted floor profiles are resistant to light vehicle traffic. Can be applied on finished floor covers such as gross concrete floors. Assembled to the floor with steel anchors.



REF	DESCRIÇÃO DESCRIPTION	LARGURA DA JUNTA (a) mm JOINT WIDTH	SUPERFÍCIE VISÍVEL (b) mm SURFACE VISIBLE	ALTURA (h) mm PROFILE HEIGHT	LARGURA (s) mm TOTAL WIDTH	SUPERFÍCIE SURFACE	CAPACIDADE MOVIMENTO MOVEMENT CAPACITY	CAPACIDADE CARGA LOAD CAPACITY
COR_050 753	Adequado para tráfego intenso de veículos/ Superfície superior de alumínio Suitable for intense vehicle traffic / aluminum top surface	50	192	14	192	Acabamento Alu + TPE Mill finish Alu + TPE	+10	9 Ton 5 Ton
COR_080 763	Adequado para tráfego intenso de veículos/ Superfície superior de alumínio Suitable for intense vehicle traffic / aluminum top surface	80	220	14	220	Acabamento Alumínio Mill finish Aluminium	+10	9 Ton 3,5 Ton
COR_100 773	Adequado para tráfego intenso de veículos/ Superfície superior de alumínio Suitable for intense vehicle traffic / aluminum top surface	100	240	14	240	Acabamento Alumínio Mill finish Aluminium	+12	6 Ton 1,5 Ton

Junta de dilatação de pavimentos montados a superfície
Surface mounted floor expansion joint profiles



» COR_050 883

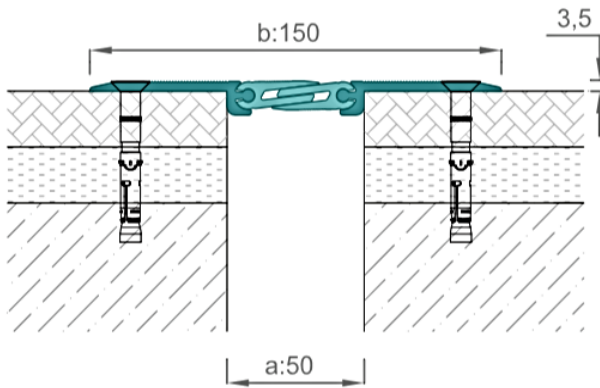

» COR_050K 883

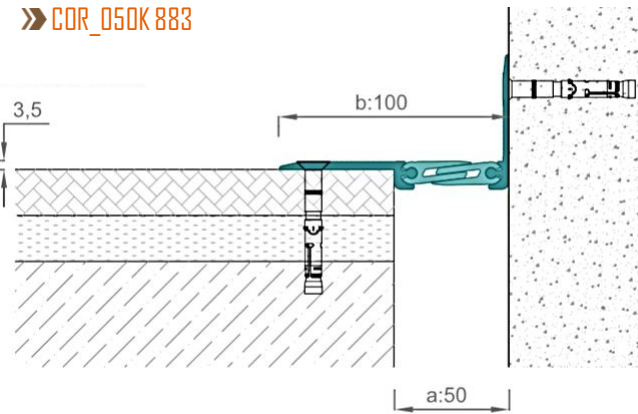

» COR_100 883

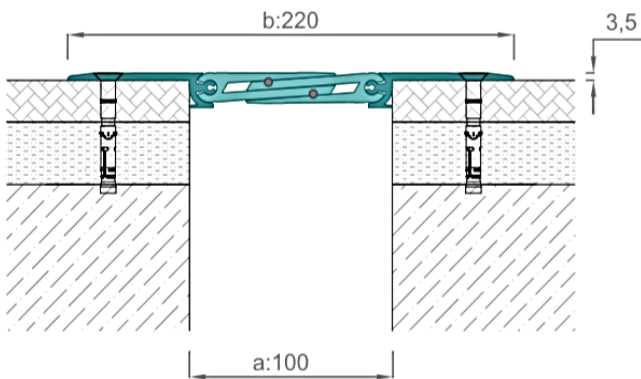

» COR_100K 883

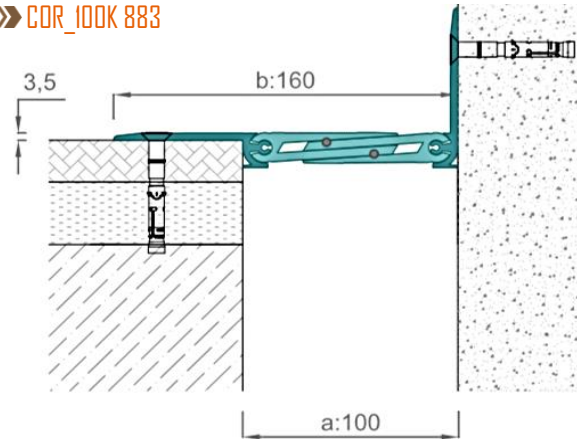

Junta de pavimentos pesados e higiénicos
Heavy duty and hygienic floor profiles

As juntas de pavimentos montadas em superfície têm capacidade para se mover em direções tridimensionais.
Surface Mounted floor profiles have the capacity to move in three dimensional directions



REF	DESCRIÇÃO DESCRIPTION	LARGURA DA JUNTA (a) mm JOINT WIDTH	SUPERFÍCIE VISÍVEL (b) mm SURFACE VISIBLE	ALTURA (h) mm PROFILE HEIGHT	LARGURA (s) mm TOTAL WIDTH	SUPERFÍCIE SURFACE	CAPACIDADE MOVIMENTO MOVEMENT CAPACITY	CAPACIDADE CARGA LOAD CAPACITY
COR_050 883	Adequado para parques de estacionamento / furos escareados Suitable for car parks / countersunk holes	50	150	10	150	Acabamento Aluminio Mill finish Aluminium	± 5	1,5 Ton
COR_100 883	Adequado para parques de estacionamento / furos escareados Suitable for car parks / countersunk holes	100	220	13	220	Acabamento Aluminio Mill finish Aluminium	± 12	6 Ton
COR_150 883	Adequado para parques de estacionamento / furos escareados Suitable for car parks / countersunk holes	150	300	20	300	Acabamento Aluminio Mill finish Aluminium	± 25	3,5 Ton
COR_200 883	Adequado para parques de estacionamento / furos escareados Suitable for car parks / countersunk holes	200	350	26	350	Acabamento Aluminio Mill finish Aluminium	+40/-15	3,5 Ton

Juntas de dilatação sísmicas
Seismic expansion joint profiles

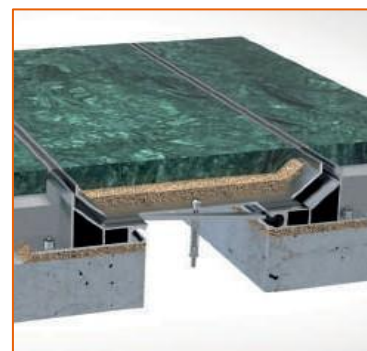
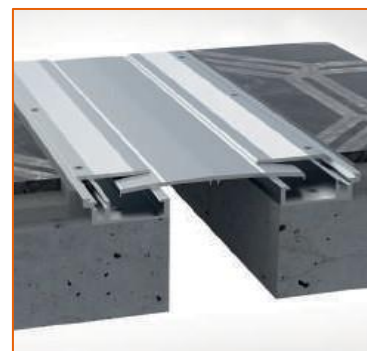
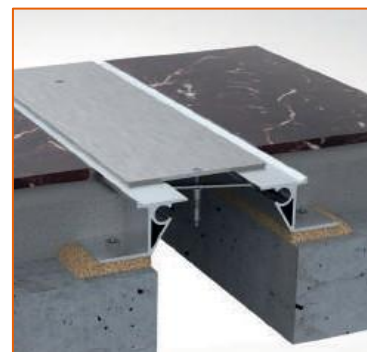
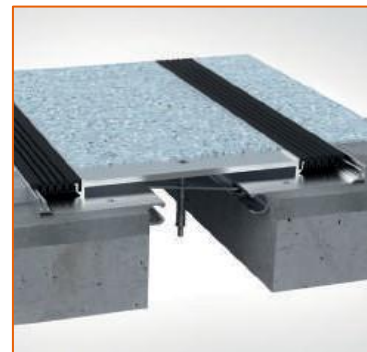

Juntas de dilatação de pavimentos sísmicas de embutir
Flush mounted seismic floor joint profiles



» COR_100 802

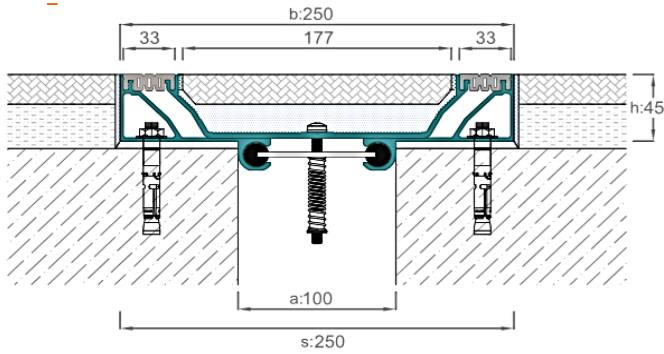

» COR_150 802

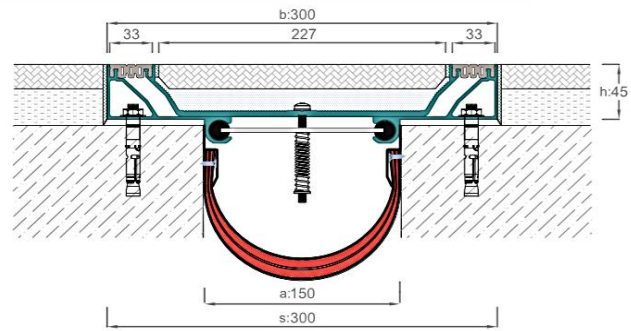

» COR_150K 802

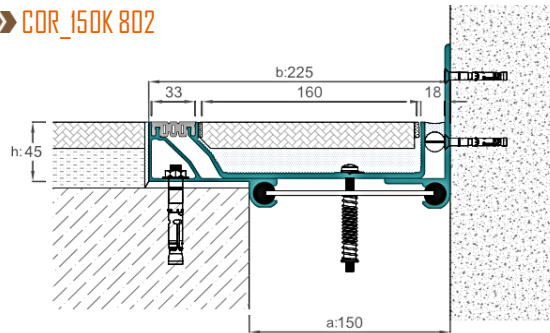

Juntas sísmicas de pavimentos, parede e teto
Seismic floor, wall, ceiling profiles

Adequado para coberturas de pavimento de baixo nível, como coberturas de PVC e epóxi. Alta capacidade móvel e grandes juntas de vedação em TPE são utilizáveis para pavimentos.
Suitable for low levelled floor covers such as PVC and epoxy covers. High movable capacity and large TPE gasketed profiles are usable for floors.



REF	DESCRIÇÃO DESCRIPTION	LARGURA DA JUNTA (a) mm JOINT WIDTH	SUPERFÍCIE VISÍVEL (b) mm SURFACE VISIBLE	ALTURA (h) mm PROFILE HEIGHT	LARGURA (s) mm TOTAL WIDTH	SUPERFÍCIE SURFACE	CAPACIDADE MOVIMENTO MOVEMENT CAPACITY	CAPACIDADE CARGA LOAD CAPACITY
COR_100 802	Junta sísmica de pavimento com junta de dilatação Seismic floor expansion joint profile with gasket	100	250	45	250	Acabamento Alumínio Mill finish Aluminium	± 50	+ Maq. Limpeza Cleaning machine
COR_150 802	Junta sísmica de pavimento com junta de dilatação Seismic floor expansion joint profile with gasket	150	300	45	300	Acabamento Alumínio Mill finish Aluminium	± 70	+ Maq. Limpeza Cleaning machine
COR_200 802	Junta sísmica de pavimento com junta de dilatação Seismic floor expansion joint profile with gasket	200	400	45	400	Acabamento Alumínio Mill finish Aluminium	+100/-80	+ Maq. Limpeza Cleaning machine
COR_250 802	Junta sísmica de pavimento com junta de dilatação Seismic floor expansion joint profile with gasket	250	480	60	480	Acabamento Alumínio Mill finish Aluminium	± 125	+ Maq. Limpeza Cleaning machine
COR_300 802	Junta sísmica de pavimento com junta de dilatação Seismic floor expansion joint profile with gasket	300	600	60	600	Acabamento Alumínio Mill finish Aluminium	± 150	+ Maq. Limpeza Cleaning machine
COR_350 802	Junta sísmica de pavimento com junta de dilatação Seismic floor expansion joint profile with gasket	350	650	60	650	Acabamento Alumínio Mill finish Aluminium	± 175	+ Maq. Limpeza Cleaning machine
COR_400 802	Junta sísmica de pavimento com junta de dilatação Seismic floor expansion joint profile with gasket	400	700	60	700	Acabamento Alumínio Mill finish Aluminium	+175/-200	+ Maq. Limpeza Cleaning machine
COR_450 802	Junta sísmica de pavimento com junta de dilatação Seismic floor expansion joint profile with gasket	450	750	60	750	Acabamento Alumínio Mill finish Aluminium	+175/-225	+ Maq. Limpeza Cleaning machine
COR_500 802	Junta sísmica de pavimento com junta de dilatação Seismic floor expansion joint profile with gasket	500	800	60	800	Acabamento Alumínio Mill finish Aluminium	+175/-250	+ Maq. Limpeza Cleaning machine



» COR 100_803

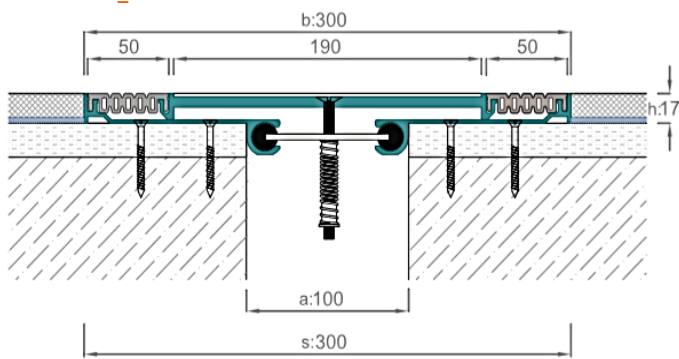

» COR 150_803

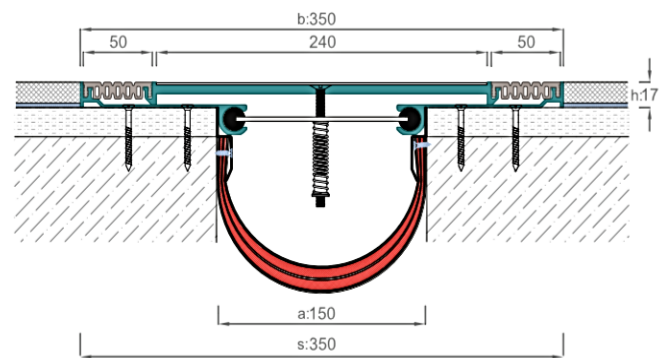

» COR 150K_803

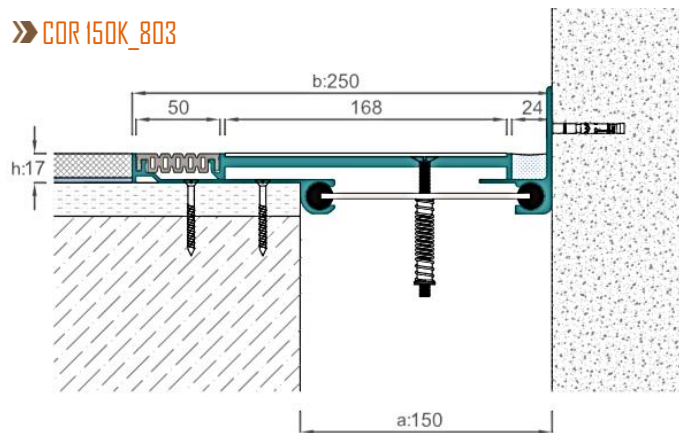

 Juntas sísmicas de pavimentos, parede e teto
 Seismic floor, wall, Ceiling profiles

Adequado para coberturas de pavimento de baixo nível, como coberturas de PVC e epóxi.
 Alta capacidade móvel e grandes perfis de vedação TPE são utilizáveis para pavimentos.
 Suitable for low levelled floor covers such as PVC and epoxy covers. High movable capacity and large TPE gasketed profiles are usable for floors.

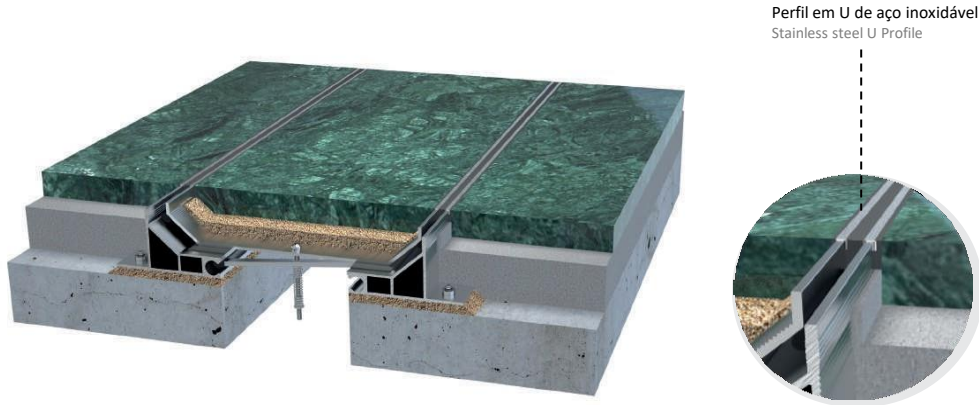

REF	DESCRIÇÃO DESCRIPTION	LARGURA DA JUNTA (a) mm JOINT WIDTH	SUPERFÍCIE VISÍVEL (b) mm SURFACE VISIBLE	ALTURA (h) mm PROFILE HEIGHT	LARGURA (s) mm TOTAL WIDTH	SUPERFÍCIE SURFACE	CAPACIDADE MOVIMENTO MOVEMENT CAPACITY	CAPACIDADE CARGA LOAD CAPACITY
COR_100 803	Adequado para revestimento de pavimentos em PVC / Com junta Suitable for PVC floor cover / gasketed	100	300	17	300	Acabamento Alu + TPE + Tampa Mill finish Alu + TPE + Cover	± 50	+ Maq. Limpeza Cleaning machine
COR_150 803	Adequado para revestimento de pavimentos em PVC / Com junta Suitable for PVC floor cover / gasketed	150	350	17	350	Acabamento Alu + TPE + Tampa Mill finish Alu + TPE + Cover	± 75	+ Maq. Limpeza Cleaning machine
COR_200 803	Adequado para revestimento de pavimentos em PVC / Com junta Suitable for PVC floor cover / gasketed	200	400	17	400	Acabamento Alu + TPE + Tampa Mill finish Alu + TPE + Cover	± 100	+ Maq. Limpeza Cleaning machine

Juntas de dilatação de pavimentos sísmicas de embutir
Flush mounted seismic floor joint profiles



Perfil em U de aço inoxidável
Stainless steel U Profile

» COR 100_804

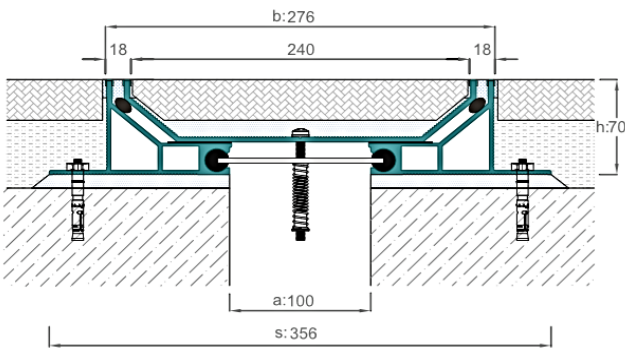

» COR 150_804

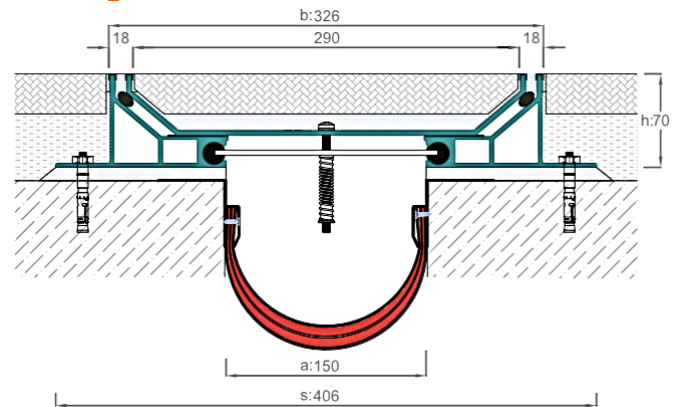

» COR 150K_804

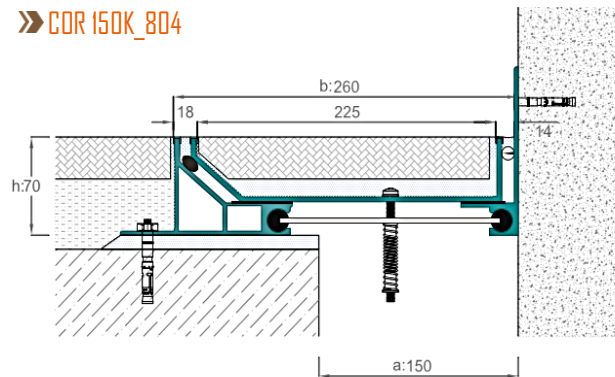

Juntas sísmicas de pavimentos, parede e teto
Seismic floor, wall, Ceiling profiles

Projetado para aplicar em grandes espaços e fornecer pequenas porções visíveis. Mesmo assim, a série COR 803 tem menos capacidade de movimento em comparação com outras juntas sísmicas, mas o design decorativo ainda o torna especial.
Designed to apply on large gaps and provide small visible portions. Even though, COR 803 series has less movement capacity compared to other seismic profiles, the decorative design still makes it special to be preferred.



REF	DESCRIÇÃO DESCRIPTION	LARGURA DA JUNTA (a) mm JOINT WIDTH	SUPERFÍCIE VISÍVEL (b) mm SURFACE VISIBLE	ALTURA (h) mm PROFILE HEIGHT	LARGURA (s) mm TOTAL WIDTH	SUPERFÍCIE SURFACE	CAPACIDADE MOVIMENTO MOVEMENT CAPACITY	CAPACIDADE CARGA LOAD CAPACITY
COR_100_804	Superfície superior em aço inox + aplicação de selante Stainless steel top surface + Sealant application	100	276	70	356	Aço inoxidável + Selante + Tampa Stainless steel + Sealant + Cover	± 50	+ Maq. Limpeza Cleaning machine
COR_150_804	Superfície superior em aço inox + aplicação de selante Stainless steel top surface + Sealant application	150	326	70	406	Aço inoxidável + Selante + Tampa Stainless steel + Sealant + Cover	± 75	+ Maq. Limpeza Cleaning machine
COR_200_804	Superfície superior em aço inox + aplicação de selante Stainless steel top surface + Sealant application	200	376	70	456	Aço inoxidável + Selante + Tampa Stainless steel + Sealant + Cover	± 75	+ Maq. Limpeza Cleaning machine
COR_250_804	Superfície superior em aço inox + aplicação de selante Stainless steel top surface + Sealant application	250	426	70	506	Aço inoxidável + Selante + Tampa Stainless steel + Sealant + Cover	± 75	+ Maq. Limpeza Cleaning machine
COR_300_804	Superfície superior em aço inox + aplicação de selante Stainless steel top surface + Sealant application	300	590	70	671	Aço inoxidável + Selante + Tampa Stainless steel + Sealant + Cover	± 75	+ Maq. Limpeza Cleaning machine

Juntas de dilatação de pavimentos sísmicas de embutir
 Flush mounted seismic floor joint profiles

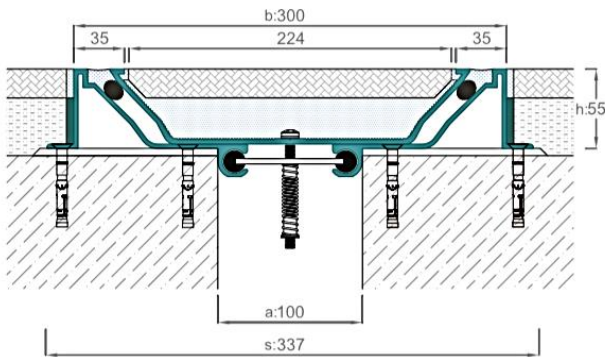

» COR 100_806

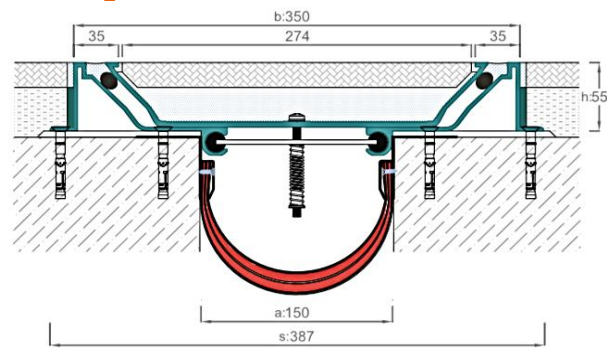

» COR 150_806

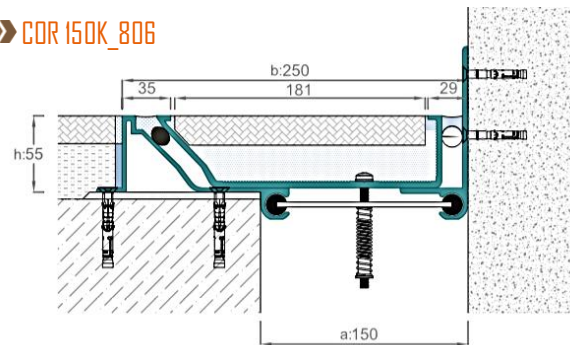

» COR 150K_806

 Juntas sísmicas de pavimentos, parede e teto
 Seismic floor, wall, Ceiling profiles

As séries COR 806 são opções econômicas e alternativas as juntas de dilatação sísmicas de pavimento para ter alta capacidade de movimento. Eles são aplicáveis a grandes lacunas com superfície visível muito estreita. Adequado para todos os tipos de pavimentos. Massa epóxi usada na parte do meio para evitar rachaduras ou danos podem ocorrer na cobertura do pavimento.

COR 806 series are economic and alternative options to floor seismic expansion joint profiles to have high movement capacity. They are applicable to large gaps with very narrow visible surface. Suitable for all flooring types. Epoxy filler used in middle part to avoid any cracks or damages could occur to floor cover.



REF	DESCRIÇÃO DESCRIPTION	LARGURA DA JUNTA (a) mm JOINT WIDTH	SUPERFÍCIE VISÍVEL (b) mm SURFACE VISIBLE	ALTURA (h) mm PROFILE HEIGHT	LARGURA (s) mm TOTAL WIDTH	SUPERFÍCIE SURFACE	CAPACIDADE MOVIMENTO MOVEMENT CAPACITY	CAPACIDADE CARGA LOAD CAPACITY
COR_100_806	Junta sísmica aplicada no selante Sealant applied seismic floor profile	100	300	55	337	Acabamento Alu + Selante + Revestimento piso Mill finish Alu + Sealant + Floor cover	± 50	+ Maq. Limpeza Cleaning machine
COR_150_806	Junta sísmica aplicada no selante Sealant applied seismic floor profile	150	350	55	387	Acabamento Alu + Selante + Revestimento piso Mill finish Alu + Sealant + Floor cover	± 75	+ Maq. Limpeza Cleaning machine
COR_200_806	Junta sísmica aplicada no selante Sealant applied seismic floor profile	200	400	55	437	Acabamento Alu + Selante + Revestimento piso Mill finish Alu + Sealant + Floor cover	± 100	+ Maq. Limpeza Cleaning machine
COR_250_806	Junta sísmica aplicada no selante Sealant applied seismic floor profile	250	550	65	587	Acabamento Alu + Selante + Revestimento piso Mill finish Alu + Sealant + Floor cover	± 125	+ Maq. Limpeza Cleaning machine
COR_300_806	Junta sísmica aplicada no selante Sealant applied seismic floor profile	300	600	65	637	Acabamento Alu + Selante + Revestimento piso Mill finish Alu + Sealant + Floor cover	± 150	+ Maq. Limpeza Cleaning machine
COR_350_806	Junta sísmica aplicada no selante Sealant applied seismic floor profile	350	650	65	687	Acabamento Alu + Selante + Revestimento piso Mill finish Alu + Sealant + Floor cover	± 175	+ Maq. Limpeza Cleaning machine
COR_400_806	Junta sísmica aplicada no selante Sealant applied seismic floor profile	400	700	65	737	Acabamento Alu + Selante + Revestimento piso Mill finish Alu + Sealant + Floor cover	± 200	+ Maq. Limpeza Cleaning machine
COR_450_806	Junta sísmica aplicada no selante Sealant applied seismic floor profile	450	750	65	787	Acabamento Alu + Selante + Revestimento piso Mill finish Alu + Sealant + Floor cover	± 200	+ Maq. Limpeza Cleaning machine
COR_500_806	Junta sísmica aplicada no selante Sealant applied seismic floor profile	500	800	65	837	Acabamento Alu + Selante + Revestimento piso Mill finish Alu + Sealant + Floor cover	± 200	+ Maq. Limpeza Cleaning machine

Juntas de dilatação de pavimentos sísmicas de embutir
Flush mounted seismic floor joint profiles



» COR 100_813

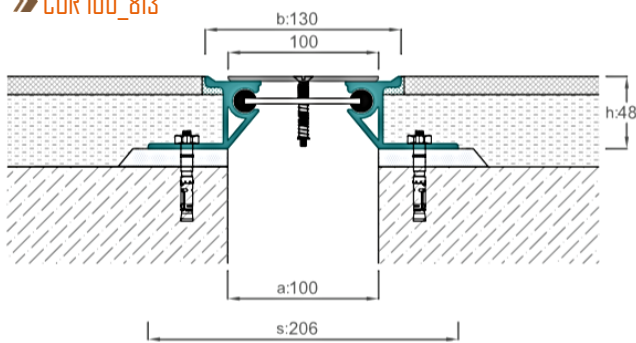

» COR 150_813

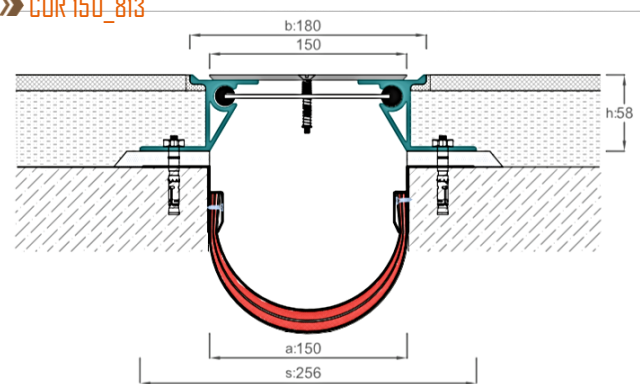

» COR 150K_813

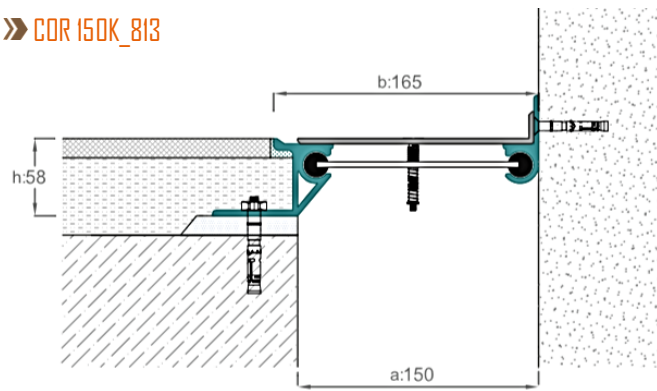

Juntas sísmicas de pavimentos, parede e teto
Seismic floor, wall, ceiling profiles

As juntas higiênicas e decorativas da série COR 813 são compostas pelo perfil inferior de alumínio e pela placa superior de aço inoxidável. Especialmente usada em estações de metro, centros comerciais e hospitais.

Hygienic and decorative COR 813 series profiles are composed of aluminum bottom profile and stainless-steel top plate. Especially used in metro stations, shopping centers and hospitals.



REF	DESCRIÇÃO DESCRIPTION	LARGURA DA JUNTA (a) mm JOINT WIDTH	SUPERFÍCIE VISÍVEL (b) mm SURFACE VISIBLE	ALTURA (h) mm PROFILE HEIGHT	LARGURA (s) mm TOTAL WIDTH	SUPERFÍCIE SURFACE	CAPACIDADE MOVIMENTO MOVEMENT CAPACITY	CAPACIDADE CARGA LOAD CAPACITY
COR_100_813	Superfície superior em aço inoxidável + junta de pavimento sísmico Stainless steel top surface + Seismic floor profile	100	130	48	206	Acabamento Alu + Aço inoxidável Mill finish Alu + Stainless steel	+40/-50	3,5 Ton
COR_150_813	Superfície superior em aço inoxidável + junta de pavimento sísmico Stainless steel top surface + Seismic floor profile	150	180	58	256	Acabamento Alu + Aço inoxidável Mill finish Alu + Stainless steel	+60/-60	3,5 Ton
COR_200_813	Superfície superior em aço inoxidável + junta de pavimento sísmico Stainless steel top surface + Seismic floor profile	200	230	58	306	Acabamento Alu + Aço inoxidável Mill finish Alu + Stainless steel	+60/-100	3,5 Ton
COR_250_813	Superfície superior em aço inoxidável + junta de pavimento sísmico Stainless steel top surface + Seismic floor profile	250	280	58	356	Acabamento Alu + Aço inoxidável Mill finish Alu + Stainless steel	+60/-125	+ Maq. Limpeza Cleaning machine
COR_300_813	Superfície superior em aço inoxidável + junta de pavimento sísmico Stainless steel top surface + Seismic floor profile	300	330	58	406	Acabamento Alu + Aço inoxidável Mill finish Alu + Stainless steel	+60/-150	+ Maq. Limpeza Cleaning machine

Juntas de dilatação de pavimentos sísmicas de embutir
 Flush mounted seismic floor joint profiles

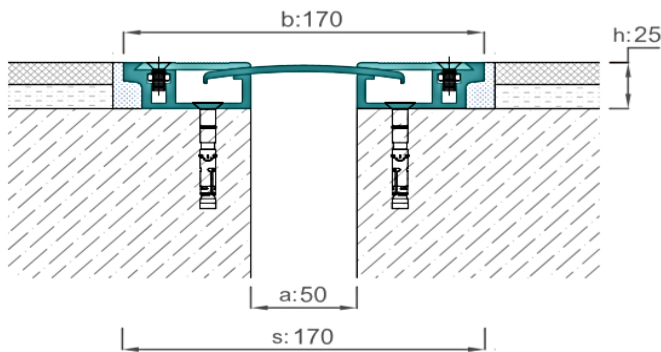

» COR 050_851

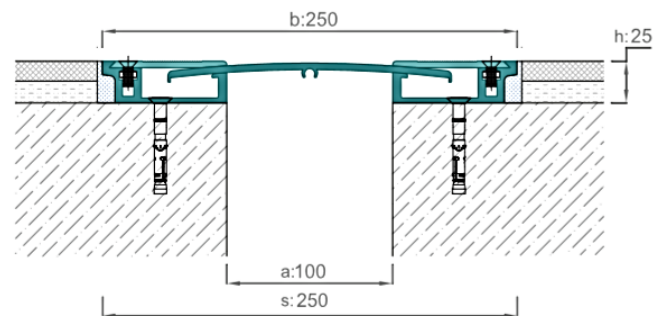

» COR 100_851

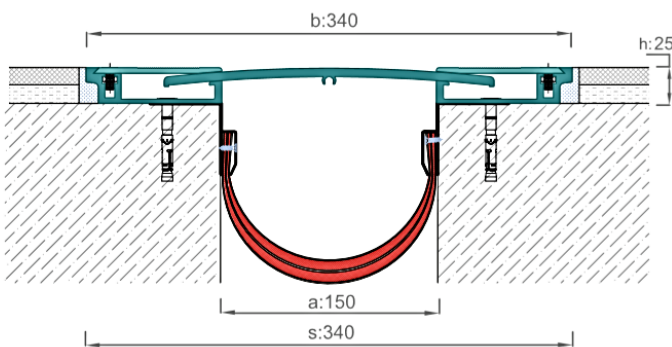

» COR 150_851

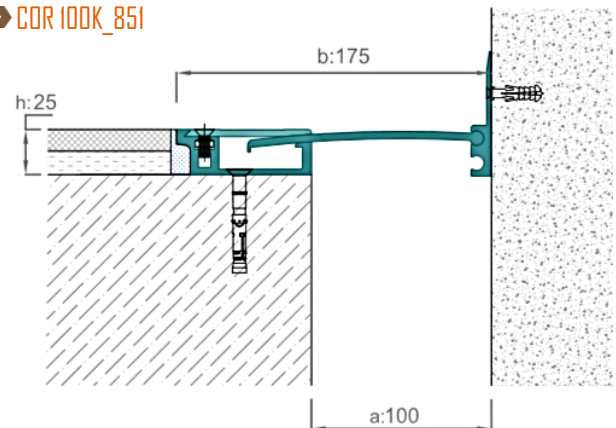

» COR 100K_851

 Juntas sísmicas de pavimentos, parede e teto
 Seismic floor, wall, Ceiling profiles

As juntas de dilatação de pavimento sísmicas têm características de alta capacidade de movimento e resistentes a cargas pesadas com superfície superior totalmente em alumínio.
 Seismic floor expansion joint profiles have the features of high movement capacity and resistant to heavy loads with completely aluminum top surface.



REF	DESCRIÇÃO DESCRIPTION	LARGURA DA JUNTA (a) mm JOINT WIDTH	SUPERFÍCIE VISÍVEL (b) mm SURFACE VISIBLE	ALTURA (h) mm PROFILE HEIGHT	LARGURA (s) mm TOTAL WIDTH	SUPERFÍCIE SURFACE	CAPACIDADE MOVIMENTO MOVEMENT CAPACITY	CAPACIDADE CARGA LOAD CAPACITY
COR_050_851	Junta sísmica de pavimento com superfície de alumínio Aluminum top surfaced seismic floor profile	50	170	25	170	Acabamento Alumínio Mill finish Aluminum	± 25	3,5 Ton
COR_100_851	Junta sísmica de pavimento com superfície de alumínio Aluminum top surfaced seismic floor profile	100	250	25	250	Acabamento Alumínio Mill finish Aluminum	+50/-30	2,5 Ton
COR_101_851	Junta sísmica de pavimento com superfície de alumínio Aluminum top surfaced seismic floor profile	100	290	25	290	Acabamento Alumínio Mill finish Aluminum	± 60	2,5 Ton
COR_125_851	Junta sísmica de pavimento com superfície de alumínio Aluminum top surfaced seismic floor profile	125	330	25	330	Acabamento Alumínio Mill finish Aluminum	± 60	2,5 Ton
COR_150_851	Junta sísmica de pavimento com superfície de alumínio Aluminum top surfaced seismic floor profile	150	340	25	340	Acabamento Alumínio Mill finish Aluminum	± 60	2,5 Ton
COR_200_851	Junta sísmica de pavimento com superfície de alumínio Aluminum top surfaced seismic floor profile	200	390	25	390	Acabamento Alumínio Mill finish Aluminum	± 60	+ 1,5 Ton



» COR 100_932

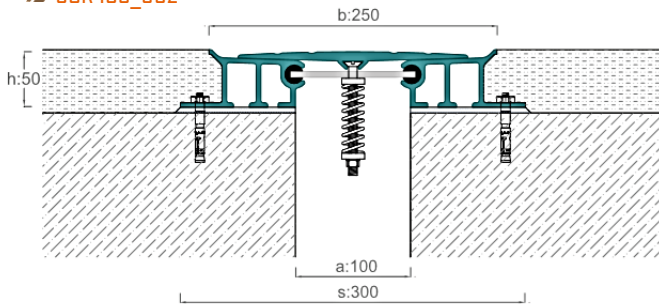

» COR 150_932

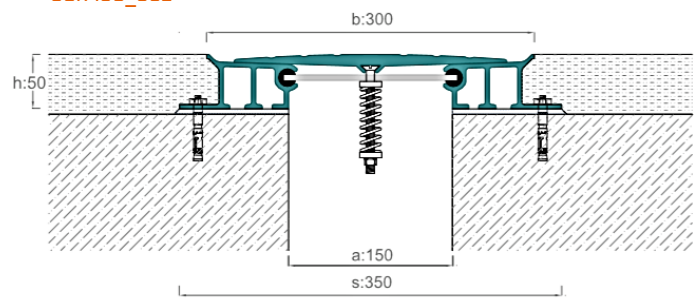

» COR 100K_932

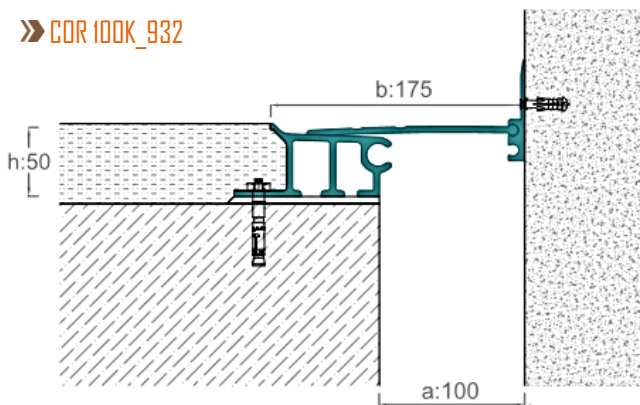

» COR 150K_932

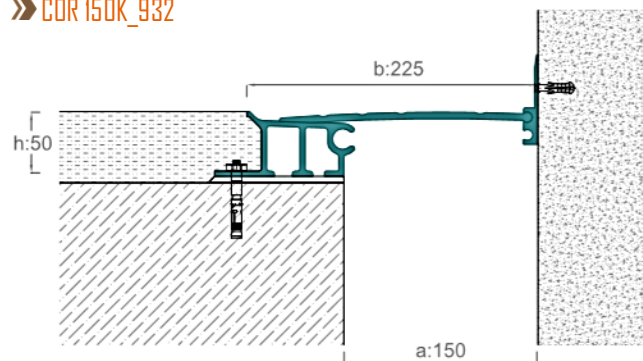

Juntas sísmicas de pavimentos, parede e teto
Seismic floor, wall, Ceiling profiles

A série COR 932 é composta por uma superfície superior de alumínio grande e tem capacidade para se mover em direções tridimensionais.

COR 932 series are composed of large Aluminum top surface and have the capacity to move in 3 dimensional directions.



REF	DESCRIÇÃO DESCRIPTION	LARGURA DA JUNTA (a) mm JOINT WIDTH	SUPERFÍCIE VISÍVEL (b) mm SURFACE VISIBLE	ALTURA (h) mm PROFILE HEIGHT	LARGURA (s) mm TOTAL WIDTH	SUPERFÍCIE SURFACE	CAPACIDADE MOVIMENTO MOVEMENT CAPACITY	CAPACIDADE CARGA LOAD CAPACITY
COR_100_932	Juntas sísmicas de alta capacidade de carga High load capacity seismic profiles	100	250	50	300	Acabamento Alumínio Mill finish Aluminum	± 50	15 Ton
COR_150_932	Juntas sísmicas de alta capacidade de carga High load capacity seismic profiles	150	300	50	350	Acabamento Alumínio Mill finish Aluminum	± 75	15 Ton
COR_200_932	Juntas sísmicas de alta capacidade de carga High load capacity seismic profiles	200	350	50	400	Acabamento Alumínio Mill finish Aluminum	± 100	9 Ton

Juntas de dilatação de pavimento sísmicas de embutir
Flush mounted seismic floor joint profiles

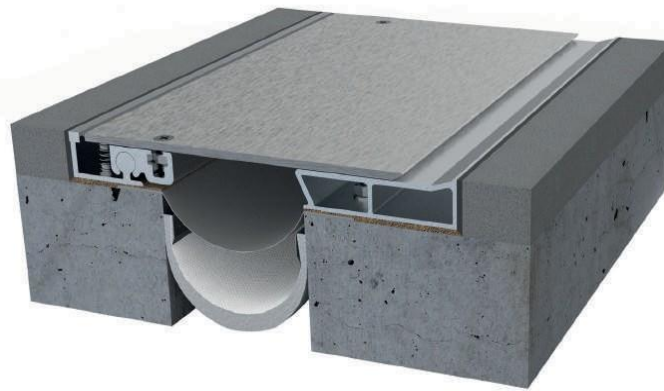

» COR 150_931

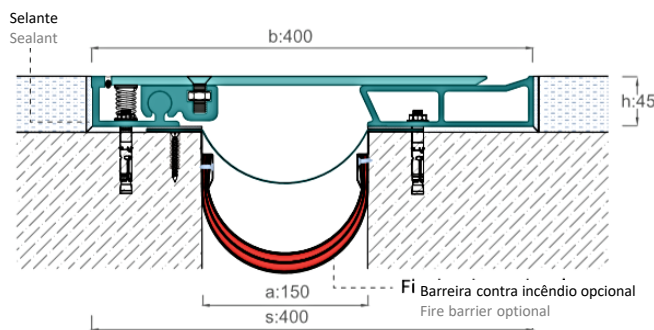

» COR 200_931

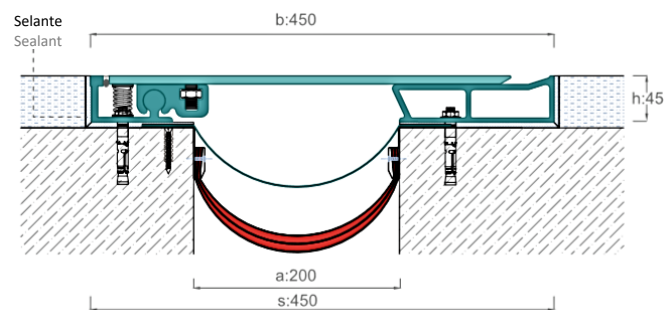

» COR 150K_931

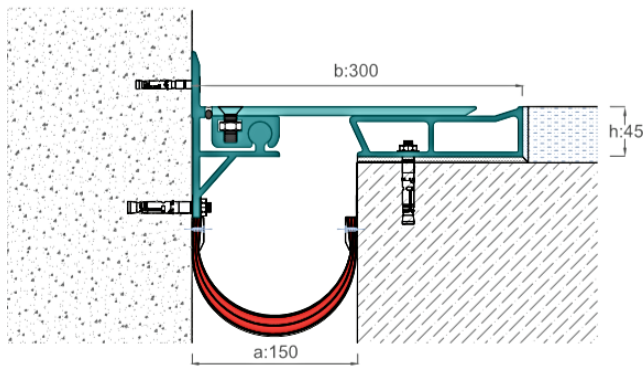

» COR 200K_931

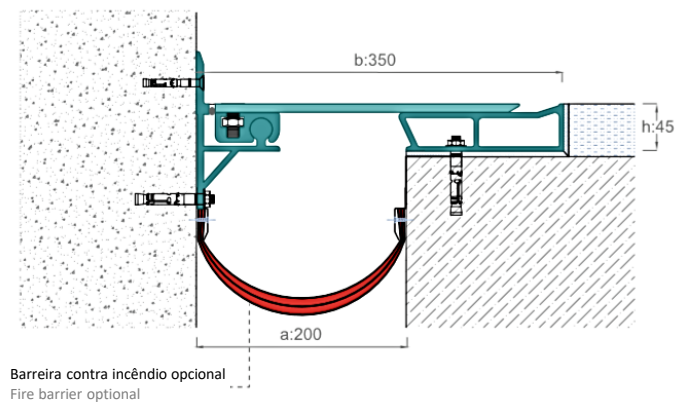

Juntas sísmicas de pavimentos, parede e teto
Seismic floor, wall, ceiling profiles

As juntas de pavimento embutidas são articuladas de um lado e têm opções alternativas de superfície superior feitas de aço galvanizado e alumínio.

Flush mounted floor profiles are one sided articulated and have alternative top surface options made of galvanized steel and aluminum.



REF	DESCRIÇÃO DESCRIPTION	LARGURA DA JUNTA (a) mm JOINT WIDTH	SUPERFÍCIE VISÍVEL (b) mm SURFACE VISIBLE	ALTURA (h) mm PROFILE HEIGHT	LARGURA (s) mm TOTAL WIDTH	SUPERFÍCIE SURFACE	CAPACIDADE MOVIMENTO MOVEMENT CAPACITY	CAPACIDADE CARGA LOAD CAPACITY
COR_050_931	Adequado para estruturas industriais e parques de estacionamento Suitable for industrial structures and car parks	50	300	45	300	Acabamento Alumínio Mill finish Aluminum	± 25	30 Ton 6,5 Ton
COR_100_931	Adequado para estruturas industriais e parques de estacionamento Suitable for industrial structures and car parks	100	350	45	350	Acabamento Alumínio Mill finish Aluminum	± 50	30 Ton 6,5 Ton
COR_150_931	Adequado para estruturas industriais e parques de estacionamento Suitable for industrial structures and car parks	150	400	45	400	Acabamento Alumínio Mill finish Aluminum	± 75	30 Ton 6,5 Ton
COR_200_931	Adequado para estruturas industriais e parques de estacionamento Suitable for industrial structures and car parks	200	450	45	450	Acabamento Alumínio Mill finish Aluminum	± 100	15 Ton 3,5 Ton
COR_250_931	Adequado para estruturas industriais e parques de estacionamento Suitable for industrial structures and car parks	250	550	45	550	Acabamento Alu + Aço galvanizado Mill finish Alu + Galvanized steel	± 100	15 Ton 3,5 Ton
COR_300_931	Adequado para estruturas industriais e parques de estacionamento Suitable for industrial structures and car parks	300	600	45	600	Acabamento Alu + Aço galvanizado Mill finish Alu + Galvanized steel	± 100	15 Ton 3,5 Ton

Juntas de dilatação de pavimento sísmico de embutir
 Flush mounted seismic floor joint profiles

>> COR 500_961

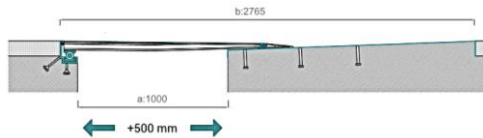
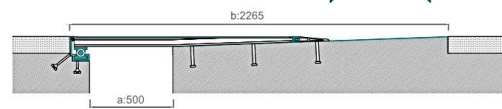
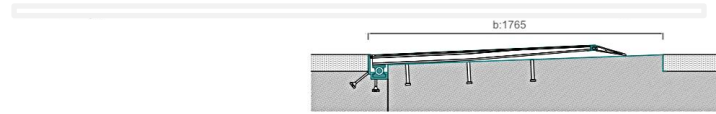
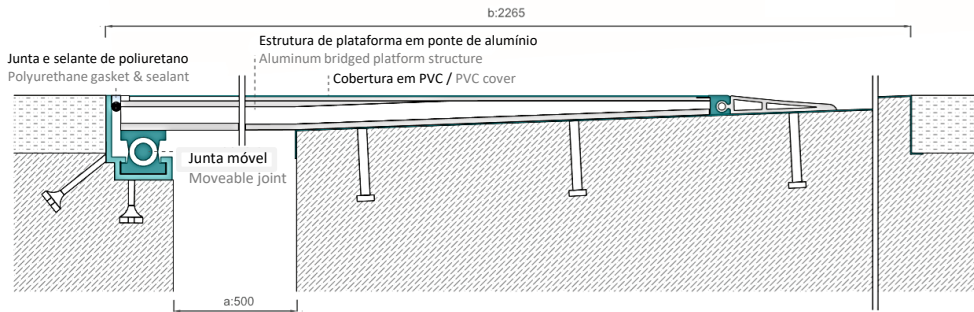
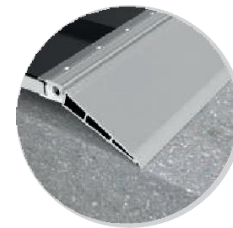
 Juntas sísmicas de pavimentos, parede e teto
 Seismic floor, wall, ceiling profiles

Junta de dilatação articulada são projetados para grandes folgas com alta capacidade de movimento. Pode ser visto frequentemente em edifícios sísmicos isolados. Adequado para veículos, rampas e estacionamentos.

Jointed expansion joint profiles are designed for large gaps with high movement capacity. Can often be seen in seismic isolated buildings. Suitable for vehicles, ramps and car parks.

REF	DESCRIÇÃO DESCRIPTION	LARGURA DA JUNTA (a) mm JOINT WIDTH	SUPERFÍCIE VISÍVEL (b) mm SURFACE VISIBLE	ALTURA (h) mm PROFILE HEIGHT	LARGURA (s) mm TOTAL WIDTH	SUPERFÍCIE SURFACE	CAPACIDADE MOVIMENTO MOVEMENT CAPACITY	CAPACIDADE CARGA LOAD CAPACITY
COR_400_961	Alta capacidade de movimentação para grandes juntas High moving capacity for large gaps	400	2065	65	2065	Alumínio + Aço galvanizado + PVC Aluminum + Galvanized steel + PVC	± 400	9 Ton
COR_500_961	Alta capacidade de movimentação para grandes juntas High moving capacity for large gaps	500	2265	65	2265	Alumínio + Aço galvanizado + PVC Aluminum + Galvanized steel + PVC	± 500	9 Ton
COR_600_961	Alta capacidade de movimentação para grandes juntas High moving capacity for large gaps	600	2465	65	2465	Alumínio + Aço galvanizado + PVC Aluminum + Galvanized steel + PVC	± 600	9 Ton
COR_700_961	Alta capacidade de movimentação para grandes juntas High moving capacity for large gaps	700	2665	65	2665	Alumínio + Aço galvanizado + PVC Aluminum + Galvanized steel + PVC	± 700	9 Ton
COR_400_971	Alta capacidade de movimentação para grandes juntas High moving capacity for large gaps	400	1274	65	1274	Alumínio + Aço galvanizado + PVC Aluminum + Galvanized steel + PVC	± 400	+ Tráf. maca Stretcher traf.
COR_500_971	Alta capacidade de movimentação para grandes juntas High moving capacity for large gaps	500	1474	65	1474	Alumínio + Aço galvanizado + PVC Aluminum + Galvanized steel + PVC	± 500	+ Tráf. maca Stretcher traf.
COR_600_971	Alta capacidade de movimentação para grandes juntas High moving capacity for large gaps	600	1674	65	1674	Alumínio + Aço galvanizado + PVC Aluminum + Galvanized steel + PVC	± 600	+ Tráf. maca Stretcher traf.
COR_700_971	Alta capacidade de movimentação para grandes juntas High moving capacity for large gaps	700	1874	65	1874	Alumínio + Aço galvanizado + PVC Aluminum + Galvanized steel + PVC	± 700	+ Tráf. maca Stretcher traf.
COR_750_971	Alta capacidade de movimentação para grandes juntas High moving capacity for large gaps	750	1924	65	1924	Alumínio + Aço galvanizado + PVC Aluminum + Galvanized steel + PVC	± 300	+ Tráf. maca Stretcher traf.



» COR 750_971

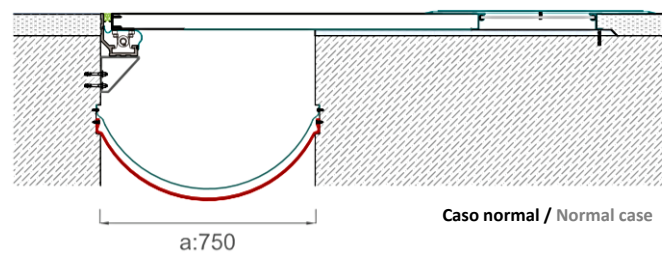
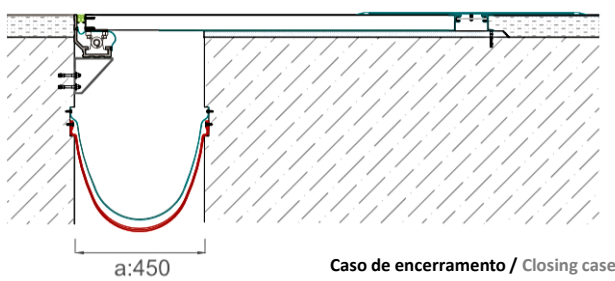
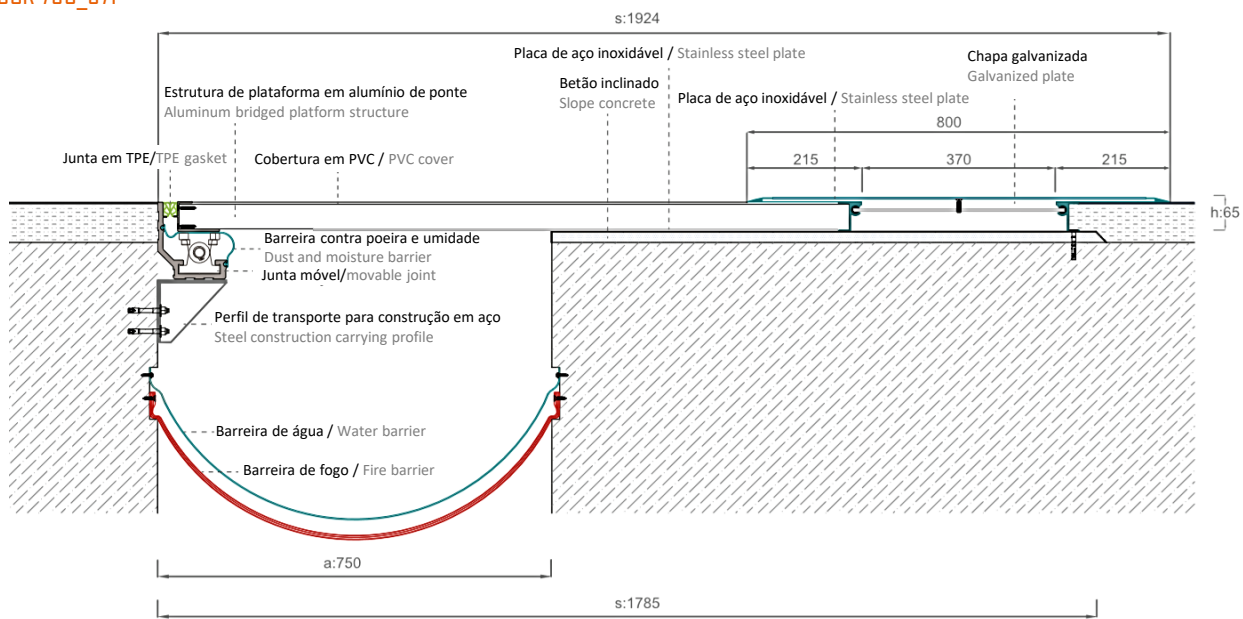

← -300 mm →

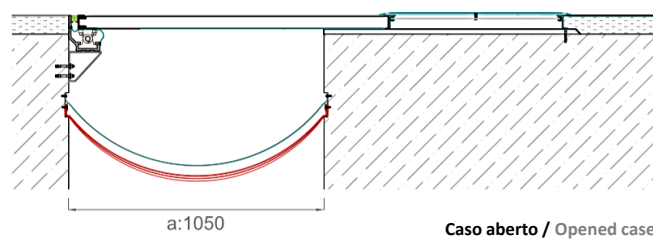

← +300 mm →

Juntas sísmicas de pavimentos, parede e teto
Seismic floor, wall, Ceiling profiles

Juntas sísmicas embutidas para montagem em parede e teto
Flush mounted seismic wall and ceiling joint profiles

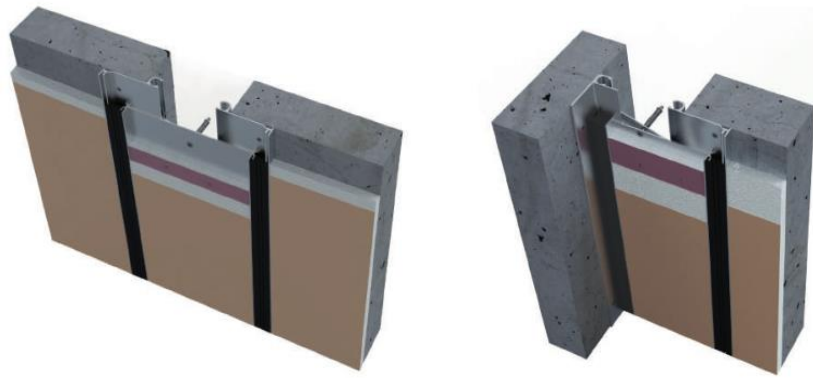

» COR 100_232

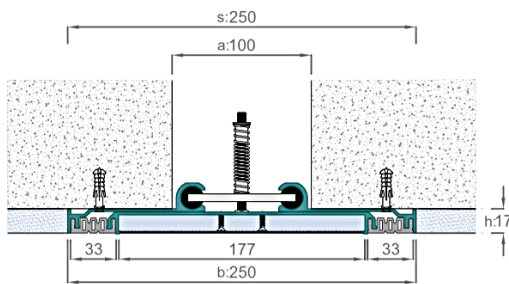

» COR 150_232

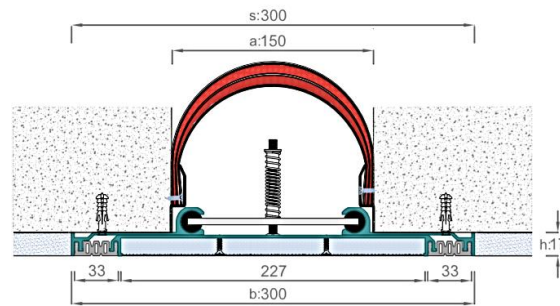

» COR 150K_232

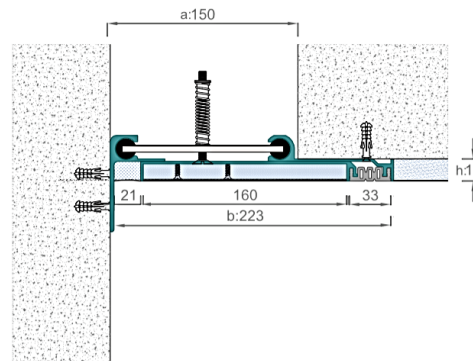

Juntas sísmicas de pavimentos, parede e teto
Seismic floor, wall, ceiling profiles



COR 232 são as soluções de parede e teto da série de juntas de dilatação sísmicas COR 802.
COR 232 are the wall and ceiling solutions of COR 802 seismic expansion joint series.

REF	DESCRIÇÃO DESCRIPTION	LARGURA DA JUNTA (a) mm JOINT WIDTH	SUPERFÍCIE VISÍVEL (b) mm SURFACE VISIBLE	ALTURA PERFIL (h) mm PROFILE HEIGHT	LARGURA DA TOTAL (s) mm TOTAL WIDTH	SUPERFÍCIE SURFACE	CAPACIDADE MOVIMENTO MOVEMENT CAPACITY
COR_100_232	Adequado para betonilha, gesso cartonado etc/ vedação Suitable with screed, dry wall and etc / gasketed	100	250	17	250	Acabamento Alu + TPE + tampa Mill finish ALU + TPE + Cover	± 50
COR_150_232	Adequado para betonilha, gesso cartonado etc/ vedação Suitable with screed, dry wall and etc / gasketed	150	300	17	300	Acabamento Alu + TPE + tampa Mill finish ALU + TPE + Cover	± 70
COR_200_232	Adequado para betonilha, gesso cartonado etc/ vedação Suitable with screed, dry wall and etc / gasketed	200	400	20	400	Acabamento Alu + TPE + tampa Mill finish ALU + TPE + Cover	+100/-80
COR_250_232	Adequado para betonilha, gesso cartonado etc/ vedação Suitable with screed, dry wall and etc / gasketed	250	450	20	450	Acabamento Alu + TPE + tampa Mill finish ALU + TPE + Cover	+125/-80
COR_300_232	Adequado para betonilha, gesso cartonado etc/ vedação Suitable with screed, dry wall and etc / gasketed	300	600	20	600	Acabamento Alu + TPE + tampa Mill finish ALU + TPE + Cover	± 150
COR_350_212	Adequado para betonilha, gesso cartonado etc/ vedação Suitable with screed, dry wall and etc / gasketed	350	650	20	650	Acabamento Alu + TPE + tampa Mill finish ALU + TPE + Cover	± 175
COR_400_232	Adequado para betonilha, gesso cartonado etc/ vedação Suitable with screed, dry wall and etc / gasketed	400	700	20	700	Acabamento Alu + TPE + tampa Mill finish ALU + TPE + Cover	+175/-200
COR_450_232	Adequado para betonilha, gesso cartonado etc/ vedação Suitable with screed, dry wall and etc / gasketed	450	750	20	750	Acabamento Alu + TPE + tampa Mill finish ALU + TPE + Cover	+175/-225
COR_500_232	Adequado para betonilha, gesso cartonado etc/ vedação Suitable with screed, dry wall and etc / gasketed	500	800	20	800	Acabamento Alu + TPE + tampa Mill finish ALU + TPE + Cover	± 25

Juntas sísmicas embutidas para montagem em parede e teto
Flush mounted seismic wall and ceiling joint profiles

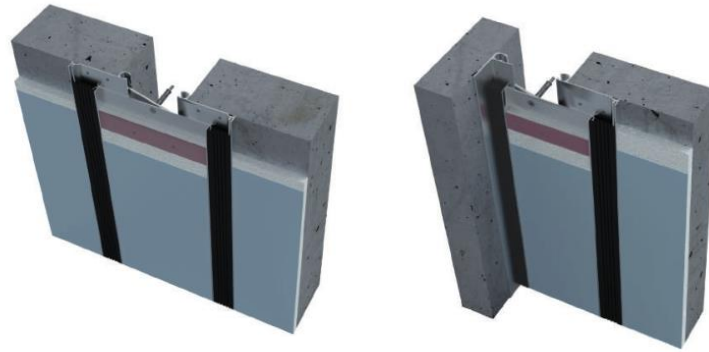

» COR 100_233

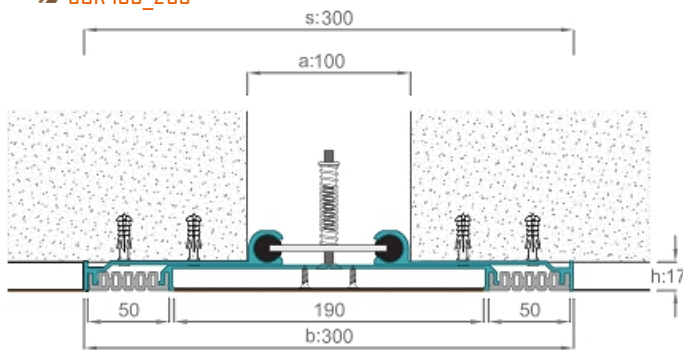

» COR 150_233

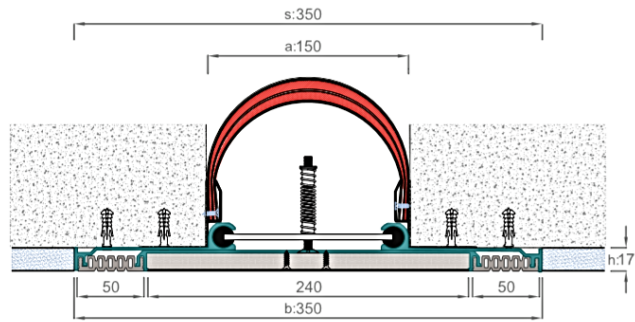

» COR 150K_233

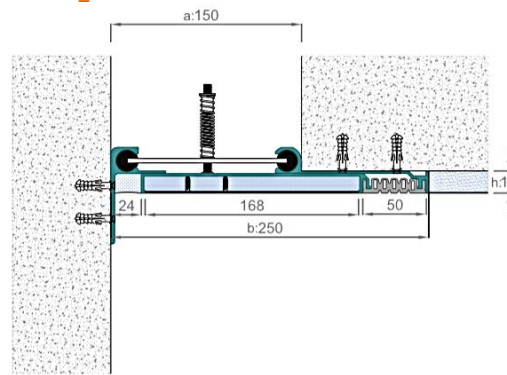

Juntas sísmicas de pavimentos, parede e teto
Seismic floor, wall, ceiling profiles

As juntas de parede e teto COR 233 são aplicáveis aos projetos em que as juntas sísmicas de pavimento COR 803 foram utilizadas.

COR 233 wall and ceiling series are applicable to the projects where COR 803 seismic floor profiles have been used.



REF	DESCRIÇÃO DESCRIPTION	LARGURA DA JUNTA (a) mm JOINT WIDTH	SUPERFÍCIE VISÍVEL (b) mm SURFACE VISIBLE	ALTURA PERFIL (h) mm PROFILE HEIGHT	LARGURA DA TOTAL (s) mm TOTAL WIDTH	SUPERFÍCIE SURFACE	CAPACIDADE MOVIMENTO MOVEMENT CAPACITY
COR_100_233	Adequado para betonilha, gesso cartonado etc/ vedação Suitable with screed, dry wall and etc / gasketed	100	300	17	300	Acabamento Alu + TPE + tampa Mill finish ALU + TPE + Cover	± 50
COR_150_233	Adequado para betonilha, gesso cartonado etc/ vedação Suitable with screed, dry wall and etc / gasketed	150	350	17	350	Acabamento Alu + TPE + tampa Mill finish ALU + TPE + Cover	± 75
COR_200_233	Adequado para betonilha, gesso cartonado etc/ vedação Suitable with screed, dry wall and etc / gasketed	200	400	20	400	Acabamento Alu + TPE + tampa Mill finish ALU + TPE + Cover	± 100
COR_250_233	Adequado para betonilha, gesso cartonado etc/ vedação Suitable with screed, dry wall and etc / gasketed	250	450	20	450	Acabamento Alu + TPE + tampa Mill finish ALU + TPE + Cover	± 125
COR_300_233	Adequado para betonilha, gesso cartonado etc/ vedação Suitable with screed, dry wall and etc / gasketed	300	500	20	500	Acabamento Alu + TPE + tampa Mill finish ALU + TPE + Cover	± 125

Juntas sísmicas embutidas para montagem em parede e teto
Flush mounted seismic wall and ceiling joint profiles



» COR 100_234

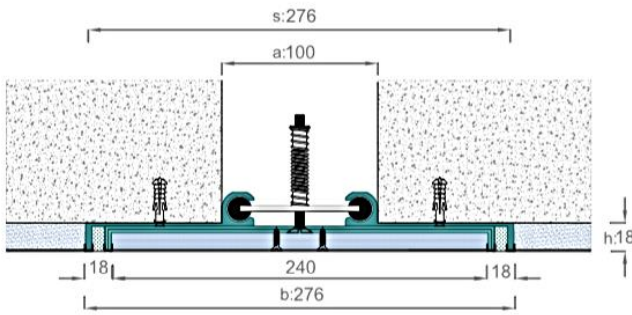

» COR 150_234

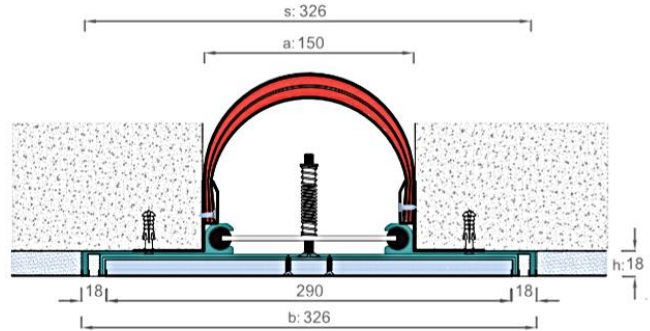

» COR 150K_234

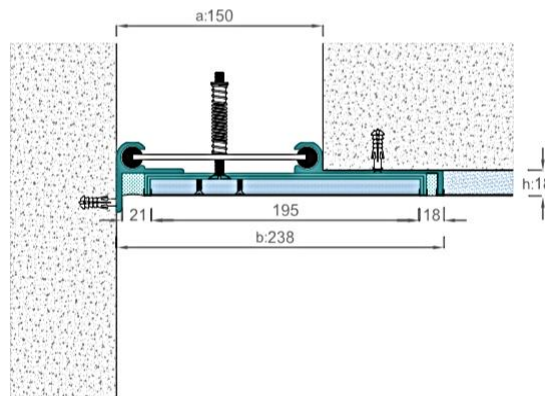

Juntas sísmicas de pavimentos, parede e teto
Seismic floor, wall, ceiling profiles

As juntas sísmicas COR 234 são compatíveis com as juntas de dilatação de pavimento da série COR 804.

COR 234 seismic series are compatible with COR 804 series floor expansion joint profiles.



REF	DESCRIÇÃO DESCRIPTION	LARGURA DA JUNTA (a) mm JOINT WIDTH	SUPERFÍCIE VISÍVEL (b) mm SURFACE VISIBLE	ALTURA PERFIL (h) mm PROFILE HEIGHT	LARGURA DA TOTAL (s) mm TOTAL WIDTH	SUPERFÍCIE SURFACE	CAPACIDADE MOVIMENTO MOVEMENT CAPACITY
COR_100_234	Adequado para cerâmica, gesso cartonado / Superfície em Aço inoxidável Suitable with ceramic, dry wall and etc / Stainless steel surface	100	276	18	276	Aço inoxidável + Selante + tampa Stainless steel + Sealant + Cover	± 50
COR_150_234	Adequado para cerâmica, gesso cartonado / Superfície em Aço inoxidável Suitable with ceramic, dry wall and etc / Stainless steel surface	150	326	18	326	Aço inoxidável + Selante + tampa Stainless steel + Sealant + Cover	± 75
COR_200_234	Adequado para cerâmica, gesso cartonado / Superfície em Aço inoxidável Suitable with ceramic, dry wall and etc / Stainless steel surface	200	376	18	376	Aço inoxidável + Selante + tampa Stainless steel + Sealant + Cover	± 75
COR_250_234	Adequado para cerâmica, gesso cartonado / Superfície em Aço inoxidável Suitable with ceramic, dry wall and etc / Stainless steel surface	250	426	18	426	Aço inoxidável + Selante + tampa Stainless steel + Sealant + Cover	± 75
COR_300_234	Adequado para cerâmica, gesso cartonado / Superfície em Aço inoxidável Suitable with ceramic, dry wall and etc / Stainless steel surface	300	476	18	476	Aço inoxidável + Selante + tampa Stainless steel + Sealant + Cover	± 75

Juntas sísmicas embutidas para montagem em parede e teto
Flush mounted seismic wall and ceiling joint profiles



» COR 100_236

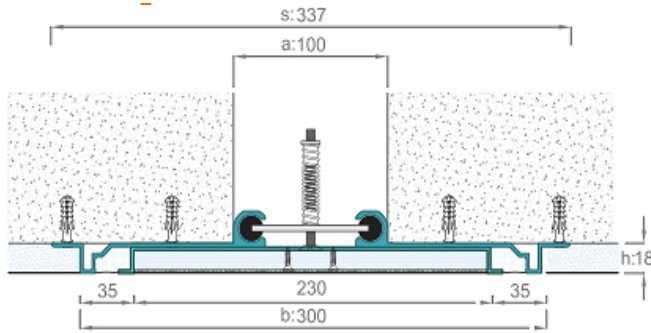

» COR 150_236

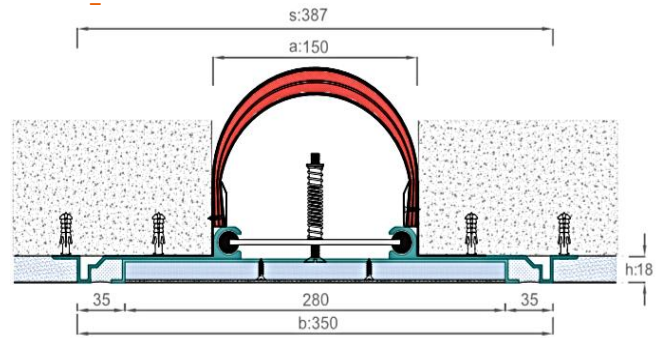

» COR 150K_236

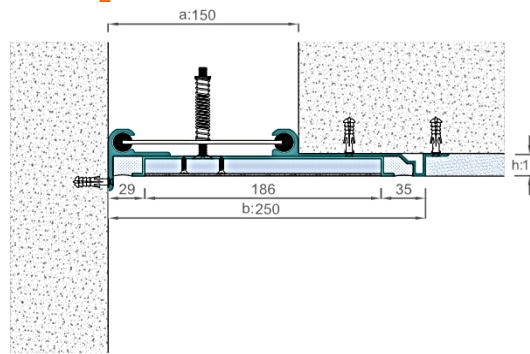

Juntas sísmicas de pavimentos, parede e teto
Seismic floor, wall, ceiling profiles

As juntas de parede e teto COR 236 são adequadas para locais onde foram utilizadas juntas de dilatação sísmicas de pavimento COR 806.

COR 236 wall and ceiling series are suitable to places where COR 806 seismic floor expansion joint profiles have been used.



REF	DESCRIÇÃO DESCRIPTION	LARGURA DA JUNTA (a) mm JOINT WIDTH	SUPERFÍCIE VISÍVEL (b) mm SURFACE VISIBLE	ALTURA PERFIL (h) mm PROFILE HEIGHT	LARGURA DA TOTAL (s) mm TOTAL WIDTH	SUPERFÍCIE SURFACE	CAPACIDADE MOVIMENTO MOVEMENT CAPACITY
COR_100_236	Adequado com betonilha de cerâmica, gesso cartonado / Aplicação de selante Suitable with screed ceramic, dry wall and etc / Sealant application	100	300	18	337	Acabamento Alu + Selante + tampa Mill finish ALU + Sealant + Cover	± 50
COR_150_236	Adequado com betonilha de cerâmica, gesso cartonado / Aplicação de selante Suitable with screed ceramic, dry wall and etc / Sealant application	150	350	18	387	Acabamento Alu + Selante + tampa Mill finish ALU + Sealant + Cover	± 70
COR_200_236	Adequado com betonilha de cerâmica, gesso cartonado / Aplicação de selante Suitable with screed ceramic, dry wall and etc / Sealant application	200	400	18	437	Acabamento Alu + Selante + tampa Mill finish ALU + Sealant + Cover	± 100
COR_250_236	Adequado com betonilha de cerâmica, gesso cartonado / Aplicação de selante Suitable with screed ceramic, dry wall and etc / Sealant application	250	550	18	587	Acabamento Alu + Selante + tampa Mill finish ALU + Sealant + Cover	± 125
COR_300_236	Adequado com betonilha de cerâmica, gesso cartonado / Aplicação de selante Suitable with screed ceramic, dry wall and etc / Sealant application	300	600	18	637	Acabamento Alu + Selante + tampa Mill finish ALU + Sealant + Cover	± 150
COR_350_236	Adequado com betonilha de cerâmica, gesso cartonado / Aplicação de selante Suitable with screed ceramic, dry wall and etc / Sealant application	350	650	18	687	Acabamento Alu + Selante + tampa Mill finish ALU + Sealant + Cover	± 175
COR_400_236	Adequado com betonilha de cerâmica, gesso cartonado / Aplicação de selante Suitable with screed ceramic, dry wall and etc / Sealant application	400	700	18	737	Acabamento Alu + Selante + tampa Mill finish ALU + Sealant + Cover	± 200
COR_450_236	Adequado com betonilha de cerâmica, gesso cartonado / Aplicação de selante Suitable with screed ceramic, dry wall and etc / Sealant application	450	750	18	787	Acabamento Alu + Selante + tampa Mill finish ALU + Sealant + Cover	± 200
COR_500_236	Adequado com betonilha de cerâmica, gesso cartonado / Aplicação de selante Suitable with screed ceramic, dry wall and etc / Sealant application	500	800	18	837	Acabamento Alu + Selante + tampa Mill finish ALU + Sealant + Cover	± 200

Juntas sísmicas embutidas para montagem em parede e teto
 Flush mounted seismic wall and ceiling joint profiles

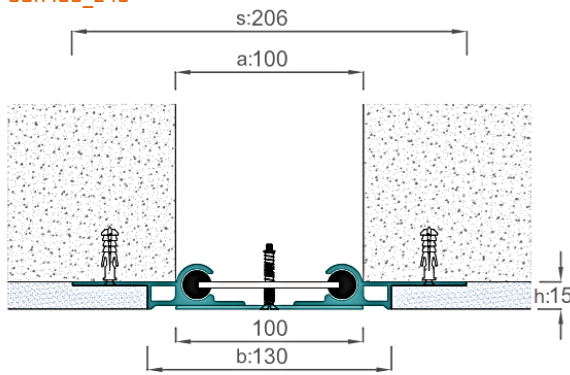

» COR 100_243

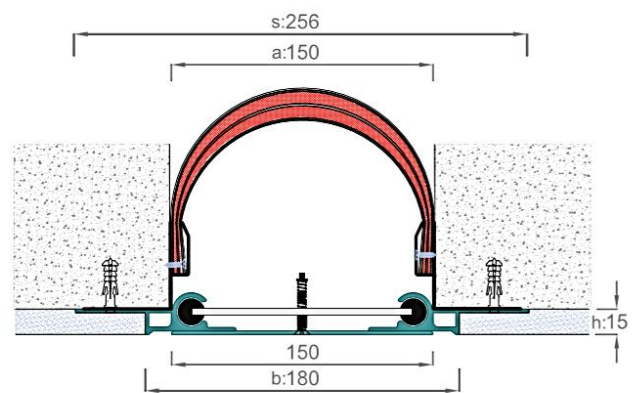

» COR 150_243

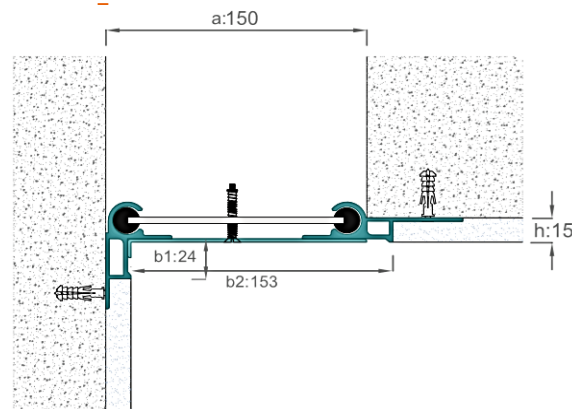

» COR 150K_243



 Juntas sísmicas de
 pavimentos, parede e teto
 Seismic floor, wall, ceiling
 profiles

A junta COR 243 é preferida pela sua superfície superior brilhante, onde a junta COR 813 foi usada no chão.
 COR 243 series are preferred with its shiny top surface where COR 813 series has been used on the floor.

REF	DESCRIÇÃO DESCRIPTION	LARGURA DA JUNTA (a) mm JOINT WIDTH	SUPERFÍCIE VISÍVEL (b) mm SURFACE VISIBLE	ALTURA PERFIL (h) mm PROFILE HEIGHT	LARGURA DA TOTAL (s) mm TOTAL WIDTH	SUPERFÍCIE SURFACE	CAPACIDADE MOVIMENTO MOVEMENT CAPACITY
COR_100_243	Adequado para betonilha, gesso cartonado / Superfície superior em aço inoxidável Suitable with screed, dry wall and etc / Stainless steel top surface	100	130	15	206	Acabamento Alu + Aço inoxidável Mill finish ALU + Stainless steel	+40/-50
COR_150_243	Adequado para betonilha, gesso cartonado / Superfície superior em aço inoxidável Suitable with screed, dry wall and etc / Stainless steel top surface	150	180	15	256	Acabamento Alu + Aço inoxidável Mill finish ALU + Stainless steel	+60/-75
COR_200_243	Adequado para betonilha, gesso cartonado / Superfície superior em aço inoxidável Suitable with screed, dry wall and etc / Stainless steel top surface	200	230	15	306	Acabamento Alu + Aço inoxidável Mill finish ALU + Stainless steel	+60/-100
COR_250_243	Adequado para betonilha, gesso cartonado / Superfície superior em aço inoxidável Suitable with screed, dry wall and etc / Stainless steel top surface	250	280	15	356	Acabamento Alu + Aço inoxidável Mill finish ALU + Stainless steel	+60/-125
COR_300_243	Adequado para betonilha, gesso cartonado / Superfície superior em aço inoxidável Suitable with screed, dry wall and etc / Stainless steel top surface	300	330	15	406	Acabamento Alu + Aço inoxidável Mill finish ALU + Stainless steel	+60/-150

Juntas sísmicas de parede e teto montadas a superfície
 Surface mounted seismic wall and ceiling expansion joint profiles

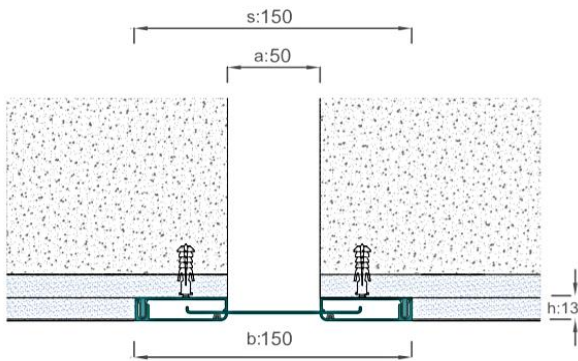
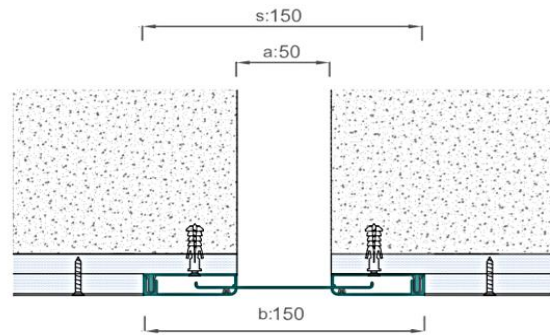

»» COR 050_281

 »» COR 050_281 Alternativa de aplicação de parede seca em dupla camada
 Double layered dry wall application alternative

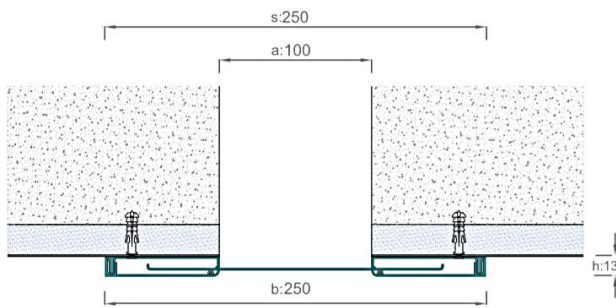
»» COR 100_281

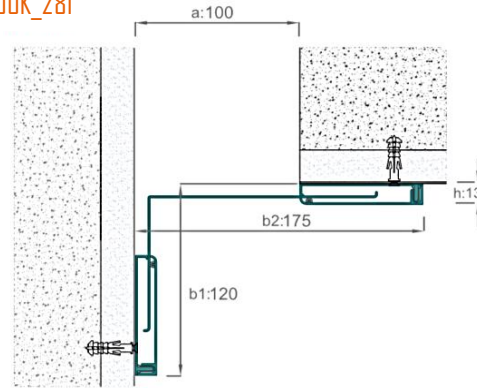

»» COR 100K_281

 Juntas sísmicas de pavimentos, parede e teto
 Seismic floor, wall, ceiling profiles

As juntas de dilatação de parede e teto são adequadas para todos os tipos de revestimentos de paredes com a superfície superior de alumínio especial. Pode ser entregue com revestimento anodizado ou em pó. Adaptável com a maioria das juntas de dilatação de pavimento.

Wall and ceiling profiles are suitable for all kinds of wall coverings with the special aluminum top surface. Can be delivered by anodized or powder coated. Adoptable with most types of floor expansion joint profiles.



REF	DESCRIÇÃO DESCRIPTION	LARGURA DA JUNTA (a) mm JOINT WIDTH	SUPERFÍCIE VISÍVEL (b) mm SURFACE VISIBLE	ALTURA PERFIL (h) mm PROFILE HEIGHT	LARGURA DA TOTAL (s) mm TOTAL WIDTH	SUPERFÍCIE SURFACE	CAPACIDADE MOVIMENTO MOVEMENT CAPACITY
COR_050_281	Superfície superior de alumínio, junta sísmica de parede e teto anodizado Aluminum top surface, anodized seismic wall and ceiling profile	50	150	13	150	Alumínio anodizado Aluminum anodised	± 40
COR_100_281	Superfície superior de alumínio, junta sísmica de parede e teto anodizado Aluminum top surface, anodized seismic wall and ceiling profile	100	250	13	250	Alumínio anodizado Aluminum anodised	± 50
COR_150_281	Superfície superior de alumínio, junta sísmica de parede e teto anodizado Aluminum top surface, anodized seismic wall and ceiling profile	150	300	13	300	Alumínio anodizado Aluminum anodised	± 65
COR_200_281	Superfície superior de alumínio, junta sísmica de parede e teto anodizado Aluminum top surface, anodized seismic wall and ceiling profile	200	350	13	350	Alumínio anodizado Aluminum anodised	± 65
COR_250_281	Superfície superior de alumínio, junta sísmica de parede e teto anodizado Aluminum top surface, anodized seismic wall and ceiling profile	250	400	13	400	Alumínio anodizado Aluminum anodised	± 65
COR_300_281	Superfície superior de alumínio, junta sísmica de parede e teto anodizado Aluminum top surface, anodized seismic wall and ceiling profile	300	450	13	450	Alumínio anodizado Aluminum anodised	± 65

Juntas sísmicas de parede e teto montadas a superfície
Surface mounted seismic wall and ceiling expansion joint profiles

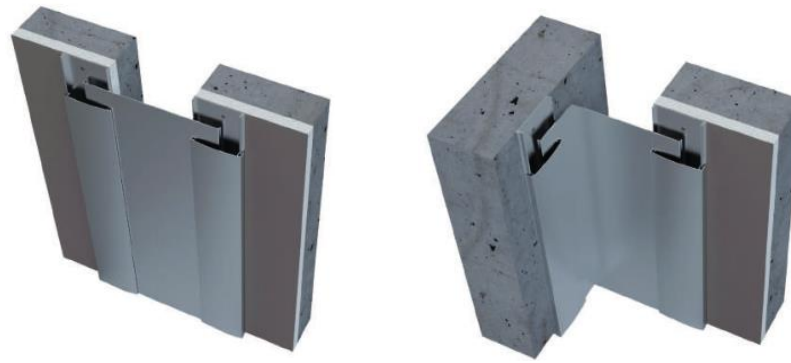

» COR 100_291

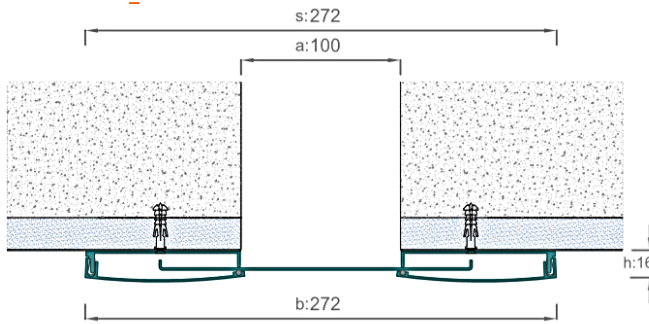

» COR 100K_291

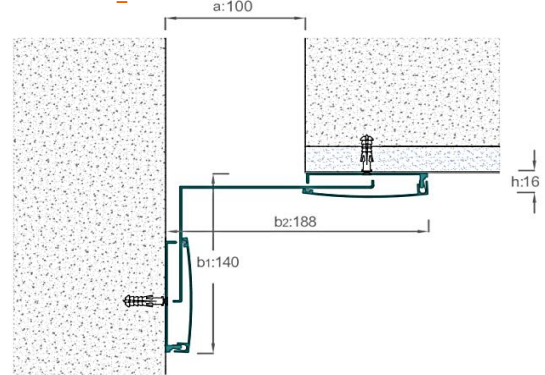

» COR 150_291

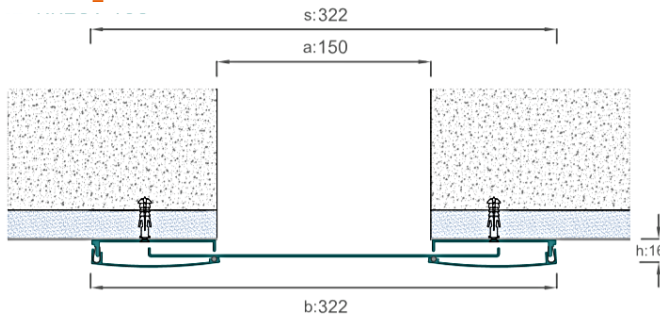

» COR 150K_291

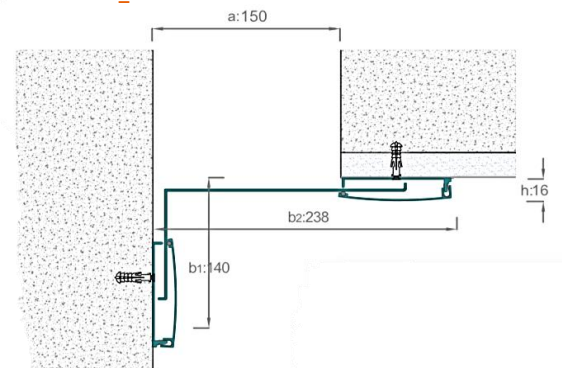

Juntas sísmicas de pavimentos, parede e teto
Seismic floor, wall, ceiling profiles

As juntas sísmicas de parede e teto têm a superfície lateral larga e decorativa. Pode ser entregue com revestimento em pó ou anodizado.

Seismic wall and ceiling profiles have the wide and decorative side surface. Can be delivered by powder coated or anodized.



REF	DESCRIÇÃO DESCRIPTION	LARGURA DA JUNTA (a) mm JOINT WIDTH	SUPERFÍCIE VISÍVEL (b) mm SURFACE VISIBLE	ALTURA PERFIL (h) mm PROFILE HEIGHT	LARGURA DA TOTAL (s) mm TOTAL WIDTH	SUPERFÍCIE SURFACE	CAPACIDADE MOVIMENTO MOVEMENT CAPACITY
COR_050_291	Superfície superior de alumínio, junta sísmica de parede e teto anodizado Aluminum top surface, anodized seismic wall and ceiling profile	50	222	16	222	Alumínio anodizado Aluminum anodised	± 50
COR_100_291	Superfície superior de alumínio, junta sísmica de parede e teto anodizado Aluminum top surface, anodized seismic wall and ceiling profile	100	272	16	272	Alumínio anodizado Aluminum anodised	± 75
COR_150_291	Superfície superior de alumínio, junta sísmica de parede e teto anodizado Aluminum top surface, anodized seismic wall and ceiling profile	150	322	16	322	Alumínio anodizado Aluminum anodised	± 75
COR_200_291	Superfície superior de alumínio, junta sísmica de parede e teto anodizado Aluminum top surface, anodized seismic wall and ceiling profile	200	372	16	372	Alumínio anodizado Aluminum anodised	± 75
COR_250_291	Superfície superior de alumínio, junta sísmica de parede e teto anodizado Aluminum top surface, anodized seismic wall and ceiling profile	250	422	16	422	Alumínio anodizado Aluminum anodised	± 75
COR_300_291	Superfície superior de alumínio, junta sísmica de parede e teto anodizado Aluminum top surface, anodized seismic wall and ceiling profile	300	472	16	472	Alumínio anodizado Aluminum anodised	± 75
COR_350_291	Superfície superior de alumínio, junta sísmica de parede e teto anodizado Aluminum top surface, anodized seismic wall and ceiling profile	350	522	16	522	Alumínio anodizado Aluminum anodised	± 75
COR_400_291	Superfície superior de alumínio, junta sísmica de parede e teto anodizado Aluminum top surface, anodized seismic wall and ceiling profile	400	572	16	572	Alumínio anodizado Aluminum anodised	± 75

Juntas sísmicas de parede e teto montadas a superfície
Surface mounted seismic wall and ceiling expansion joint profiles

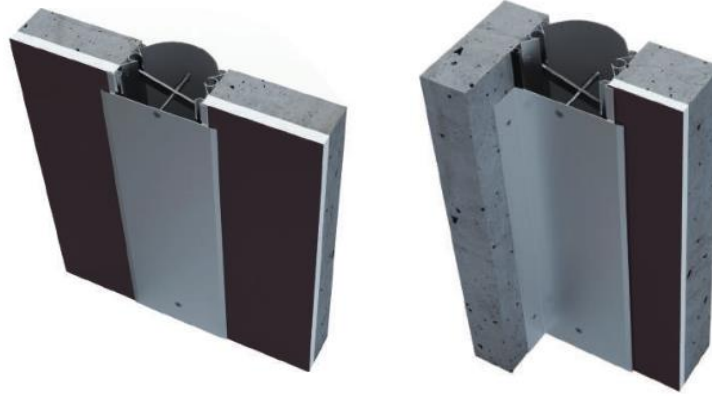

» COR 100_286

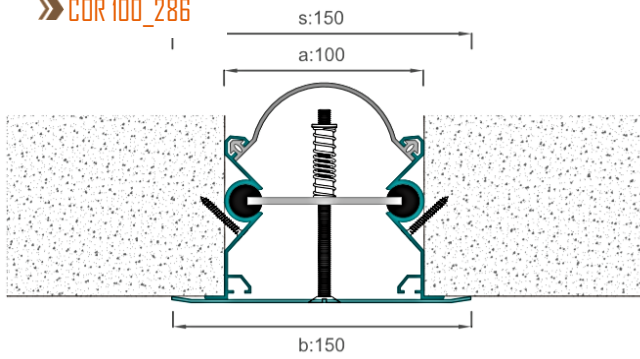

» COR 100K_286

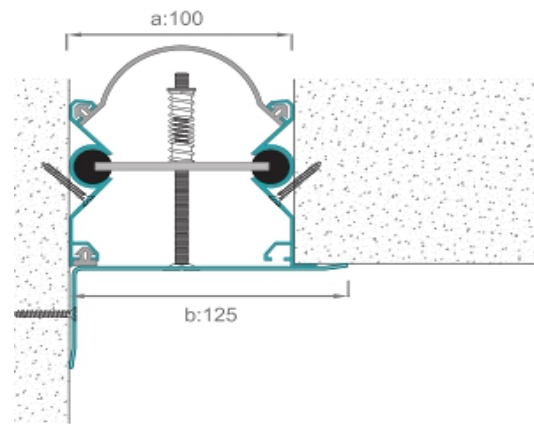

» COR 150_286

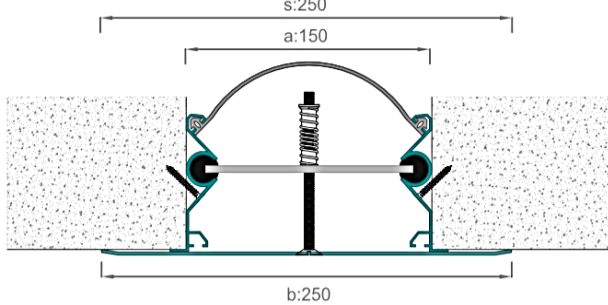

» COR 150K_286

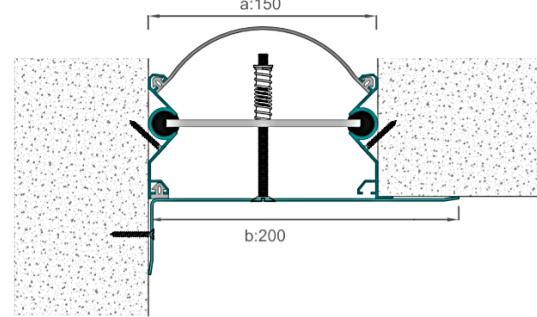

Juntas sísmicas de pavimentos, parede e teto
Seismic floor, wall, ceiling profiles

AS junta de dilatação de parede e teto COR 286 possuem barreiras de vapor e capacidade de movimento na direção tridimensional. (com parafuso montado no meio). Especialmente adequado para fachadas.

COR 286 wall and ceiling expansion joint profiles have vapor barriers and movement capacity in 3-dimensional direction. (with screw mounted in the middle). Especially suitable for facade.



REF	DESCRIÇÃO DESCRIPTION	LARGURA DA JUNTA (a) mm JOINT WIDTH	SUPERFÍCIE VISÍVEL (b) mm SURFACE VISIBLE	LARGURA DA TOTAL (s) mm TOTAL WIDTH	SUPERFÍCIE SURFACE	CAPACIDADE MOVIMENTO MOVEMENT CAPACITY
COR_100_286	Junta sísmica de parede e teto anodizado de superfície superior em alumínio Anodized, aluminum top surface seismic wall and ceiling profile	100	150	206	Alumínio anodizado Aluminum anodised	+40/-50
COR_150_286	Junta sísmica de parede e teto anodizado de superfície superior em alumínio Anodized, aluminum top surface seismic wall and ceiling profile	150	250	256	Alumínio anodizado Aluminum anodised	+60/-75
COR_200_286	Junta sísmica de parede e teto anodizado de superfície superior em alumínio Anodized, aluminum top surface seismic wall and ceiling profile	200	350	306	Alumínio anodizado Aluminum anodised	+60/-100
COR_250_286	Junta sísmica de parede e teto anodizado de superfície superior em alumínio Anodized, aluminum top surface seismic wall and ceiling profile	250	400	356	Alumínio anodizado Aluminum anodised	+60/-125
COR_300_286	Junta sísmica de parede e teto anodizado de superfície superior em alumínio Anodized, aluminum top surface seismic wall and ceiling profile	300	500	406	Alumínio anodizado Aluminum anodised	+60/-150

Juntas sísmicas de parede e teto montadas a superfície
Surface mounted seismic wall and ceiling expansion joint profiles



»» COR 150_293

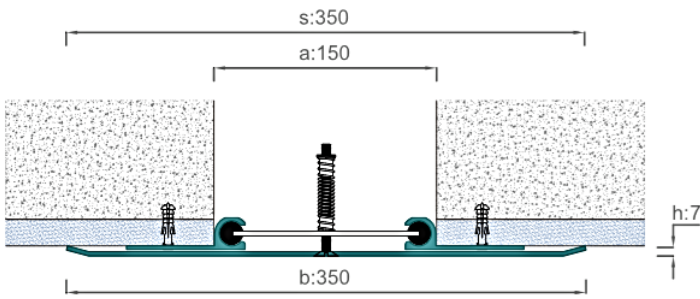

»» COR 150K_293

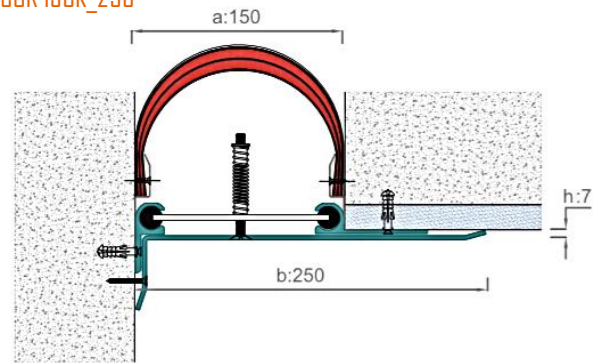

»» COR 200_293

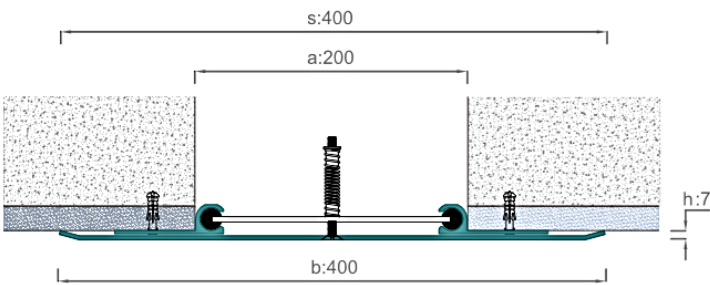

»» COR 200K_293

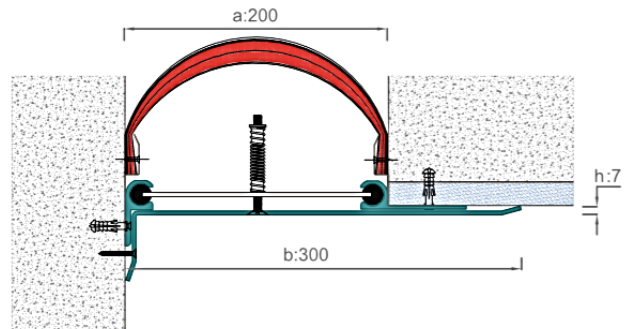

Juntas sísmicas de pavimentos, parede e teto
Seismic floor, wall, ceiling profiles

As juntas de dilatação de cobertura são adequados para paredes e tetos de estacionamentos e paredes onde é necessária grande capacidade de movimentação. Pode ser produzido por anodizado ou pó revestido na cor desejada.

Cover expansion joint profiles are suitable for car park walls and ceilings and walls where large movement capacity is being required. Can be produced by anodized or powder coated in required color.



REF	DESCRIÇÃO DESCRIPTION	LARGURA DA JUNTA (a) mm JOINT WIDTH	SUPERFÍCIE VISÍVEL (b) mm SURFACE VISIBLE	ALTURA PERFIL (h) mm PROFILE HEIGHT	LARGURA DA TOTAL (s) mm TOTAL WIDTH	SUPERFÍCIE SURFACE	CAPACIDADE MOVIMENTO MOVEMENT CAPACITY
COR_100_293	Junta sísmica de parede e teto anodizado de superfície superior em alumínio Anodized, aluminum top surface seismic wall and ceiling profile	100	300	7	300	Alumínio anodizado Aluminum anodised	± 50
COR_150_293	Junta sísmica de parede e teto anodizado de superfície superior em alumínio Anodized, aluminum top surface seismic wall and ceiling profile	150	350	7	350	Alumínio anodizado Aluminum anodised	± 75
COR_200_293	Junta sísmica de parede e teto anodizado de superfície superior em alumínio Anodized, aluminum top surface seismic wall and ceiling profile	200	400	7	400	Alumínio anodizado Aluminum anodised	± 100
COR_250_293	Junta sísmica de parede e teto anodizado de superfície superior em alumínio Anodized, aluminum top surface seismic wall and ceiling profile	250	500	7	500	Alumínio anodizado Aluminum anodised	± 125
COR_300_293	Junta sísmica de parede e teto anodizado de superfície superior em alumínio Anodized, aluminum top surface seismic wall and ceiling profile	300	600	7	600	Alumínio anodizado Aluminum anodised	± 150

Juntas para estacionamientos
Car park expansion joint profiles

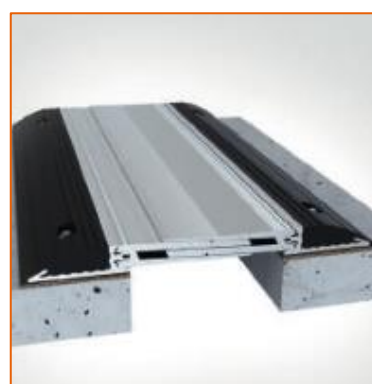

Junta de dilatação de pavimento para parques de estacionamento
Car park flush mounted floor expansion joint profiles



» COR 050_910

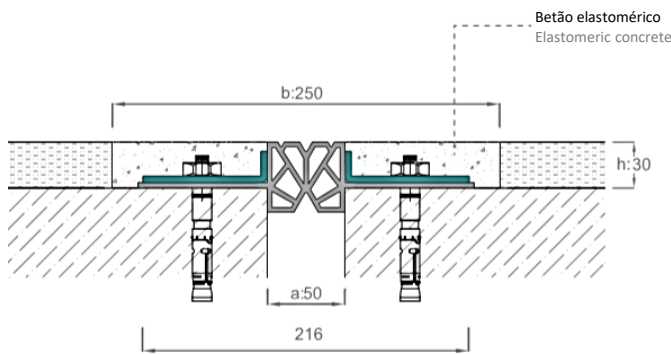

» COR 050K_910 (Detalhe de canto / Corner detail)

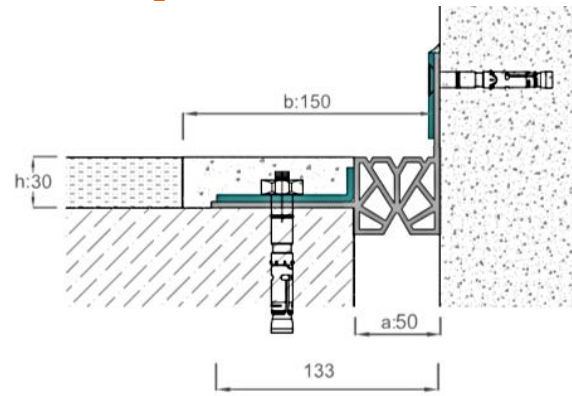

» COR 100_910

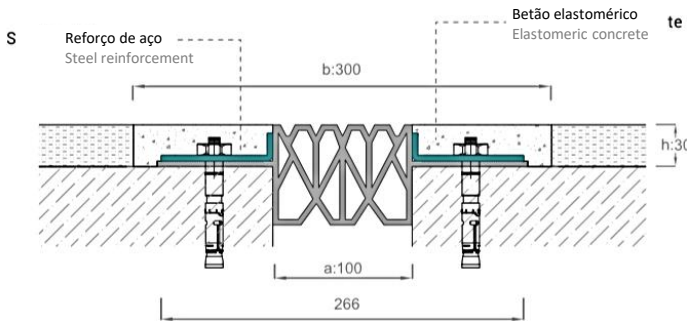

» COR 100K_910 (Detalhe de canto / Corner detail)

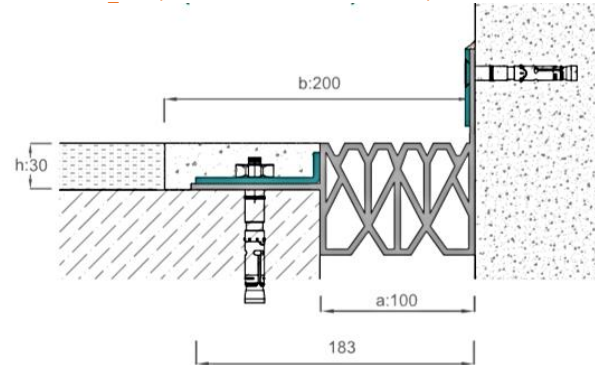

Perfis de junta de dilatação de estacionamento
Car park expansion joint profiles

As juntas de dilatação de parque de estacionamento com base em TPE e TPV podem chegar ao solo em apenas uma hora. Com características como alta capacidade de dobrar e encolher e resistente à corrosão, a Série COR 910 é adequada para aplicar betão de base altamente polimérica.

TPE and TPV based car park expansion joint profiles are able to the ground only in an hour time. Having such characteristics as high capacity to bend Shrink and resistant to corrosion make COR 910 Series Suitable to apply highly polymeric based concrete.



REF	DESCRIÇÃO DESCRIPTION	LARGURA DA JUNTA (a) mm JOINT WIDTH	SUPERFÍCIE VISÍVEL (b) mm SURFACE VISIBLE	ALTURA (h) mm PROFILE HEIGHT	LARGURA (s) mm TOTAL WIDTH	SUPERFÍCIE SURFACE	CAPACIDADE MOVIMENTO MOVEMENT CAPACITY	CAPACIDADE CARGA LOAD CAPACITY
COR_050_910	Montado com juntas de aço Assembled with steel profiles	50	250	30	250	TPE + Aço TPE + Steel	± 25	30 Ton
COR_100_910	Montado com juntas de aço Assembled with steel profiles	100	300	30	300	TPE + Aço TPE + Steel	± 50	30 Ton

Junta de dilatação de pavimento para parques de estacionamento
 Car park flush mounted floor expansion joint profiles

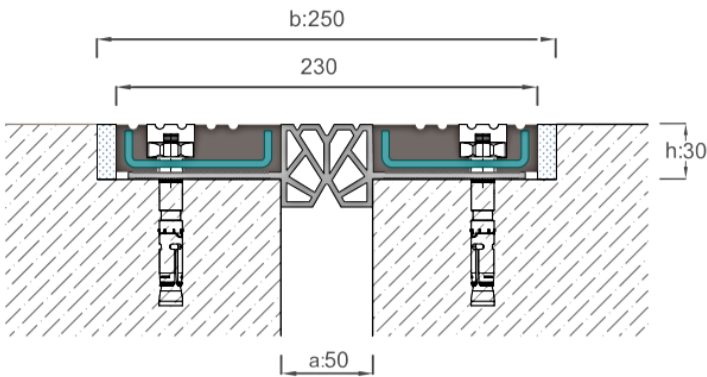

» COR 050_911

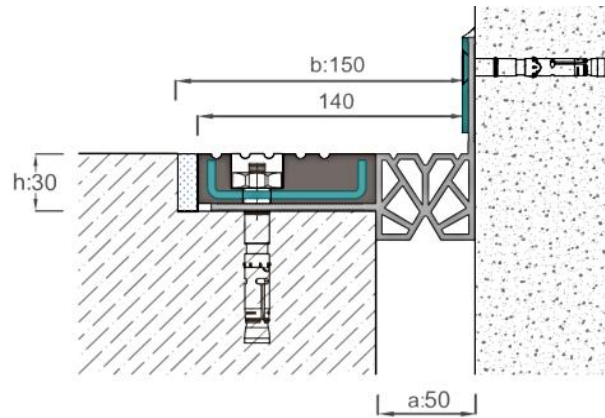

» COR 050K_910 (Detalhe de canto / Corner detail)

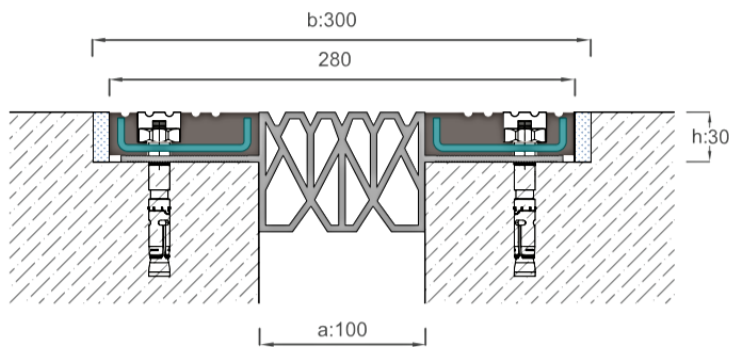

» COR 100_911



» COR 100K_911 (Detalhe de canto / Corner detail)

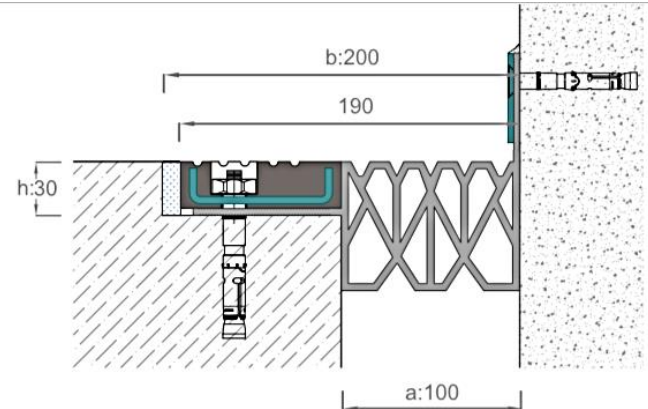

 Perfis de junta de dilatação
 de estacionamento
 Car park expansion joint
 profiles

As partes intermediárias TPV e TPE são resistentes a cargas pesadas, confortáveis, silenciosas e impermeáveis quando montadas corretamente. Além disso, as juntas laterais vulcanizadas são reforçadas com chapas de aço.

TPV AND TPE middle parts are resistant to heavy loads, comfortable, quite and waterproofing when mounted properly. Furthermore, vulcanized side profiles are reinforced with steel plates.

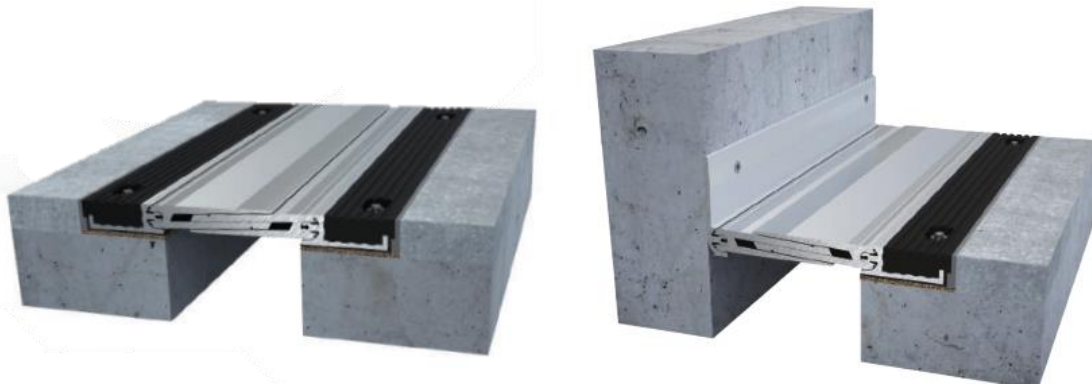

REF	DESCRIÇÃO DESCRIPTION	LARGURA DA JUNTA (a) mm JOINT WIDTH	SUPERFÍCIE VISÍVEL (b) mm SURFACE VISIBLE	ALTURA (h) mm PROFILE HEIGHT	LARGURA (s) mm TOTAL WIDTH	SUPERFÍCIE SURFACE	CAPACIDADE MOVIMENTO MOVEMENT CAPACITY	CAPACIDADE CARGA LOAD CAPACITY
COR_050_911	Juntas de pavimento compósito reforçado em aço Steel reinforced composite floor profile	50	250	30	250	Borracha + TPE Rubber + TPE	± 25	30 Ton
COR_051_911	Perfil de piso compósito reforçado em aço Steel reinforced composite floor profile	50	250	30	250	Borracha + TPE Rubber + TPE	± 40	30 Ton
COR_100_911	Perfil de piso compósito reforçado em aço Steel reinforced composite floor profile	100	300	30	300	Borracha + TPE Rubber + TPE	± 50	30 Ton

Junta de dilatação de pavimento para parques de estacionamento
 Car park flush mounted floor expansion joint profiles

» COR 150_911

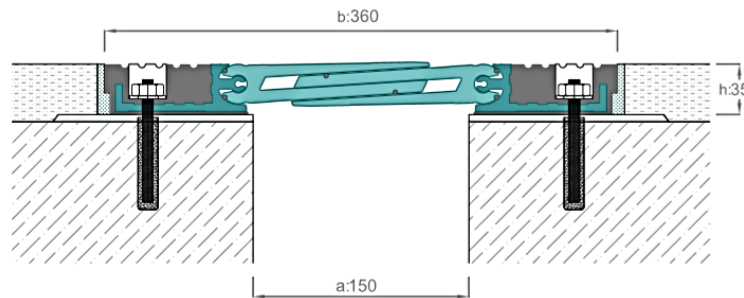

» COR 200_911

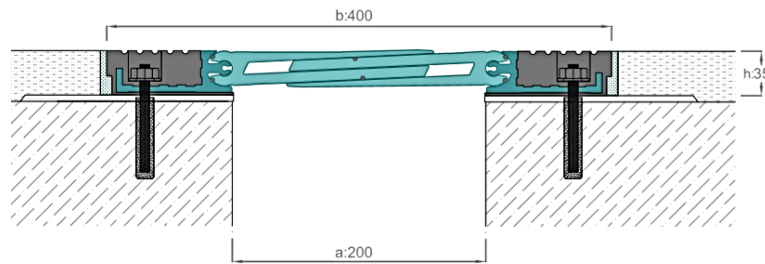

» COR 150K_911

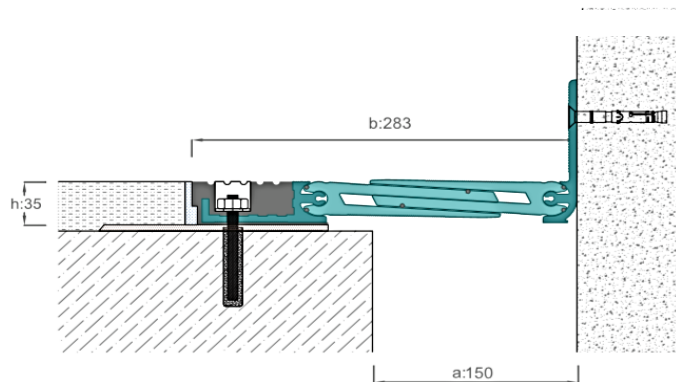
 Perfis de junta de dilatação
 de estacionamento
 Car park expansion joint
 profiles

Criados pela primeira vez no mundo, estas juntas de dilatação de borracha + alumínio foram aplicadas com sucesso em amplas folgas de juntas de dilatação em parques de estacionamento e estruturas industriais.

Created for the first time in the world, these rubber + aluminum dilatation profiles successfully applied to wide expansion joint gaps in carparks and industrial structures. Provide opportunity to be quite and comfortable.

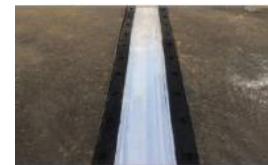

REF	DESCRIÇÃO DESCRIPTION	LARGURA DA JUNTA (a) mm JOINT WIDTH	SUPERFÍCIE VISÍVEL (b) mm SURFACE VISIBLE	ALTURA (h) mm PROFILE HEIGHT	LARGURA (s) mm TOTAL WIDTH	SUPERFÍCIE SURFACE	CAPACIDADE MOVIMENTO MOVEMENT CAPACITY	CAPACIDADE CARGA LOAD CAPACITY
COR_150_911	Juntas de pavimento compósito, borracha e alumínio Composite, rubber, aluminum floor profile	150	360	35	360	Acabamento ALU + Borracha Mill finish ALU + Rubber	+35/-25	30 Ton
COR_200_911	Juntas de pavimento compósito, borracha e alumínio Composite, rubber, aluminum floor profile	200	400	35	400	Acabamento ALU + Borracha Mill finish ALU + Rubber	± 40	16 Ton
COR_250_911	Juntas de pavimento compósito, borracha e alumínio Composite, rubber, aluminum floor profile	250	450	35	450	Acabamento ALU + Borracha Mill finish ALU + Rubber	± 40	9 Ton
COR_300_911	Juntas de pavimento compósito, borracha e alumínio Composite, rubber, aluminum floor profile	300	500	35	500	Acabamento ALU + Borracha Mill finish ALU + Rubber	± 40	6,5 Ton

Juntas de dilatação de pavimento de superfície para parques de estacionamento Car park surface mounted floor expansion joint profiles



» COR 050_921

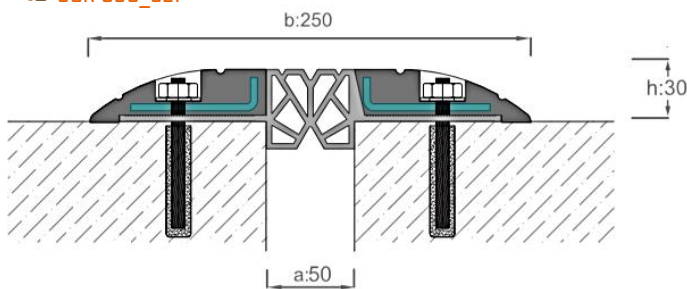

» COR 051_921

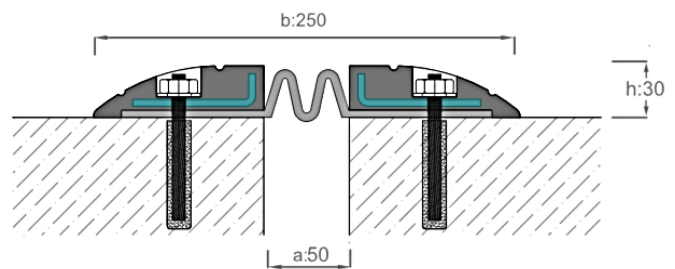

» COR 100_921

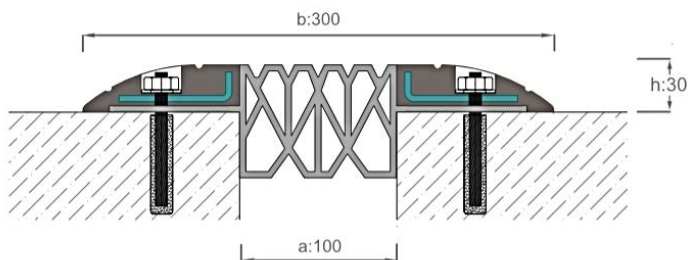

» COR 100K_921

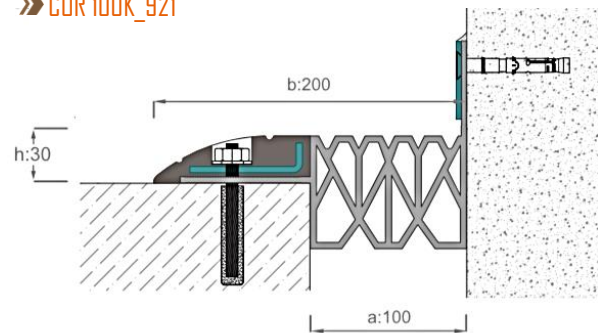
 Perfis de junta de dilatação
de estacionamento
Car park expansion joint
profiles

A série COR 921 são juntas de dilatação de borracha e aço. Aplicado em pavimentos sobre juntas de acabamento e pode ser usada como um amortecedor de velocidade. É montada no chão por âncoras de aço adequadas a ter juntas de 25 cm no meio.

COR 921 series are rubber + steel composite expansion joint profiles. Applied to floors over finish profiles and can be used as a speed bumper. Ass wall assembled to the floor by appropriate steel anchors of having 25cm gaps in between.



REF	DESCRIÇÃO DESCRIPTION	LARGURA DA JUNTA (a) mm JOINT WIDTH	SUPERFÍCIE VISÍVEL (b) mm SURFACE VISIBLE	ALTURA (h) mm PROFILE HEIGHT	LARGURA (s) mm TOTAL WIDTH	SUPERFÍCIE SURFACE	CAPACIDADE MOVIMENTO MOVEMENT CAPACITY	CAPACIDADE CARGA LOAD CAPACITY
COR_050_921	Para-choques de velocidade, composto, borracha, junta de aço Speed bumper, Composite, rubber, steel profile	50	250	30	250	Borracha + TPE Rubber + TPE	± 25	9 Ton
COR_051_921	Para-choques de velocidade, composto, borracha, junta de aço Speed bumper, Composite, rubber, steel profile	50	250	30	250	Borracha + TPE Rubber + TPE	± 40	9 Ton
COR_100_921	Para-choques de velocidade, composto, borracha, junta de aço Speed bumper, Composite, rubber, steel profile	100	300	30	300	Borracha + TPE Rubber + TPE	± 50	9 Ton
COR_101_921	Para-choques de velocidade, composto, borracha, junta de aço Speed bumper, Composite, rubber, steel profile	100	300	30	300	Acabamento ALU + Borracha Mill finish ALU + Rubber	± 20	9 Ton
COR_150_921	Para-choques de velocidade, composto, borracha, junta de aço Speed bumper, Composite, rubber, steel profile	150	350	30	350	Acabamento ALU + Borracha Mill finish ALU + Rubber	± 20	9 Ton
COR_200_921	Para-choques de velocidade, composto, borracha, junta de aço Speed bumper, Composite, rubber, steel profile	200	462	35	462	Acabamento ALU + Borracha Mill finish ALU + Rubber	± 40	9 Ton
COR_250_921	Para-choques de velocidade, composto, borracha, junta de aço Speed bumper, Composite, rubber, steel profile	250	512	35	512	Acabamento ALU + Borracha Mill finish ALU + Rubber	± 50	9 Ton
COR_300_921	Para-choques de velocidade, composto, borracha, junta de aço Speed bumper, Composite, rubber, steel profile	300	562	35	562	Acabamento ALU + Borracha Mill finish ALU + Rubber	± 60	9 Ton

Junta de dilatação de pavimento para parques de estacionamento
Car park flush mounted floor expansion joint profiles



» COR 101_921

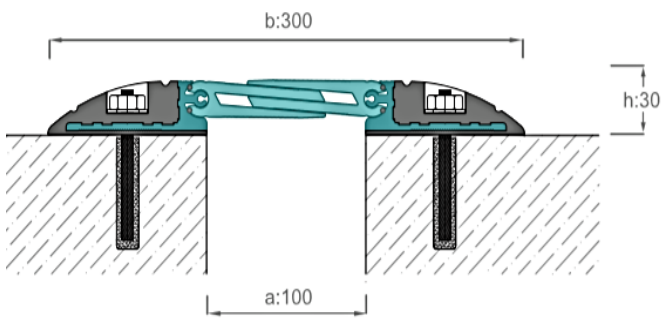

» COR 150_921

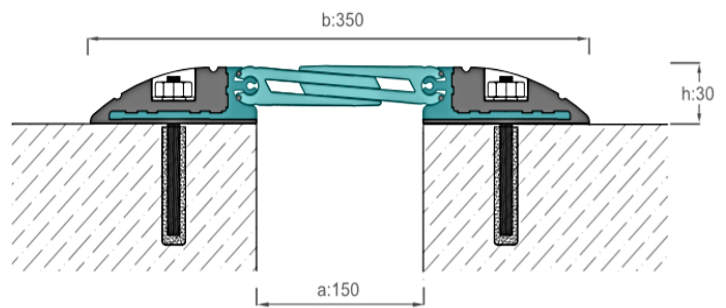

Perfis de junta de dilatação de estacionamento
Car park expansion joint profiles

» COR 200_921

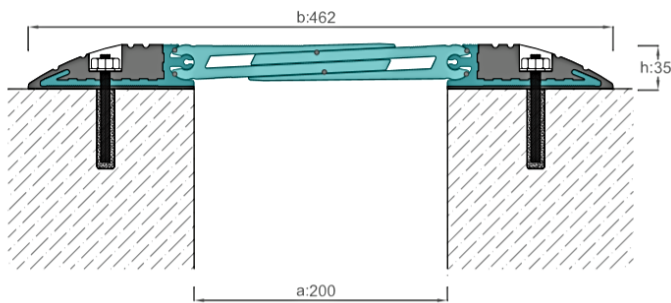

» Detalhe de canto / Corner detail

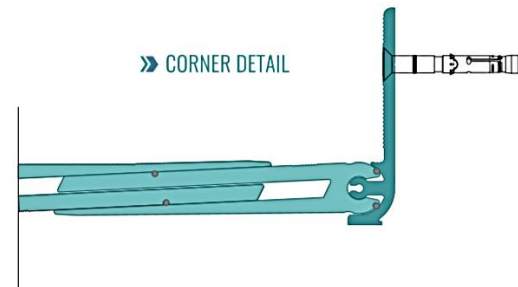

Desenvolvidos pela primeira vez no mundo, as juntas de dilatação de alumínio + borracha TPE também apresentam os detalhes dos cantos de cada projeto.
Developed of the first time in the world, aluminum + TPE rubber expansion joint profiles also have the corner detail in each design.

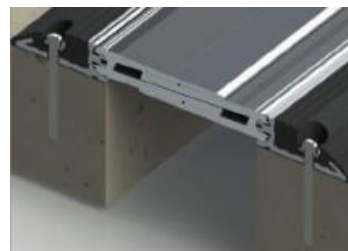

Junta de dilatação de pavimento para parques de estacionamento
 Car park flush mounted floor expansion joint profiles

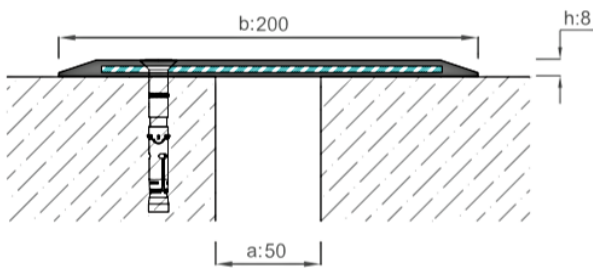

» COR 050_951

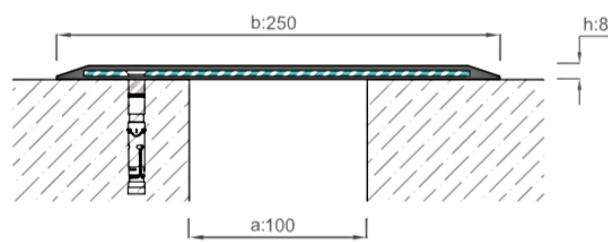

» COR 100_951

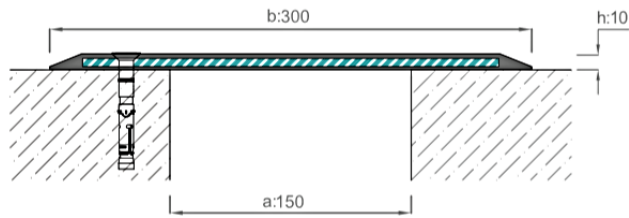

» COR 150_951

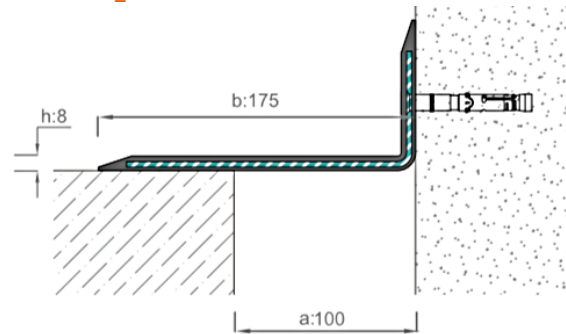

» COR 100K_951

 Perfis de junta de dilatação
 de estacionamento
 Car park expansion joint
 profiles

A série COR 951 é uma junta de dilatação composta por borracha + aço. Aplicada no chão e pode ser usada como pára-choques de velocidade. Montada no chão por âncoras de aço apropriadas, com intervalos de 25 cm.

COR 951 series are rubber + steel composite expansion joint profiles. Applied to floors and can be used as a speed bumper. Assembled to the floor by appropriate steel anchors of having 25cm intervals.



REF	DESCRIÇÃO DESCRIPTION	LARGURA DA JUNTA (a) mm JOINT WIDTH	SUPERFÍCIE VISÍVEL (b) mm SURFACE VISIBLE	ALTURA (h) mm PROFILE HEIGHT	ST37 ESPESSURA DO AÇO (mm) STEEL THICKNESS	LARGURA (s) mm TOTAL WIDTH	SUPERFÍCIE SURFACE	CAPACIDADE MOVIMENTO MOVEMENT CAPACITY	CAPACIDADE CARGA LOAD CAPACITY
COR_050_951	Compósito, borracha, juntas de pavimento de aço Composite, rubber, steel floor profile	50	200	8	3	200	Borracha Rubber	+50	9 Ton
COR_100_951	Compósito, borracha, juntas de pavimento de aço Composite, rubber, steel floor profile	80-100	250	8	3	250	Borracha Rubber	+50/-100	9 Ton
COR_150_951	Compósito, borracha, juntas de pavimento de aço Composite, rubber, steel floor profile	120-150	300	10	4	300	Borracha Rubber	+50/-150	6 Ton
COR_180_951	Compósito, borracha, juntas de pavimento de aço Composite, rubber, steel floor profile	180-200	350	12	5	350	Borracha Rubber	+65/-180	3,5 Ton
COR_250_951	Compósito, borracha, Juntas de pavimento de aço Composite, rubber, steel floor profile	250	400	12	6	400	Borracha Rubber	+65/-250	3,5 Ton
COR_300_951	Compósito, borracha, junta de pavimento de aço Composite, rubber, steel floor profile	300	600	15	8	600	Borracha Rubber	+28	3,5 Ton

Junta de dilatação de pavimento para parques de estacionamento Car park flush mounted floor expansion joint profiles



» COR 300_951

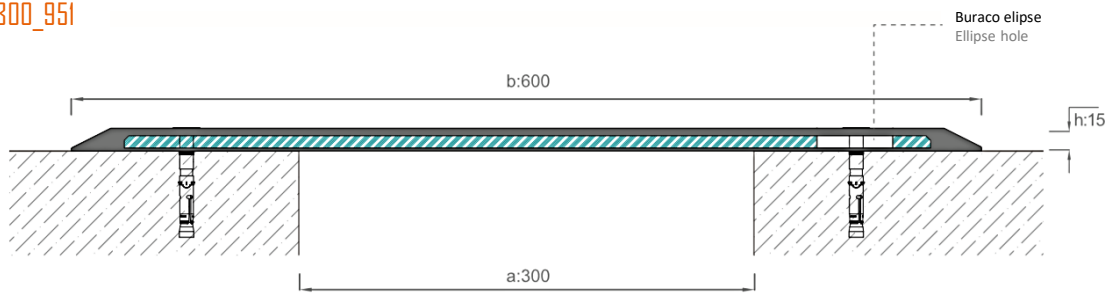

Perfis de junta de dilatação de estacionamento
Car park expansion joint profiles

» COR 050_192

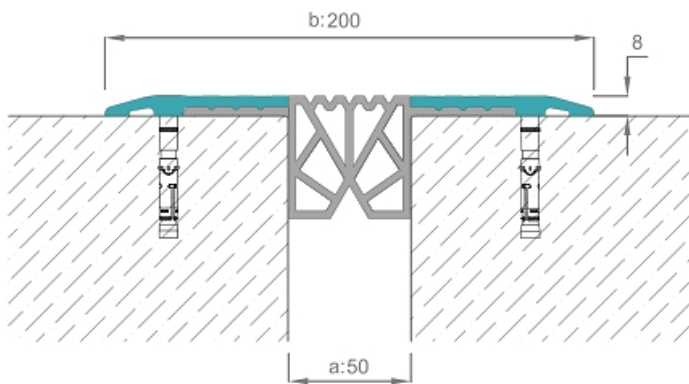

» COR 050_194

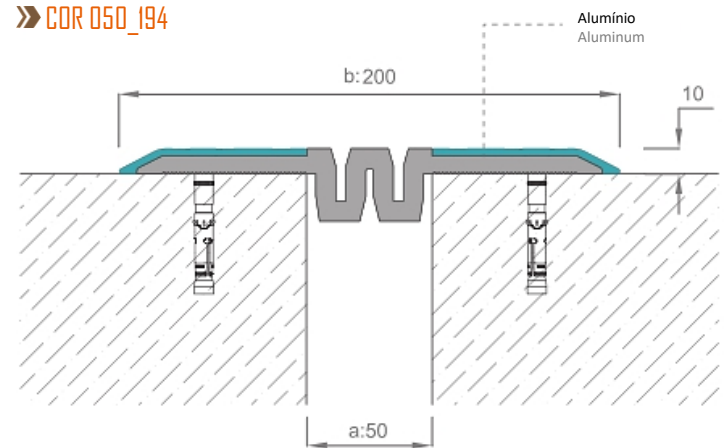

As juntas de dilatação à superfície de alumínio ou aço inoxidável são adequados para juntas de estacionamento de pavimento montadas na superfície.

Aluminum or stainless steel top surfaced expansion joint profiles are suitable for surface mounted floor carpark profiles.



REF	DESCRIÇÃO DESCRIPTION	LARGURA DA JUNTA (a) mm JOINT WIDTH	SUPERFÍCIE VISÍVEL (b) mm SURFACE VISIBLE	ALTURA (h) mm PROFILE HEIGHT	LARGURA (s) mm TOTAL WIDTH	SUPERFÍCIE SURFACE	CAPACIDADE MOVIMENTO MOVEMENT CAPACITY	CAPACIDADE CARGA LOAD CAPACITY
COR_050_192	Junta de pavimento embutido com acabamento fresado Mill finish mounted floor profile	50	200	45	200	Acabamento ALU + TPE Mill finish ALU + TPE	± 25	9 Ton
COR_050_194	Junta de pavimento embutido com acabamento fresado Mill finish mounted floor profile	50	200	20	200	Acabamento ALU + TPE Mill finish ALU + TPE	± 25	9 Ton

Juntas de dilatação estanques e para
terraço
Watertight and terrace expansion joint
profiles

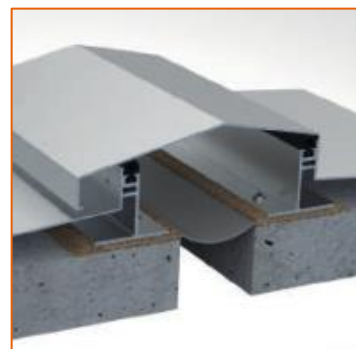

Juntas de dilatação totalmente estanques de embutir

Flush mounted floor completely watertight expansion joint profiles

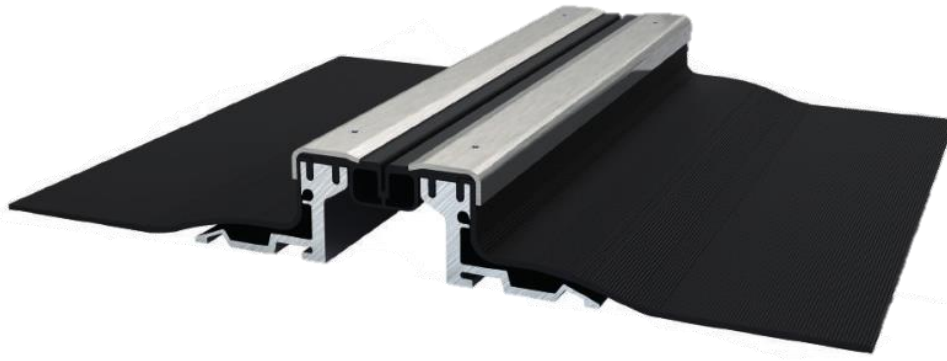

» COR_050_601

Aço inoxidável com 2,5 mm de espessura
2,5mm thickness stainless steel

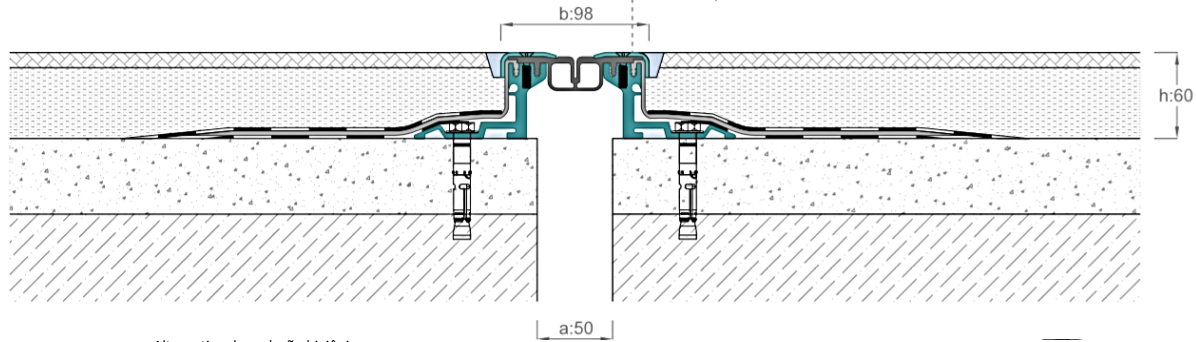

Alternativa de vedação higiênica
Hygienic gasket alternative



» COR_050A_600



» COR_050_600



» COR_050A_601



» COR_050A_602

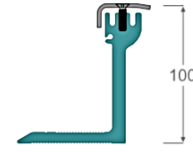

» COR_050A_603

» COR_050_601 SS

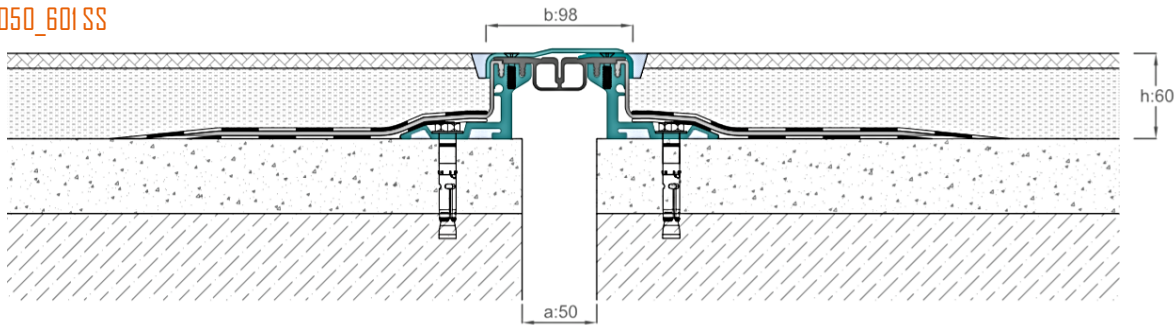

Juntas de dilatação
estanques
Complete watertight
expansion joint profiles

Aço inoxidável SS 304 sendo usado. adotável com membrana de betume de mistura de borracha.
SS 304 stainless steel being used. adoptable with rubber mixture bitumen membrane.

REF	DESCRIÇÃO DESCRIPTION	LARGURA DA JUNTA (a) mm JOINT WIDTH	SUPERFÍCIE VISÍVEL (b) mm SURFACE VISIBLE	ALTURA (h) mm PROFILE HEIGHT	LARGURA (s) mm TOTAL WIDTH	SUPERFÍCIE SURFACE	CAPACIDADE MOVIMENTO MOVEMENT CAPACITY	CAPACIDADE CARGA LOAD CAPACITY
COR_050A_600	Ideal para aplicações cerâmicas Ideal for ceramic applications	50	97	25	580	TPV + Aço inoxidável TPV + Stainless steel	+20	3,5 Ton
COR_050_600	Adequado para granito, mármore, Betão etc Suitable for granite, marble, concrete etc	50	98	50	560	TPV + Aço inoxidável TPV + Stainless steel	+20	15 Ton 6 Ton
COR_050_600 SS	Adequado para granito, mármore com superfície superior em aço inoxidável Suitable for granite, marble with stainless steel top surface	50	98	50	560	Aço inoxidável Stainless steel	+20	15 Ton 6 Ton
COR_050_601	Adequado para granito, mármore, Betão etc Suitable for granite, marble, concrete etc	50	98	60	540	TPV + Aço inoxidável TPV + Stainless steel	+20	15 Ton 6 Ton
COR_050_602	Adequado para granito, mármore, Betão etc Suitable for granite, marble, concrete etc	50	98	70	520	TPV + Aço inoxidável TPV + Stainless steel	+20	15 Ton 6 Ton
COR_050_603	Adequado para granito, mármore, Betão etc Suitable for granite, marble, concrete etc	50	98	100	460	TPV + Aço inoxidável TPV + Stainless steel	+20	15 Ton 6 Ton

Juntas de dilatação totalmente estanques de embutir
Flush mounted floor completely watertight expansion joint profiles



Juntas de dilatação
estanques
Complete watertight
expansion joint profiles

» COR 050_60I - K1

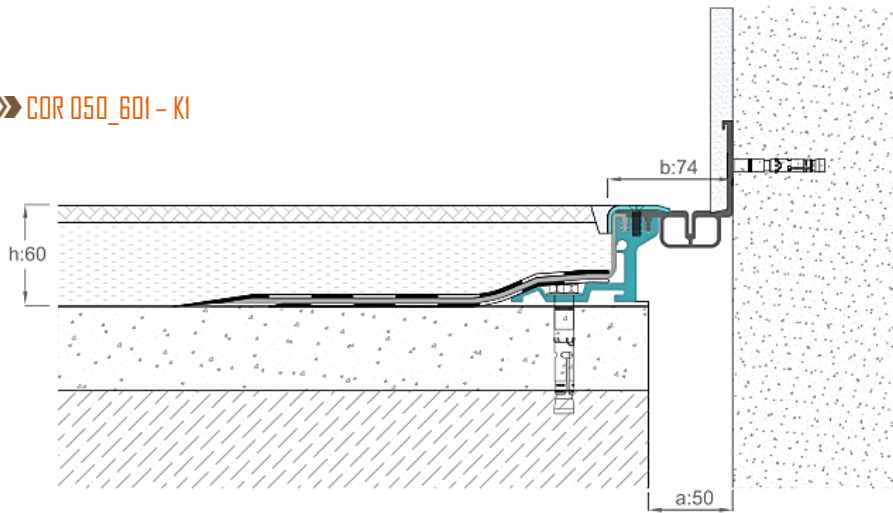

» COR 050_60I - K2

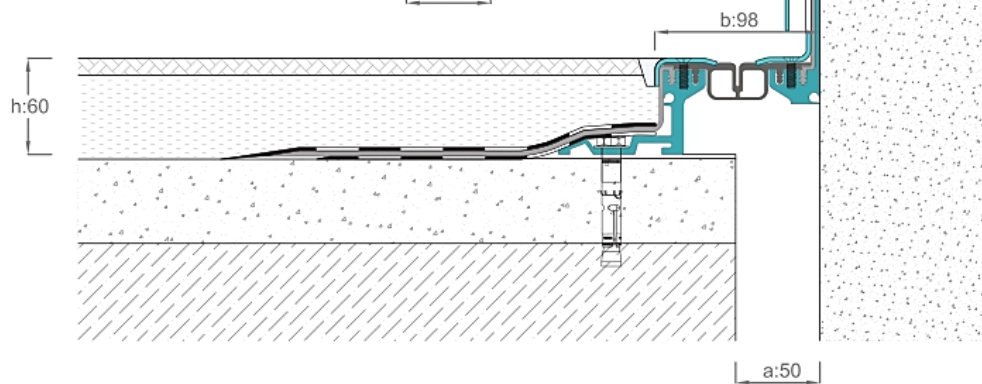

As junta de dilatação de asa lateral termoplástica do pavimento ao pavimento são compostos de alumínio e aço inoxidável (SS304). As juntas de dilatação à prova d'água são totalmente higiênicos e completam o pavimento, são conectadas a materiais de isolamento por aletas laterais e usadas em áreas molhadas e terraços. Juntas produzidos em comprimentos de 3 metros e juntas em 15 metros por rolos.

Floor to floor thermoplastic side winged expansion joint profiles are composite of aluminum and stainless steel (SS304). Materials hygienic and complete watertight floor expansion joint profiles are connected to isolation materials by side wings and used in wet areas and terraces. Profiles produced in 3 meters lengths and gaskets in 15 meters by rolls.



Juntas de dilatação totalmente estanques de embutir
Flush mounted floor completely watertight expansion joint profiles



» COR 050_600 - A

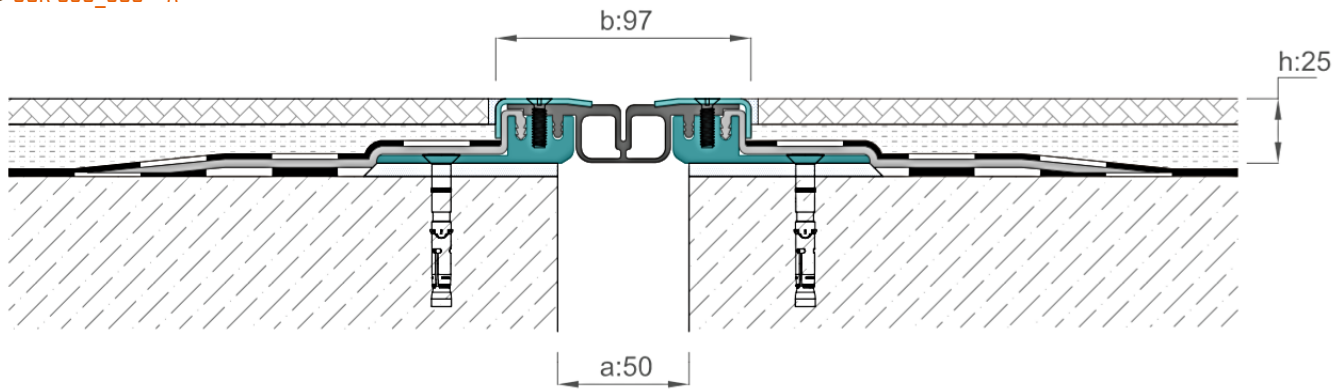

» COR 050_600 - A2

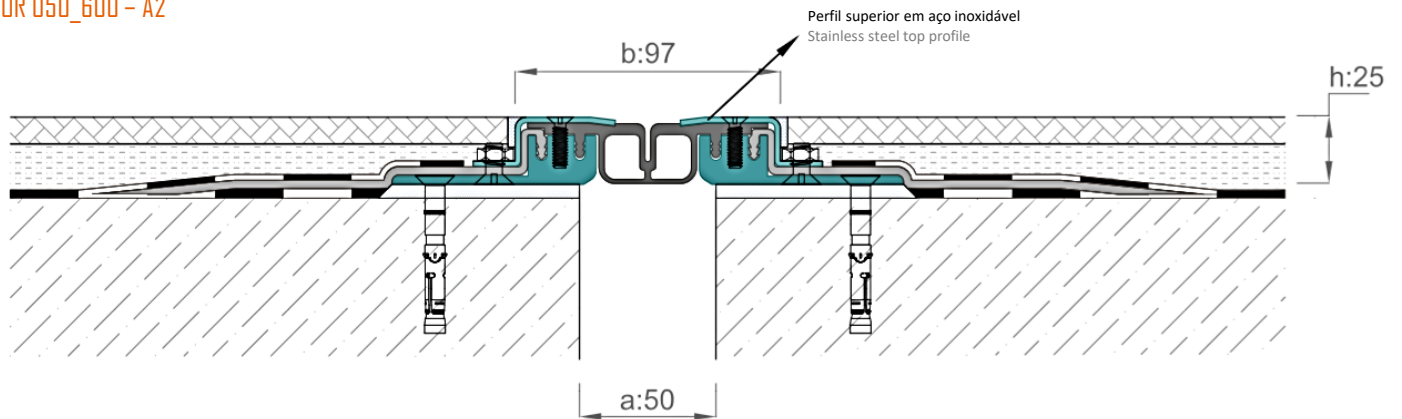

Juntas de dilatação
estanques
Complete watertight
expansion joint profiles

Estas juntas de dilatação são de montagem embutida e inseridas em TPE são utilizadas para áreas molhadas e terraços com baixa altura de cobertura.
These flush mounted and TPE inserted expansion joint profiles used for wet areas and terraces with low covering height.



Juntas de dilatação totalmente estanques de embutir
Flush mounted floor completely watertight expansion joint profiles



Juntas de dilatação
estanques
Complete watertight
expansion joint profiles

» COR 050_600 – AK1

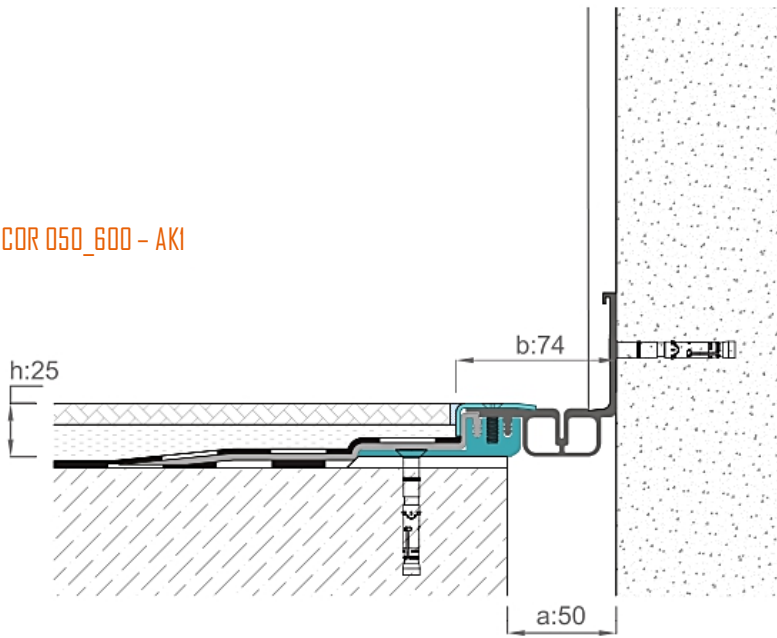

» COR 050_600 – AK2

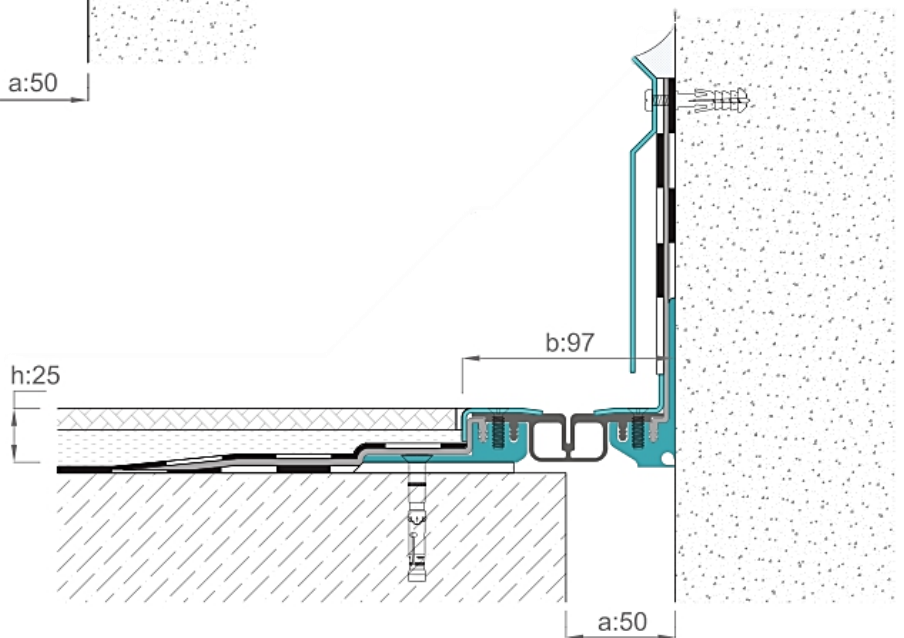

Juntas de dilatação totalmente estanques de embutir
 Flush mounted floor completely watertight expansion joint profiles

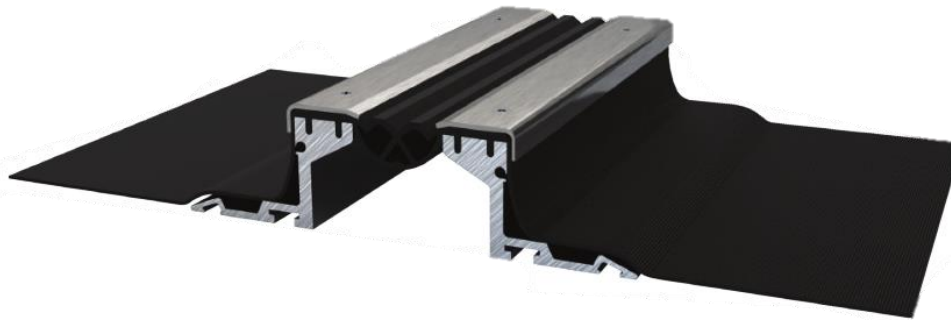

» COR 100_600

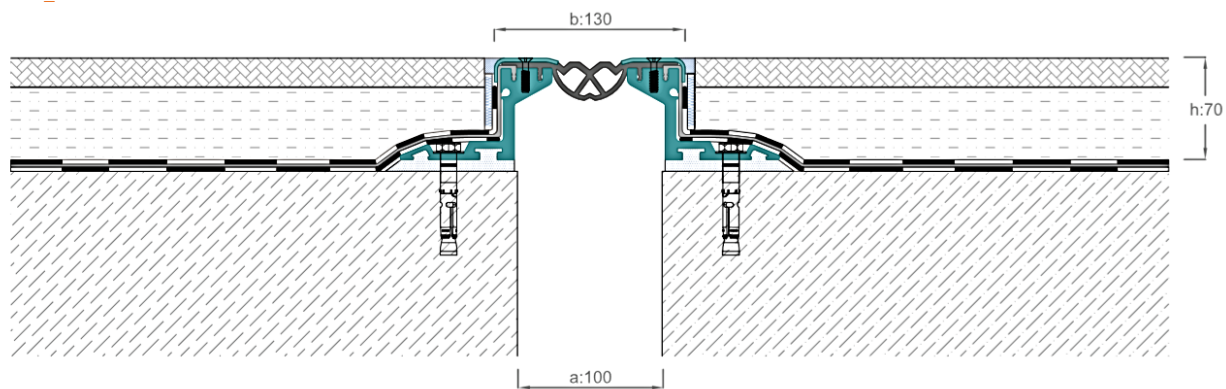

» COR 100_600 SS

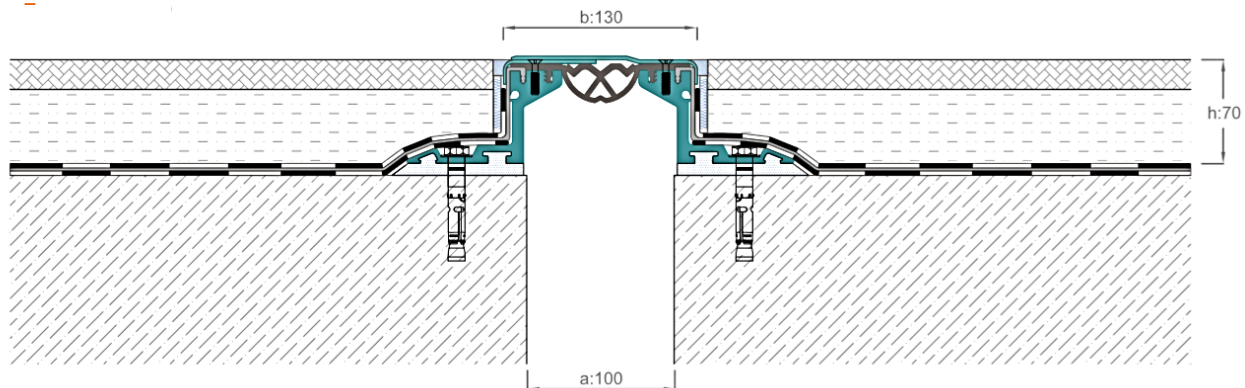

Juntas de dilatação
 estanques
 Complete watertight
 expansion joint profiles

Utilizam-se juntas de dilatação montadas na superfície, econômicos, em aço inoxidável, embutidos na superfície, para folgas nas juntas de 100 mm. Adicionalmente é adequado com membrana de betume de mistura de borracha.

Economic Stainless-steel top surface flush mounted expansion joint profiles are used for 100mm joint gaps. Additionally. Suitable with rubber mixture bitumen membrane.

REF	DESCRIÇÃO DESCRIPTION	LARGURA DA JUNTA (a) mm JOINT WIDTH	SUPERFÍCIE VISÍVEL (b) mm SURFACE VISIBLE	ALTURA (h) mm PROFILE HEIGHT	LARGURA (s) mm TOTAL WIDTH	SUPERFÍCIE SURFACE	CAPACIDADE MOVIMENTO MOVEMENT CAPACITY	CAPACIDADE CARGA LOAD CAPACITY
COR_100 600	Adequado para granito, mármore, Betão etc Suitable for granite, marble, concrete etc	100	130	70	580	TPV + Aço inoxidável TPV + Stainless steel	± 20	9 Ton 3,5 Ton
COR_100 600 SS	Adequado para granito, mármore com superfície superior em aço inoxidável Suitable for granite, marble with stainless steel top surface	100	130	70	580	Aço inoxidável Stainless steel	± 20	9 Ton 3,5 Ton

Juntas de dilatação totalmente estanques de embutir
 Flush mounted floor completely watertight expansion joint profiles



» COR 100_600

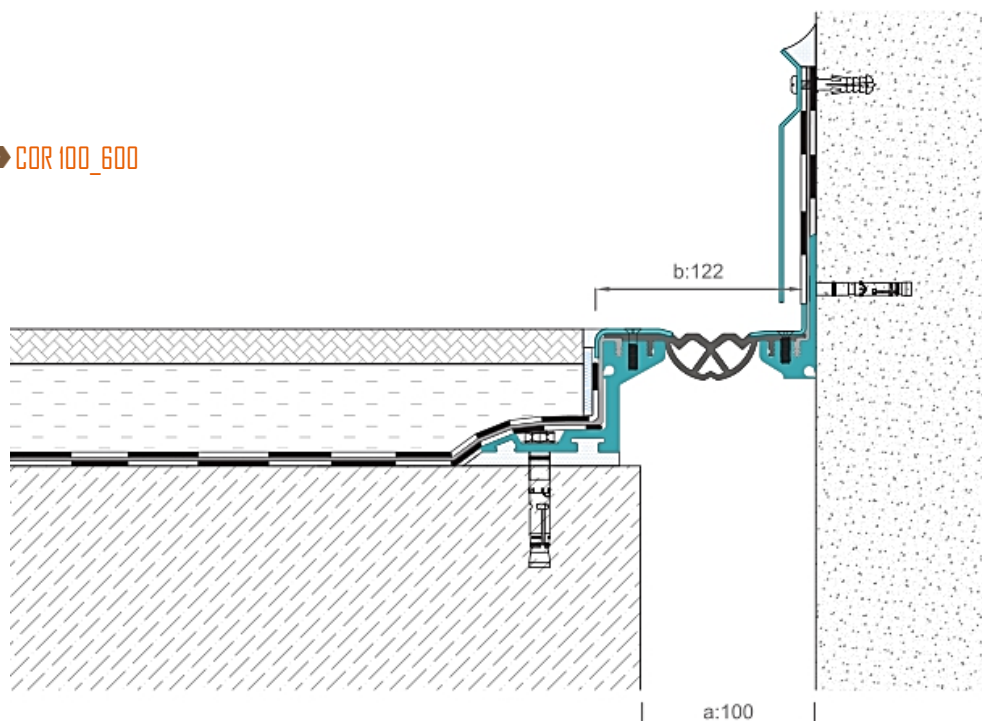

» COR 100_600 SSK

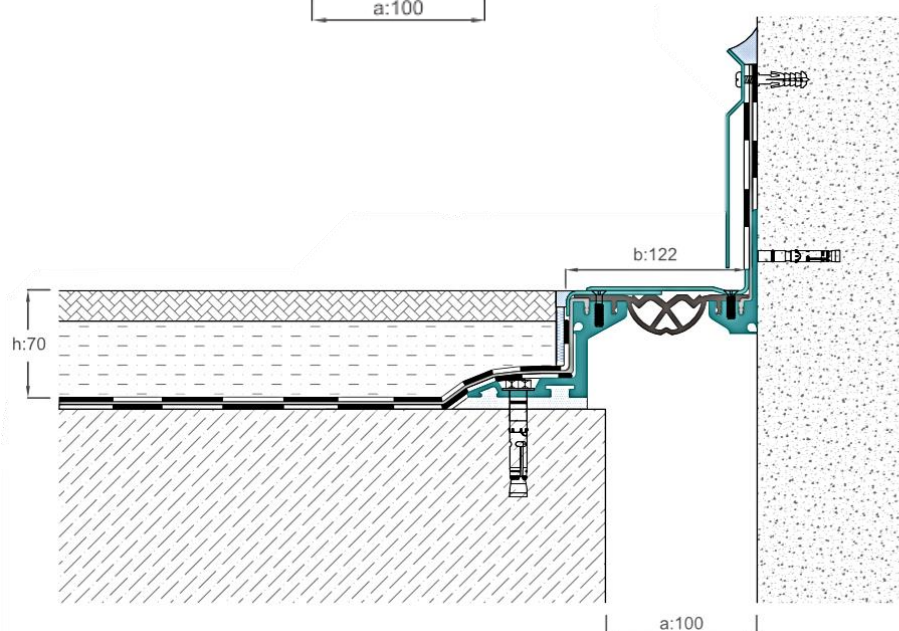

Juntas de dilatação
 estanques
 Complete watertight
 expansion joint profiles

Juntas de dilatação totalmente estanques de embutir
 Flush mounted floor completely watertight expansion joint profiles

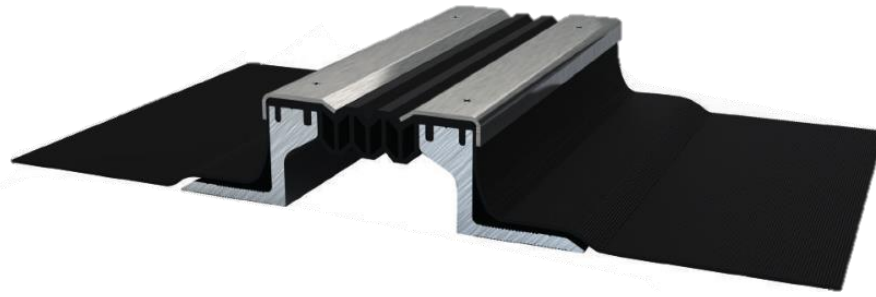

» COR 100_600

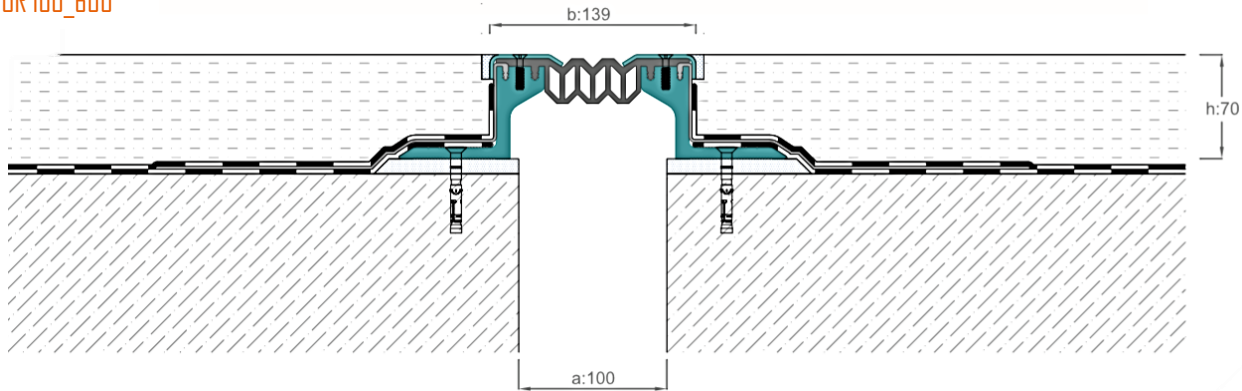

Juntas de dilatação
 estanques
 Complete watertight
 expansion joint profiles

» COR 101_600 SS

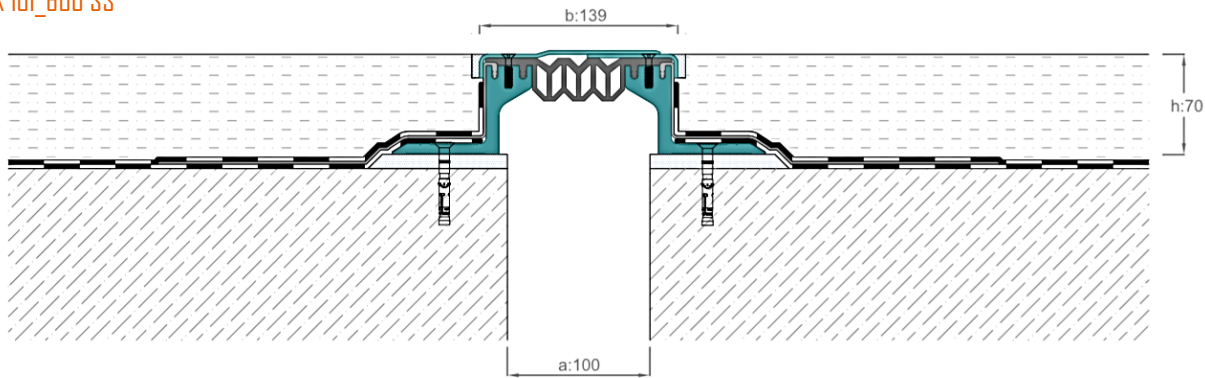

As juntas de dilatação inseridas em TPE e completamente estanques têm uma alta capacidade de movimentação. Danos mecânicos (parafusos, etc.) são evitados pela superfície superior higiênica e inserção TPE. A opção alternativa da junta completa em aço inoxidável também está disponível.

TPE inserted and completely watertight expansion joint profiles have the high capacity to move. Mechanical damages (screws etc.) are prevented by hygienic top surface and TPE insert. The alternative complete stainless-steel option is also available.



REF	DESCRIÇÃO DESCRIPTION	LARGURA DA JUNTA (a) mm JOINT WIDTH	SUPERFÍCIE VISÍVEL (b) mm SURFACE VISIBLE	ALTURA (h) mm PROFILE HEIGHT	LARGURA (s) mm TOTAL WIDTH	SUPERFÍCIE SURFACE	CAPACIDADE MOVIMENTO MOVEMENT CAPACITY	CAPACIDADE CARGA LOAD CAPACITY
COR_101 600	Adequado para granito, mármore, Betão etc Suitable for granite, marble, concrete etc	100	139	70	590	TPV + Aço inoxidável TPV + Stainless steel	± 30	15 Ton 6 Ton
COR_101 600 SS	Adequado para granito, mármore com superfície superior em aço inoxidável Suitable for granite, marble with stainless steel top surface	100	139	70	590	Aço inoxidável Stainless steel	± 30	15 Ton 6 Ton
COR_150 600	Adequado para granito, mármore, Betão etc Suitable for granite, marble, concrete etc	150	184	70	630	TPV + Aço inoxidável TPV + Stainless steel	± 50	15 Ton 6 Ton
COR_150 600 SS	Adequado para granito, mármore com superfície superior em aço inoxidável Suitable for granite, marble with stainless steel top surface	150	184	70	630	Aço inoxidável Stainless steel	± 50	15 Ton 6 Ton
COR_200 600	Adequado para granito, mármore, Betão etc Suitable for granite, marble, concrete etc	200	234	70	680	TPV + Aço inoxidável TPV + Stainless steel	± 50	9 Ton 3,5 Ton
COR_200 600 SS	Adequado para granito, mármore com superfície superior em aço inoxidável Suitable for granite, marble with stainless steel top surface	200	234	70	680	Aço inoxidável Stainless steel	± 50	9 Ton 3,5 Ton

Juntas de dilatação totalmente estanques de embutir
Flush mounted floor completely watertight expansion joint profiles



Juntas de dilatação
estanques
Complete watertight
expansion joint profiles

» COR 100_600

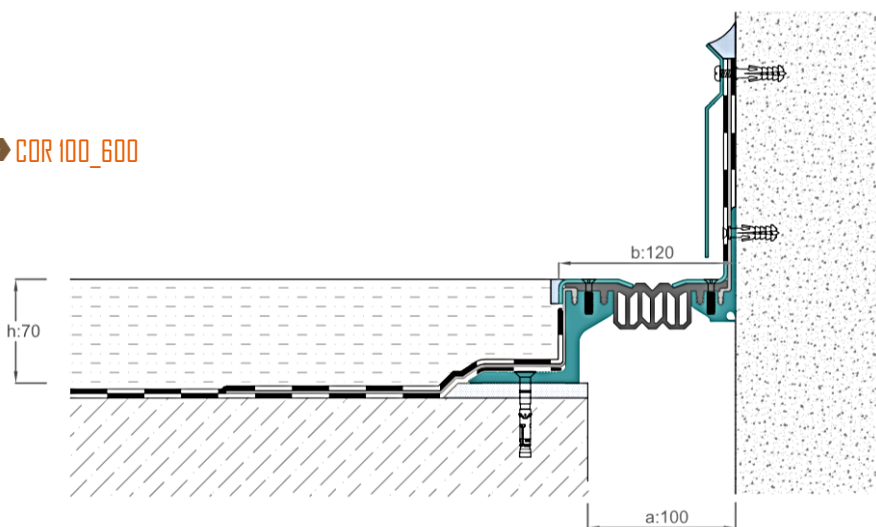

» COR 100_600

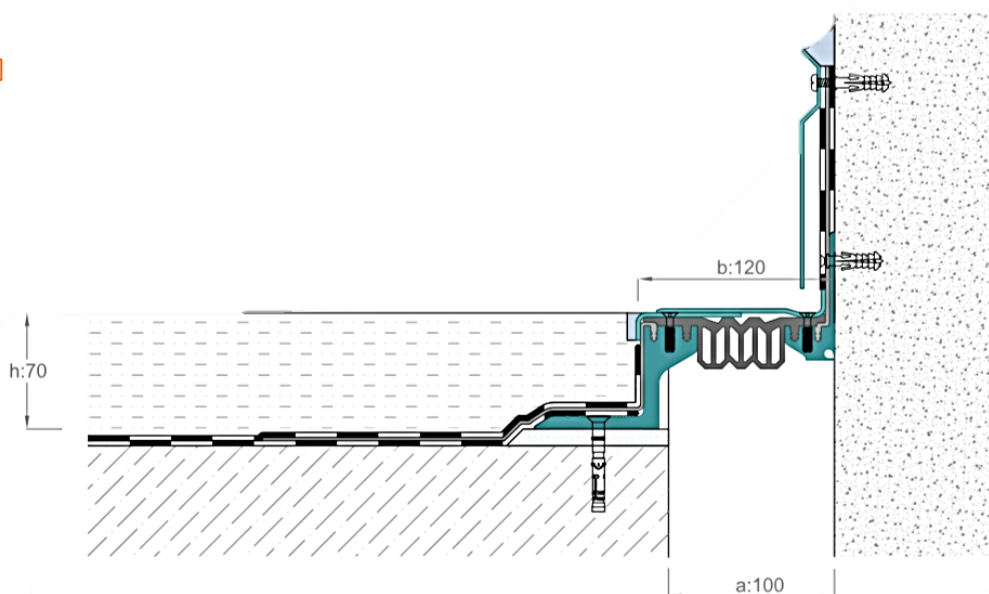

Juntas de dilatação totalmente estanques de embutir
Flush mounted floor completely watertight expansion joint profiles

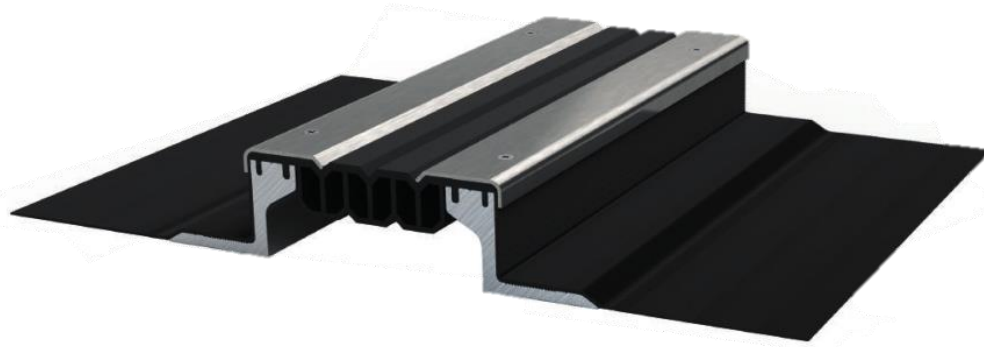

» COR 150_600

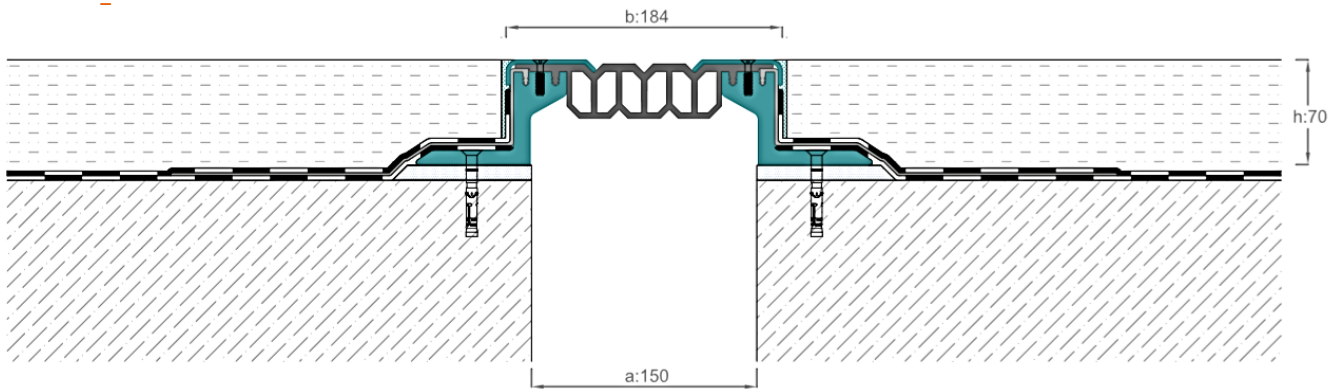

» COR 150_600 SS

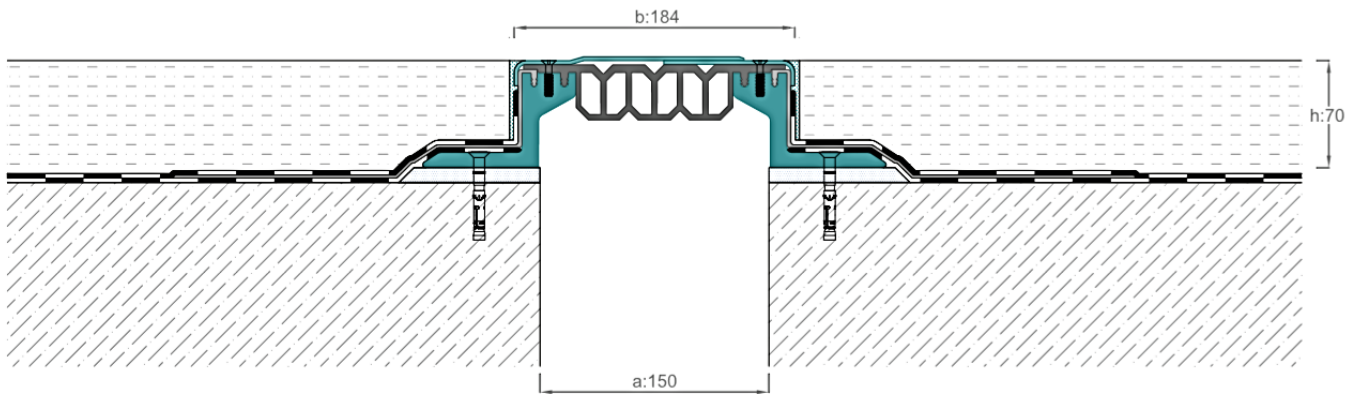

Juntas de dilatação
estanques
Complete watertight
expansion joint profiles

As juntas montadas no pavimento e as juntas de dilatação completamente estanques são adequados para intervalos de 15 cm e resistentes a cargas pesadas, com uma inserção especial de TPE no meio. Elas podem ser confortavelmente utilizadas em áreas abertas e fechadas. A conexão dos detalhes T e L também está disponível.

Flush mounted floor and completely watertight expansion joint profiles are suitable for 15cm gaps and resistant to heavy loads by having special TPE insert in the middle. They can comfortably be used in open and closed areas. Connection of T and L details are also available.



Juntas de dilatação totalmente estanques de embutir
Flush mounted floor completely watertight expansion joint profiles



Juntas de dilatação
estanques
Complete watertight
expansion joint profiles

» COR 150_600 K

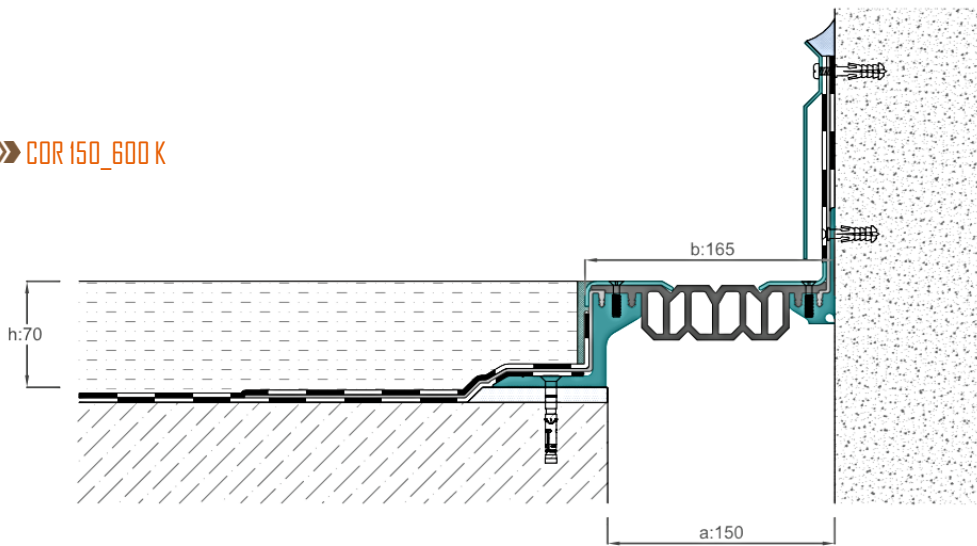

» COR 150_600 SSK

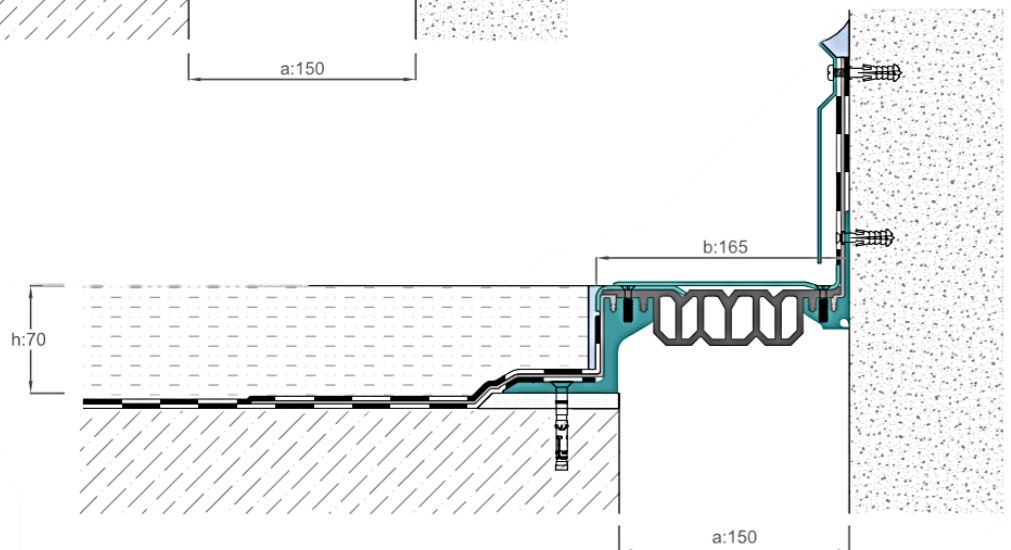

Bits adicionais podem ser derretidos usando apenas suprimento de ar quente e não requer nenhuma outra fonte extra.
Additional bits can be melted by only using hot air supply and does not require any other extra source

Bandas de juntas de dilatação termoplásticas
Thermoplastic expansion joints bands

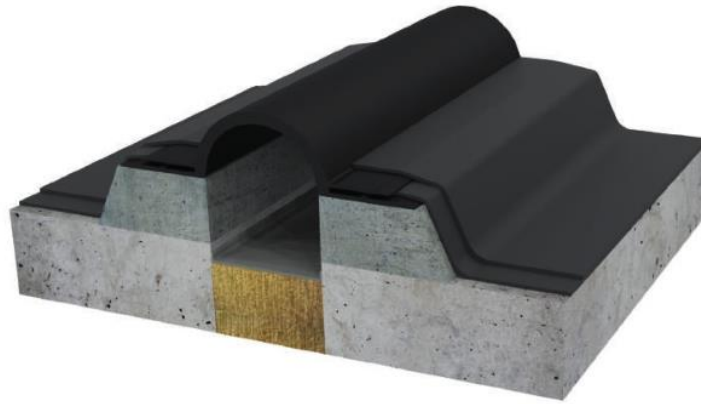

» COR 101_500

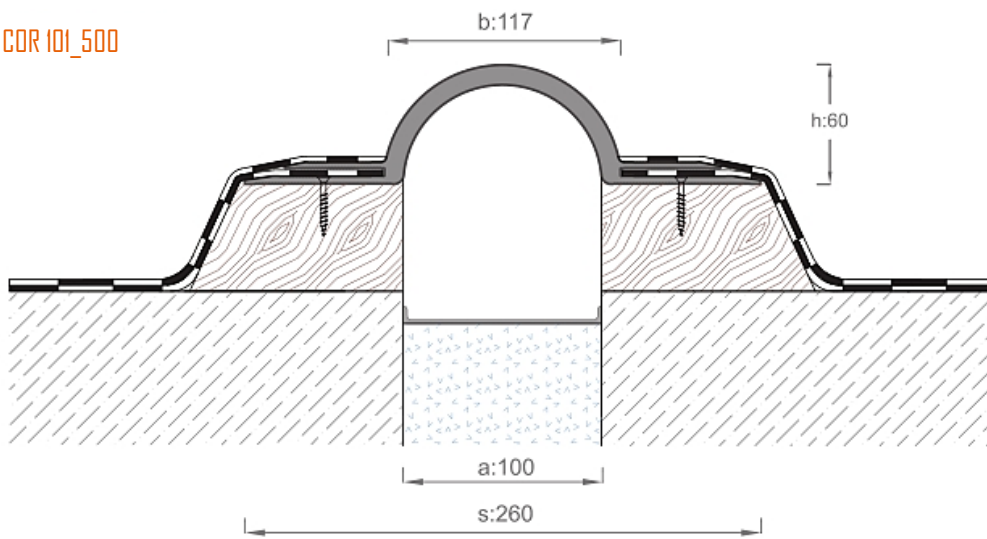

Juntas de dilatação
estanques
Complete watertight
expansion joint profiles

» COR 101_500
Detalhe de canto / Corner detail

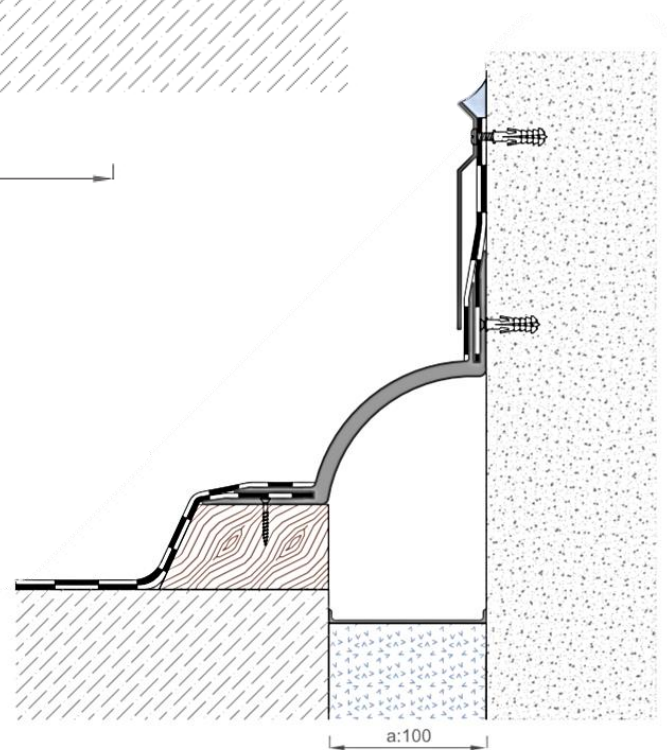

As bandas termoplásticas de terraço omega com 10 mm de espessura são resistentes a impactos e riscos de rutura com sua parte central forte. produzido em comprimentos de 15 metros.
10mm thick omega terrace thermoplastic bands are resistant to impacts and tearing risks with its strong middle part. produced in 15 meter lengths.



Bandas de juntas de dilatação termoplásticas e faixas estanques de PVC
Thermoplastic expansion joints bands and PVC watertight bands

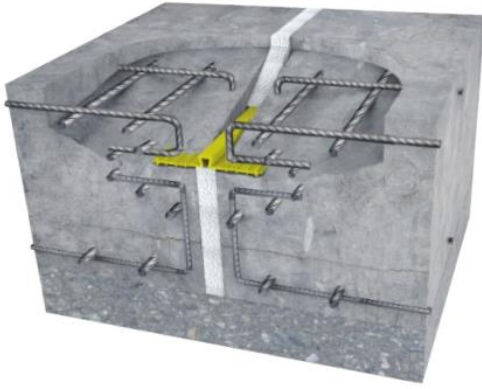

» COR 030_500

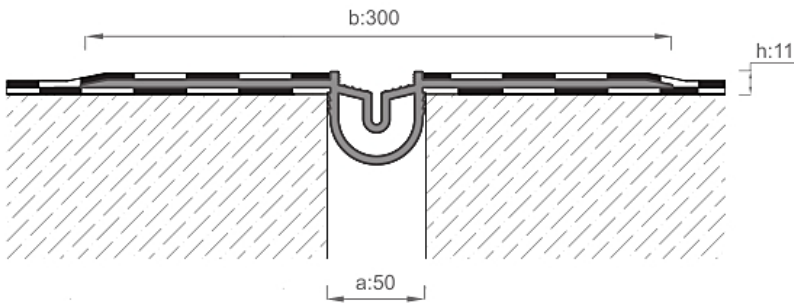

Perfis completos de juntas de dilatação estanques
 Complete watertight expansion joint profiles

» COR 20-5 - I

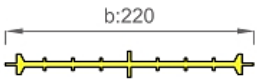

» COR 20-3/4 - AK

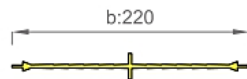

» COR 20-5 - A

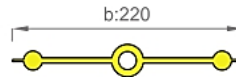

» COR 25-4 - M

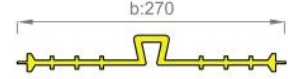

» COR 25-5 - O

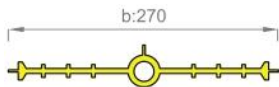

» COR 25-5 - DO



» COR 100-50 - T

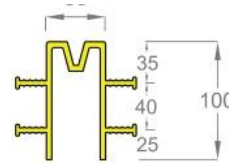

» COR 140-50 - T

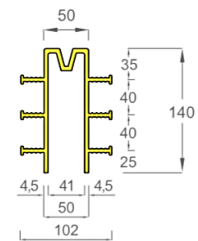

As nossas bandas estanques dimensionadas e de tipo diferente são adequadas aos padrões internacionais. Utilizado na fundação para muro de contenção, fundação para fundação e muro de contenção para muro de contenção. Entregue com 25 metros de comprimento em rolo.

Our different type and dimensioned watertight bands are suitable for international standards. Utilized in foundation to retaining wall, foundation to foundation and retaining wall to retaining wall. Delivered in 25 meters length as a roll.



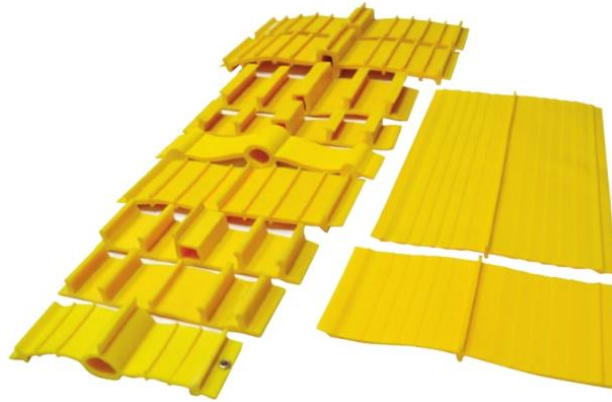

Objetivo do uso: por várias razões (assentamentos, terremotos e etc.), muitas estruturas enfrentam lacunas horizontais ou verticais. Para manter a estanqueidade nessas lacunas, são aplicadas bandas de PVC à prova de água

Purpose of use: for several reasons (settlement, earthquake etc.) many structures face with horizontal or vertical gaps. To maintain water tightness in these gaps PVC watertight bands are applied.

Material: extrudado mantendo a temperatura e pressão apropriadas usando a mistura de resina de cloreto de polivinila (PVC), vários catalisadores, estabilizador, antioxidantes, mancha, endurecedor e plastificante.

Material: Extruded by maintaining appropriate temperature and pressure using mixture of polyvinyl chloride (PVC) resin, various catalysts, stabilizer, antioxidants, stain, hardener and plasticizer.

» Áreas de aplicação / Application areas

Usinas hidráulicas, pontes, construções subterrâneas, viadutos, paredes de retenção, pisos e bases sentados no chão, centrais hidráulicas, água subterrânea abaixo do nível da água subterrânea, drenagem, reservatórios de água, instalações de tratamento de água, piscinas, lagos/lagoas, composições de cortinas, construções industriais.

Hydraulic power plants, bridges, underground constructions, viaducts, retaining walls, flooring and bases sitting on the ground, hydraulic power stations, underground water below the groundwater level, drainage, water reservoirs, water treatment facilities, swimming pools, waterfalls, curtain compositions, industrial constructions.

» Especificações técnicas / Technical specification

<i>Resistência à tração / Tensile strength</i>	<i>Valor médio Average value</i>	<i>Min. 14</i>	<i>N/mm2</i>
	<i>O menor valor The smallest value</i>	<i>Min. 12</i>	<i>N/mm2</i>
<i>Capacidade de alojamento/ stretching capacity</i>	<i>Valor médio Average value</i>	<i>Min. 225</i>	<i>%</i>
	<i>O valor menor The smallest value</i>	<i>Min.200</i>	<i>%</i>
<i>Digite um grau de dureza de durômetro de costa Type a shore durometer hardness grade</i>		<i>75±5</i>	<i>Costa "A" Shore "A"</i>
<i>Volume unitário de massa (densidade) Unit volume of mass (density)</i>		<i>1.27+0.04</i>	<i>g/cm3</i>
<i>Proporção de absorção de massa em água Mass to water absorption ratio</i>		<i>Max. 1.5</i>	<i>%</i>
<i>Sutura relação massa/cinza Mass to ash ratio suture</i>		<i>Max. 5.0 (m/m)</i>	<i>%</i>

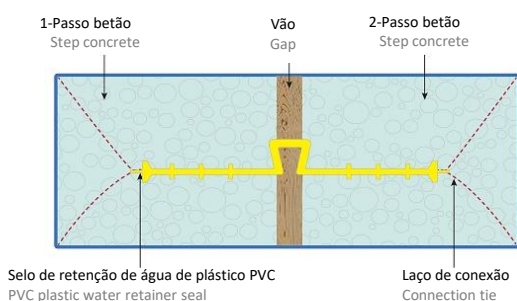

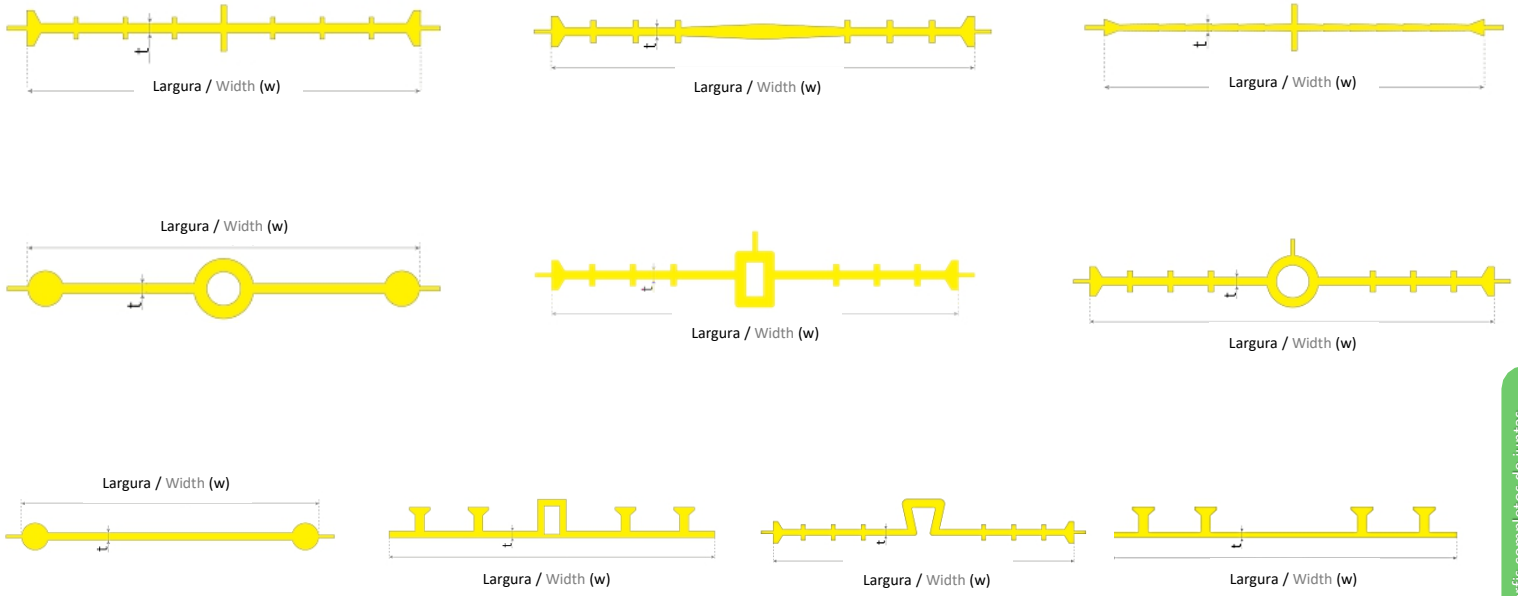

Perfis completos de juntas de dilatação estanques
Complete watertight expansion joint profiles

Tipo / Type	Largura / Width	15	15	15	15	15	15	20	20	23	23	25	25	25	30	30	30	30	35	35	40	40	50	50		
A	Espessura / Thickness	4	5	6	7	8	10	5	7	7	10	6	8	10	6	7	9	10	8	10	10	12	10	12		
B	Largura / Width	10	10	15	15	15	15	20	20	20	23	25	25	25	25	30	30	30	35	35	35	40	40			
	Espessura / Thickness	4	6	5	7	8	10	6	8	10	10	5	6	8	10	6	8	10	6	8	10	10	12			
I	Largura / Width	10	10	10	15	15	15	20	20	20	20	25	25	25	25	30	30	30	30	30	32	35	32			
	Espessura / Thickness	3	4	5	3	4	5	4	5	6	8	4	5	6	8	4	5	6	7	8	6	8	10			
OL	Largura / Width	20	20	20	25	25	25	25	30	30	30	30	32	32	32	35	35	35	40	40	40	50	50	50		
	Espessura / Thickness	5	6	7	5	6	7	8	7	8	9	10	5	8	10	8	9	10	8	10	12	8	10	12		
M	Largura / Width	15	15	15	20	20	20	20	25	25	25	25	25	30	30	30	32	32	32	35	35	35	35	40	40	40
	Espessura / Thickness	3	4	5	4	5	6	8	4	5	6	8	10	5	6	7	6	8	10	6	7	8	10	8	10	12
V	Largura / Width	10	10	10	15	15	15	20	20	20	20	20	25	25	25	25	30	30	30	30	35	35	35			
	Espessura / Thickness	3	4	5	3	4	5	4	5	6	7	8	4	5	6	8	4	5	6	8	6	8	10			
DT	Largura / Width	15	15	20	20	20	25	25	25	25	30	30	30	35	35	35	40	40	40							
	Espessura / Thickness	3	5	4	6	8	4	5	6	8	4	6	8	4	6	8	6	8	10							
DO	Largura / Width	15	15	20	20	20	25	25	25	25	30	30	30	35	35	35	40	40	40							
	Espessura / Thickness	3	5	4	6	8	4	5	6	8	4	6	8	4	6	8	6	8	10							
DI	Largura / Width	15	15	20	20	20	25	25	25	30	30	30	35	35	35	40	40	40								
	Espessura / Thickness	3	4	5	6	8	4	6	8	4	6	8	4	6	8	6	8	10								
O	Largura / Width	15	15	15	20	20	20	22	22	22	26	26	26	30	30	30	32	32	32							
	Espessura / Thickness	3	4	5	3	4	5	4	5	6	4	5	6	4	5	6	4	5	6							
AK	Largura / Width	15	15	15	20	20	20	24	24	24	24															
	Espessura / Thickness	3	4	5	3	4	5	3	4	5	6															

Bandas de juntas de dilatação termoplásticas e faixas estanques de PVC
 Thermoplastic expansion joints bands and PVC watertight bands

» COR 100_605

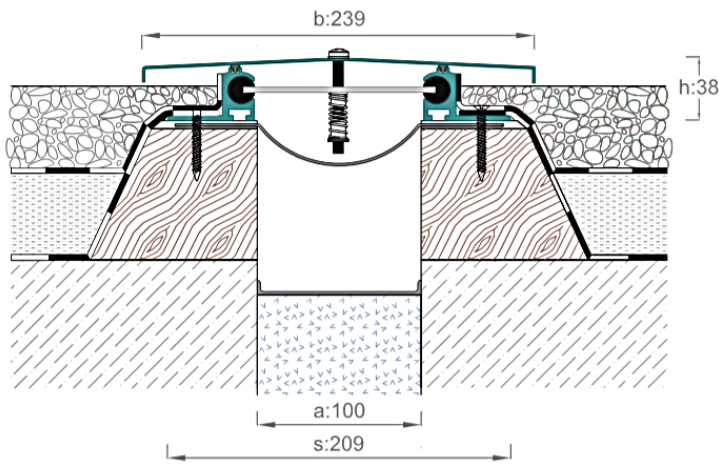

» COR 100K_605

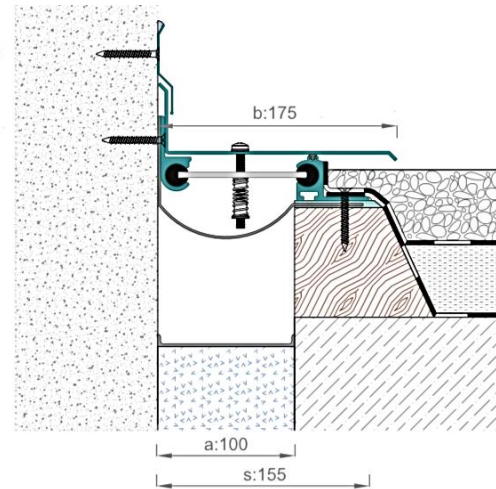
 Perfis completos de juntas de dilatação estanques
 Complete watertight expansion joint profiles

As juntas de dilatação de terraço, são usados como protetores e isoladores em terraços abertos. Aplicado com calços de madeira absorvidos betume ou cimento de dilatação. Os perfis H são montados em locais adicionais para obter uma estanqueidade completa.

Coping type terrace expansion joint profiles are used as protectors and isolators in opened terraces. Applied with bitumen absorbed wooden wedges or dilatation concrete. H profiles are fitted in additional places to achieve complete water tightness.



REF	DESCRIÇÃO DESCRIPTION	LARGURA DA JUNTA (a) mm JOINT WIDTH	SUPERFÍCIE VISÍVEL (b) mm SURFACE VISIBLE	ALTURA (h) mm PROFILE HEIGHT	LARGURA (s) mm TOTAL WIDTH	SUPERFÍCIE SURFACE	CAPACIDADE MOVIMENTO mm MOVEMENT CAPACITY
COR_050_605	juntas de revestimento para aplicações em terraço Coping profiles for terrace applications	50	189	38	189	Alumínio Anodizado / Tinta revistida a pó Anodized aluminum / Powder coated paint	+25
COR_100_605	juntas de revestimento para aplicações em terraço Coping profiles for terrace applications	100	239	38	239	Alumínio Anodizado / Tinta revistida a pó Anodized aluminum / Powder coated paint	+50
COR_150_605	juntas de revestimento para aplicações em terraço Coping profiles for terrace applications	150	289	38	289	Alumínio Anodizado / Tinta revistida a pó Anodized aluminum / Powder coated paint	+75
COR_200_605	juntas de revestimento para aplicações em terraço Coping profiles for terrace applications	200	339	38	339	Alumínio Anodizado / Tinta revistida a pó Anodized aluminum / Powder coated paint	+100
COR_250_605	juntas de revestimento para aplicações em terraço Coping profiles for terrace applications	250	389	38	389	Alumínio Anodizado / Tinta revistida a pó Anodized aluminum / Powder coated paint	+100
COR_300_605	juntas de revestimento para aplicações em terraço Coping profiles for terrace applications	300	439	38	439	Alumínio Anodizado / Tinta revistida a pó Anodized aluminum / Powder coated paint	+100



» COR 10I_605

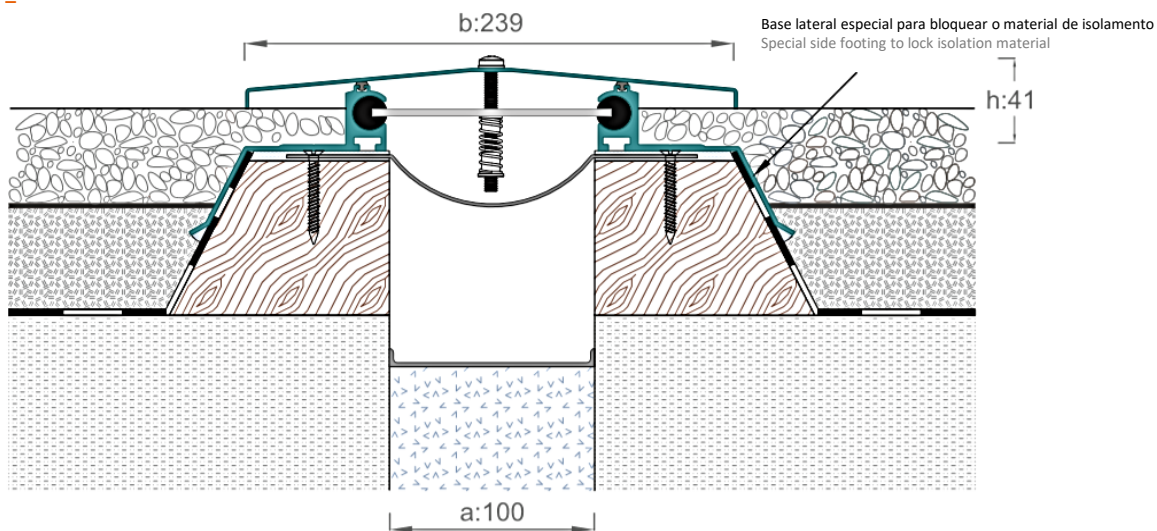

Perfis completos de juntas de dilatação estanques
Complete watertight expansion joint profiles

» COR 10IK_605

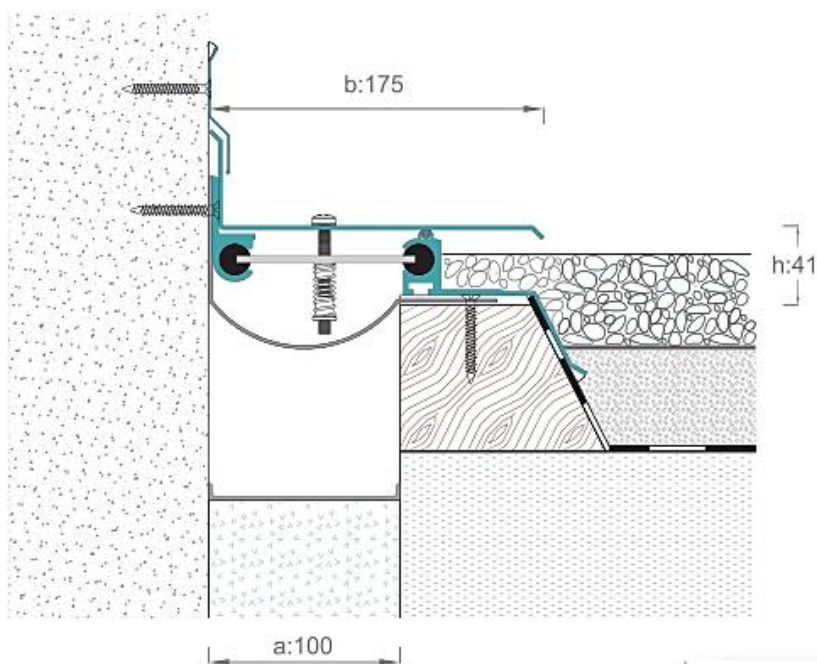

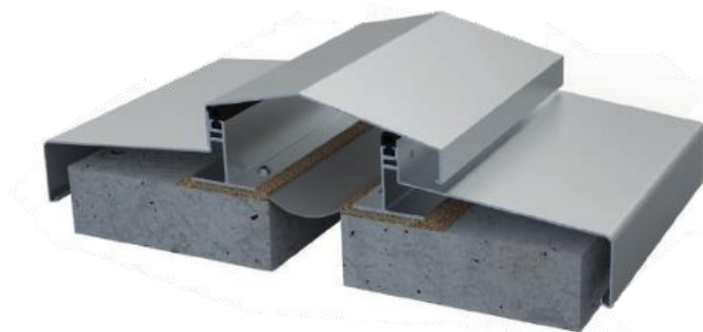

» COR 050_606

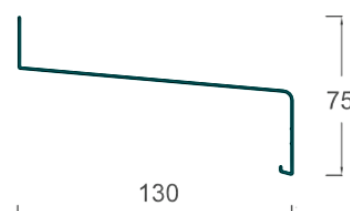
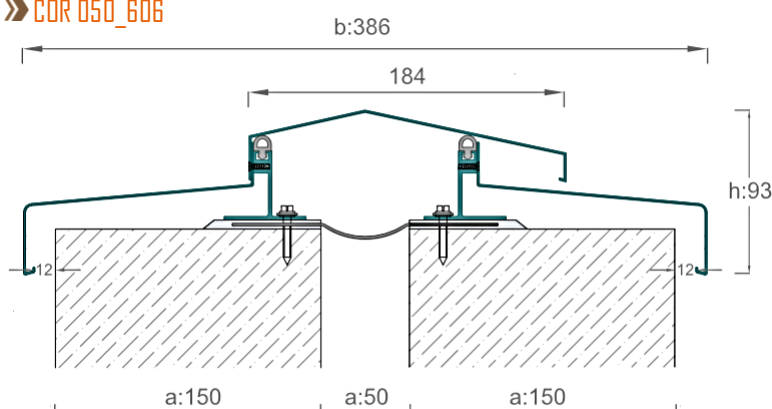

COR 050_606 15CM PARAPEITO / PARAPET

» COR 050K_606

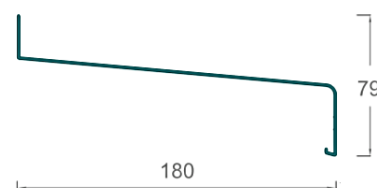
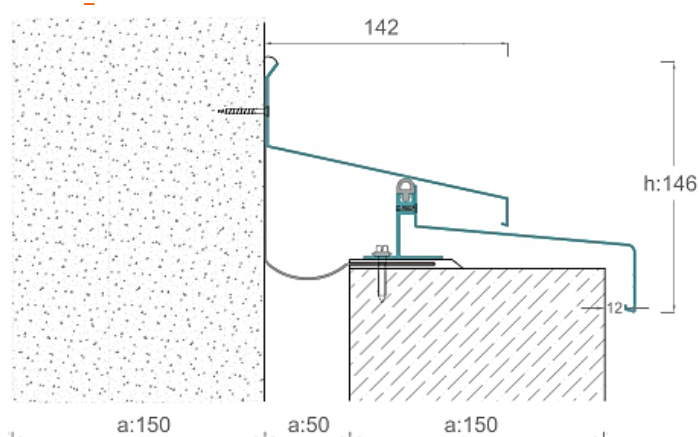

COR 051_606 20CM PARAPEITO / PARAPET

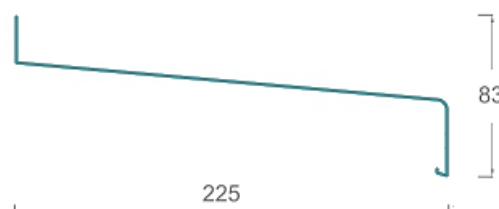

COR 052_606 25CM PARAPEITO / PARAPET

 Perfis completos de juntas
 de dilatação estanques
 Complete watertight
 expansion joint profiles

As juntas de cobertura do terraço podem ser produzidas de acordo com as dimensões da folga. A estanqueidade pode ser obtida pelo perfil TPE H.
 Terrace coping profiles bottom footing can be produced according to the gap dimensions. Water tightness can be obtained by TPE H profile.

REF	DESCRIÇÃO DESCRIPTION	LARGURA DA JUNTA (a) mm JOINT WIDTH	SUPERFÍCIE VISÍVEL (b) mm SURFACE VISIBLE	ALTURA (h) mm PROFILE HEIGHT	LARGURA (s) mm TOTAL WIDTH	SUPERFÍCIE SURFACE	CAPACIDADE MOVIMENTO mm MOVEMENT CAPACITY
COR_050_606	Juntas de revestimento para aplicações em terraço Coping profiles for terrace applications	50	386	93	386	Alumínio Anodizado / Tinta revistida a pó Anodized aluminum / Powder coated paint	+25
COR_100_606	Juntas de revestimento para aplicações em terraço Coping profiles for terrace applications	100	436	93	436	Alumínio Anodizado / Tinta revistida a pó Anodized aluminum / Powder coated paint	+50
COR_150_606	Juntas de revestimento para aplicações em terraço Coping profiles for terrace applications	150	486	93	486	Alumínio Anodizado / Tinta revistida a pó Anodized aluminum / Powder coated paint	+50
COR_200_606	Juntas de revestimento para aplicações em terraço Coping profiles for terrace applications	200	536	93	536	Alumínio Anodizado / Tinta revistida a pó Anodized aluminum / Powder coated paint	+50
COR_250_606	Juntas de revestimento para aplicações em terraço Coping profiles for terrace applications	250	586	93	586	Alumínio Anodizado / Tinta revistida a pó Anodized aluminum / Powder coated paint	+50
COR_300_606	Juntas de revestimento para aplicações em terraço Coping profiles for terrace applications	300	636	93	636	Alumínio Anodizado / Tinta revistida a pó Anodized aluminum / Powder coated paint	+50

Juntas de movimento
Movement joint profiles

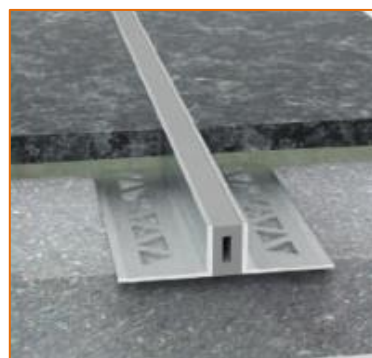
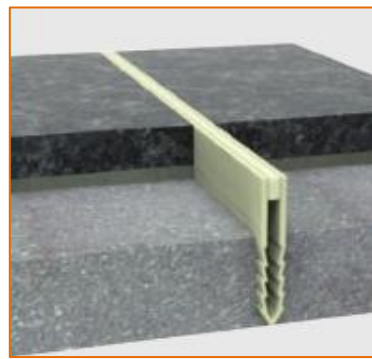

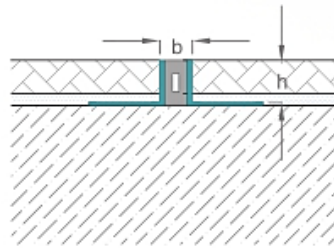

>> COR 01_06 DP

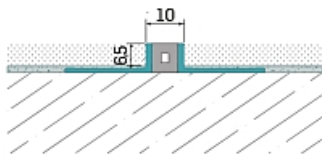

>> COR 01_08 DP

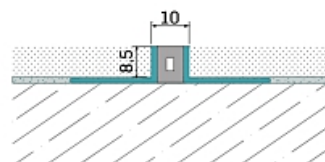

>> COR 01_10 DP

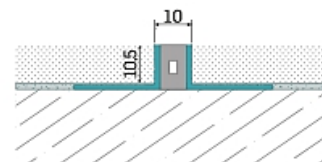

>> COR 01_12 DP

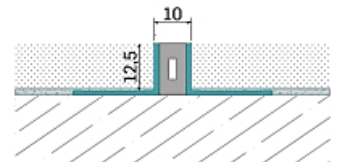

>> PORQUE RAZÃO AS JUNTAS DE MOVIMENTO SÃO USADAS? / WHY MOVEMENT JOINT PROFILES ARE USED ?

As aplicações em cerâmica, granito, porcelana, pedra, cerâmica vítrea, betão e mármore e revestimentos de terrazzo exigem juntas de dilatação térmica para absorver movimentos naturais. A diferença de temperatura causa expansão e encolhimento em revestimentos de água ou umidade, portanto, todos os ladrilhos encolhem com a secagem e resfriamento. Outro motivo, cargas estruturais dinâmicas causam vibrações e grandes movimentos nas aplicações de ladrilhos. Se a junta de dilatação não for usada em aplicações de azulejos, cerâmica, granito ou mármore, as tensões internas devido à expansão ou contração interna podem causar muitos problemas, como rachaduras e quebras óbvias. Portanto, o design de junta extremamente significativo para a vida útil dos revestimentos.

Ceramic, granite, porcelain, stone, glassy ceramics, concrete and marble tiles and terrazzo floor cover applications require thermal expansion joints profiles to absorb natural movements. The temperature difference causes expansion and shrinkage in water or moisture coatings thus, all the tiles shrink with drying and cooling. Another reason, dynamic, structural loads cause vibration and large movements in the tile applications. If expansion joint it not used in tile, ceramic, granite or marble applications, internal stresses due to expansion or internal shrinkage can cause many problems such as, obvious cracks and breakage. Therefore, joint design extremely significant for the life of the coatings.

>> PADRÕES DE APLICAÇÃO / APPLICATION STANDARDS

Área de aplicação Application area	Área mínima de aplicação m2 Minimum application	Área máxima de aplicação m2 Maximum application	Largura da junta de movimento (broca de elastômero) Movement joint width (Elastomer bit)
Áreas internas Internal areas	4,80 mt * 4,80mt	6,00 mt * 6,00 mt	6mm
Áreas internas (áreas úmidas e iluminadas pelo sol) Internal areas (moist and sun lighted areas)	3,60 mt * 3,60 mt	4,80 mt * 4,80 mt	6mm
Áreas externas External areas	2,40 mt * 2,40 mt	3,60 mt * 3,60 mt	10mm
Áreas externas (diferenças de temperatura mais quentes e frias ≥ 40C) External areas (hottest and coldest temperature differences ≥ 40C)	2,40 mt * 2,40 mt	3,60 mt * 3,60 mt	13mm



» COR_01_14 DP

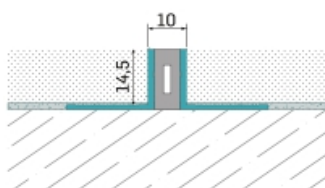

» COR_01_16 DP

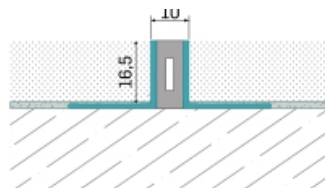

» COR_01_23 DP

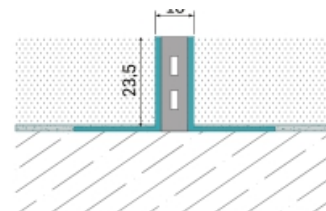

» COR_01_60 DP

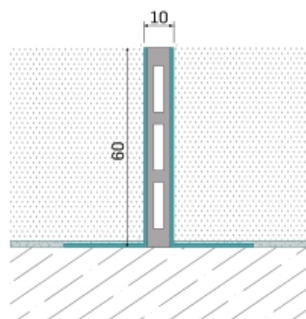

» COR_13_14 DP

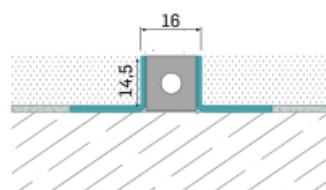

» COR_01_25 DP

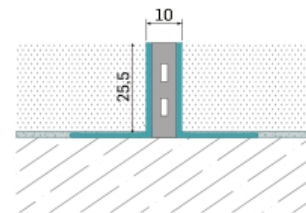

Perfis de juntas de juntas de movimento
Movement joint profiles

REF	SUPERFICIE VISIVEL (b) mm SURFACE VISIBLE	ALTURA (h) mm PROFILE HEIGHT	CAPACIDADE MOVIMENTO mm MOVEMENT CAPACITY
COR_01_06 DP	10	6,5 + 1,2	+5/-3
COR_01_08 DP	10	8,5 + 1,2	+5/-3
COR_01_10 DP	10	10,5 + 1,2	+5/-3
COR_01_12 DP	10	12,5 + 1,2	+5/-3
COR_01_14 DP	10	14,5 + 1,2	+5/-3
COR_01_16 DP	10	16,5 + 1,2	+5/-3
COR_01_23 DP	10	23,5 + 1,2	+5/-3
COR_01_25 DP	10	25,5 + 1,2	+5/-3
COR_01_60 DP	10	58,5 + 1,5	+5/-3
COR_13-14 DP	16	14,5 + 1,5	+7

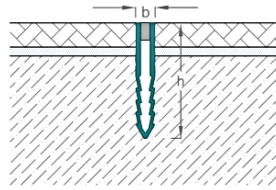
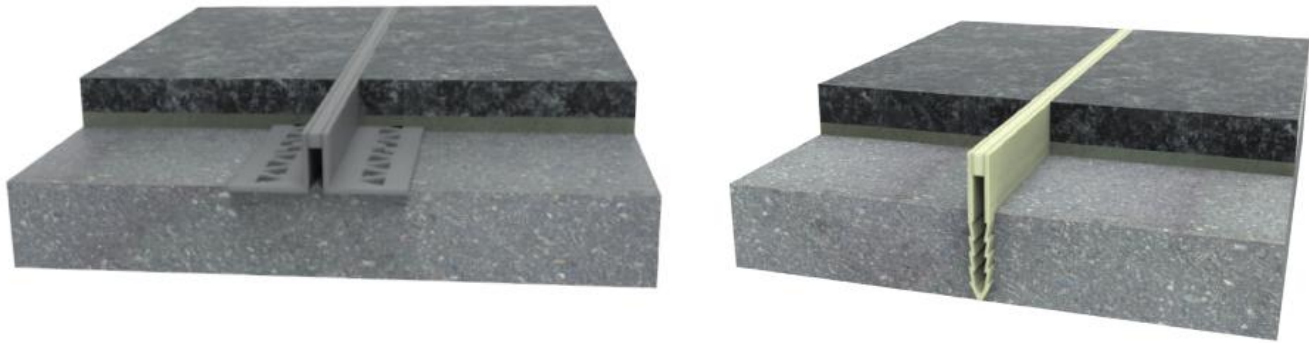

Perfis de juntas de juntas de movimento / Movement joint profiles

» COR_02_10 DP

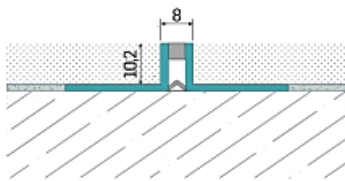

» COR_02_12 DP

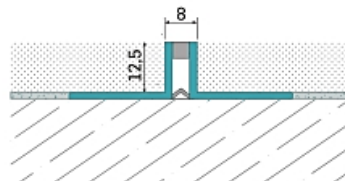

» COR_02_15 DP

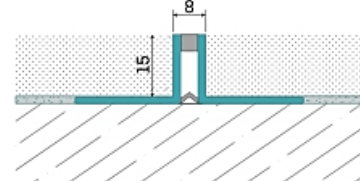

» COR_06 DP

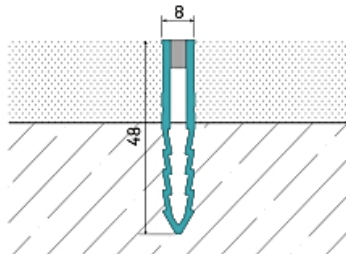

» COR_06-1 DP

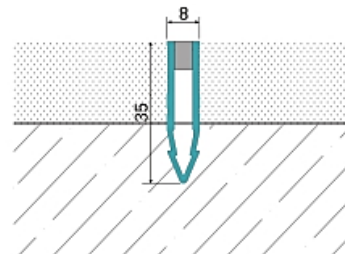

REF	SUPERFICIE VISIVEL (b) mm SURFACE VISIBLE	ALTURA (h) mm PROFILE HEIGHT	CAPACIDADE MOVIMENTO mm MOVEMENT CAPACITY
COR_02_10 DP	8	10,5 + 1,2	±2
COR_02_12 DP	8	12,5 + 1,2	±2
COR_02_15 DP	8	15 + 1,2	±2
COR_06 DP	8	48	±2
COR_06-1 DP	8	35	±2

Stainless Steel
304 Quality

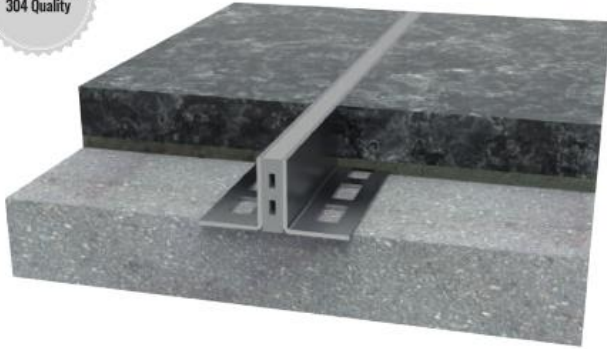

»» COR_08_12 DP

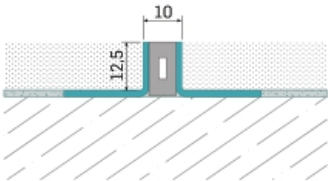

»» COR_08_14 DP

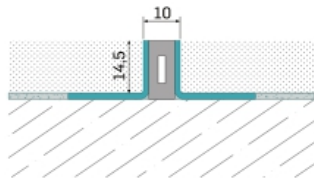

»» COR_08_16 DP

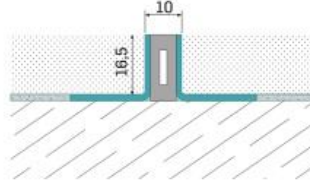

»» COR_08_23 DP

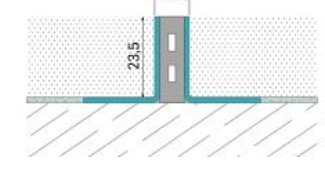

»» COR_08_30 DP

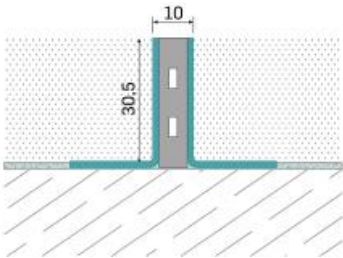

»» COR_11 DP

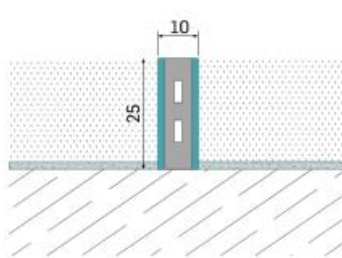

»» COR_14_14 DP

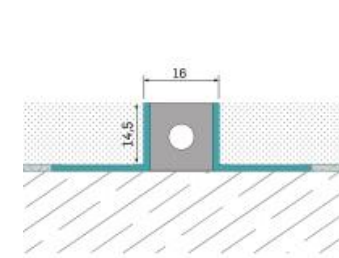

Perfis de Juntas de juntas
de movimento
Movement joint profiles



REF	SUPERFICIE VISIVEL (b) mm SURFACE VISIBLE	ALTURA (h) mm PROFILE HEIGHT	CAPACIDADE MOVIMENTO mm MOVEMENT CAPACITY
COR_08_12 DP	10	12,5 + 1,5	+5/-3
COR_08_14 DP	10	14,5 + 1,5	+5/-3
COR_08_16 DP	10	16,5 + 1,5	+5/-3
COR_08_23 DP	10	23,5 + 1,5	+5/-3
COR_08_30 DP	10	30,5 + 1,5	+5/-3
COR_11 DP	10	25	+5/-3
COR_14_14 DP	16	14,5 + 1,5	+7

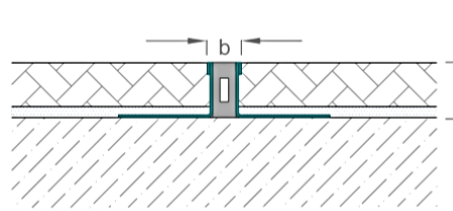
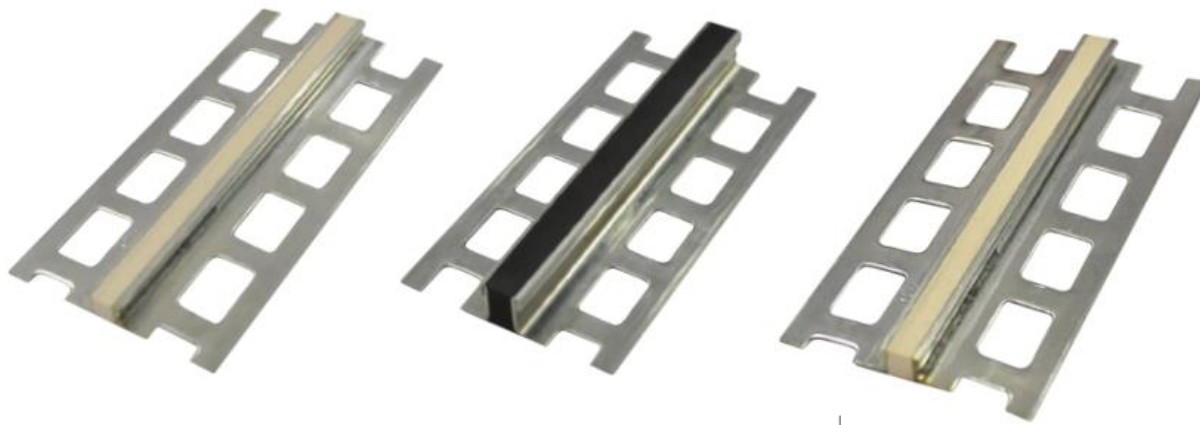

>> COR_09_04 DP

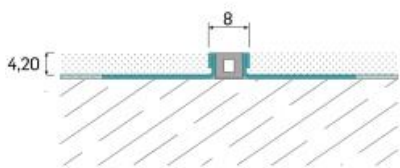

>> COR_09_06 DP

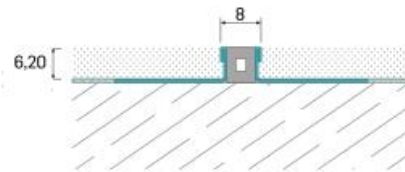

>> COR_09_08 DP

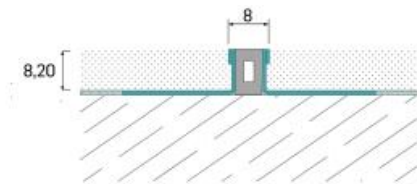

>> COR_09_10 DP

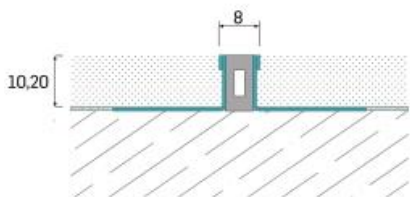

>> COR_09_12 DP

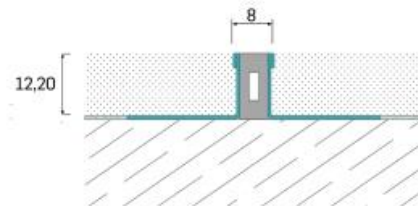

>> COR_09_20 DP

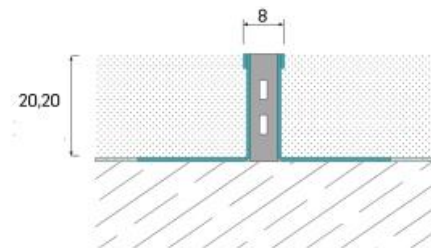

REF	SUPERFICIE VISIVEL (b) mm SURFACE VISIBLE	ALTURA (h) mm PROFILE HEIGHT	CAPACIDADE MOVIMENTO mm MOVEMENT CAPACITY
COR_09_04 DP	8	4,20 + 0,8	±5/-3
COR_09_06 DP	8	6,20 + 0,8	±5/-3
COR_09_08 DP	8	8,20 + 0,8	±5/-3
COR_09_10 DP	8	10,20 + 0,8	±5/-3
COR_09_12 DP	8	12,20 + 0,8	±5/-3
COR_09-12 DP	8	20,20 + 0,8	±5/-3

Produtos para juntas de controle de
retração e trincas
Shrinkage and crack control joint products

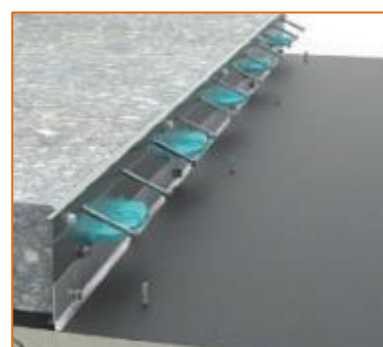
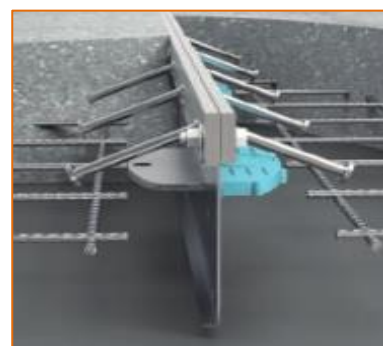
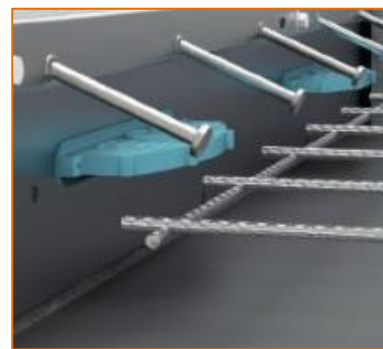

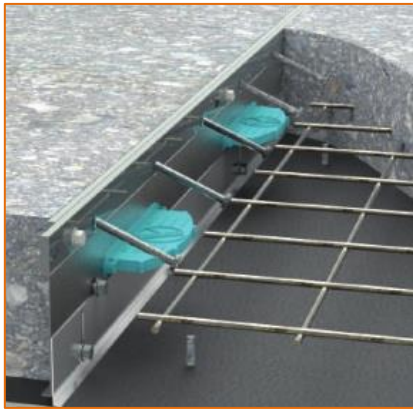

» LOGO APÓS DESPEJAR O CIMENTO
RIGHT AFTER POURING CONCRETE



» 2-3 SEMANAS APÓS O CIMENTO DERRAMADO
2-3 WEEKS AFTER POURED CONCRETE

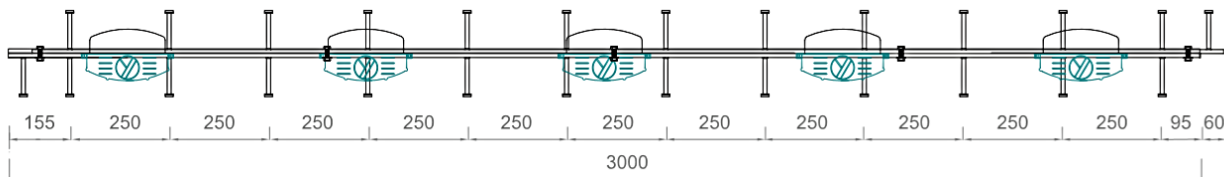

» PLANO / PLAN

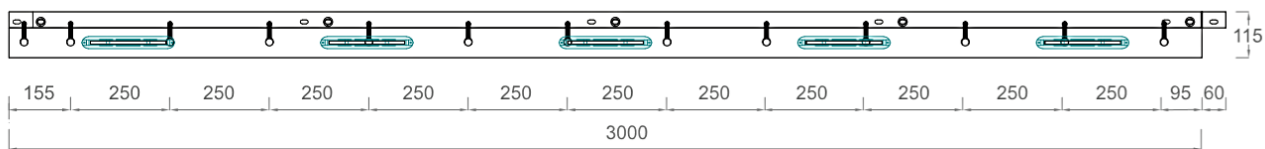

» VISTA FRONTAL / FRONT VIEW

Perfis de juntas de controle
de contração e rachadura
Shrinkage and crack control
joint profiles

As juntas de dilatação de laje são juntas de dilatação de aço que prolongam a vida útil de lajes de betão que pretendem transportar altas cargas. As juntas de laje podem ser facilmente aplicadas em pavimentos industriais para minimizar a formação descontrolada de trincas. As superfícies das juntas de laje são produzidas como aço galvanizado a quente e aço inoxidável (classe SS 304) como padrão.

Slab expansion joints are steel expansion joints that extend the service life of concrete slabs which intend to carry high loads. Slab joints can easily be applied in industrial floors to minimize uncontrolled crack formation. Slab joints surfaces are produced as hot dip galvanized steel and stainless steel (SS 304 grade) as standard.

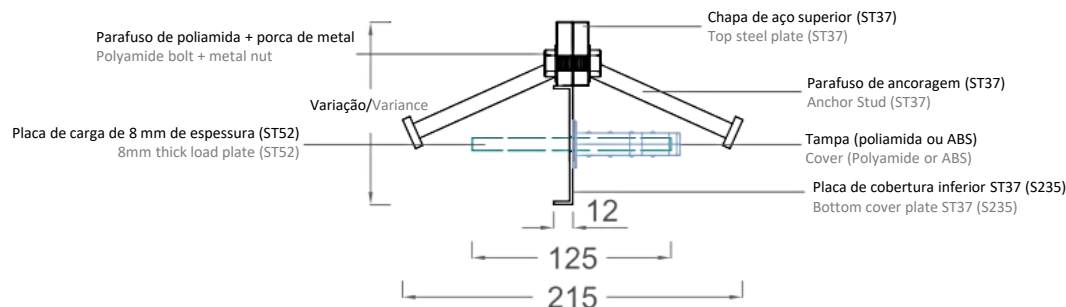

REF	COMPRIMENTO DA JUNTA DA LAJE (mm) SLAB JOINT LENGTH	ALTURA DA JUNTA DA LAJE (mm) SLAB JOINT HEIGHT	PROFUNDIDADE RECOMENDADA (mm) RECOMMENDED DEEPNESS	CENTRO DA PLACA DE CARGA CENTRE OF THE LOAD PLATE
COR_115 SJ	3000	115	115-140	600
COR_140 SJ	3000	140	140-165	600
COR_165 SJ	3000	165	165-185	600
COR_185 SJ	3000	185	185-235	600
COR_235 SJ	3000	235	235-285	600
COR_285 SJ	3000	285	285-300	600



Perfis de juntas de controle de contração e rachadura
Shrinkage and crack control joint profiles

Tradicionalmente, o betão da laje é cortado 24 horas após o betão ter sido derramado em larguras de 24 a 30 vezes a espessura do betão da laje. O encolhimento interno do betão começa a ocorrer após 4 a 18 horas, o que ocorre entre os pontos fracos do cimento e agregados.

Traditionally, the slab concrete gets cut 24 hours after the concrete, has been poured at widths of 24 to 30 times the thickness of the slab concrete. Internal shrinkage in the concrete starts happening after 4 to 18 hours which occurs in between the weak points of cement and aggregates.

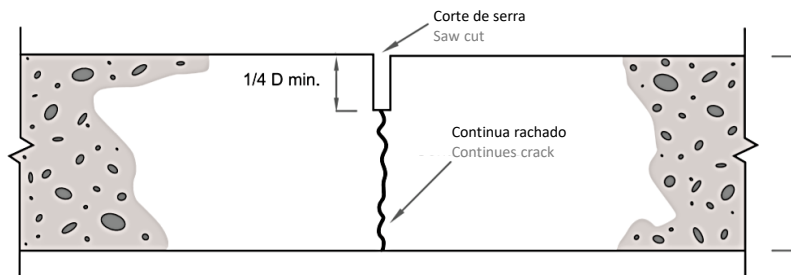

» O COMPORTAMENTO DO BETÃO DA LAJE APÓS UM CORTE / SLAB CONCRETE BEHAVIOUR AFTER A CUT

A junta da laje fornece uma folga perfeita da junta durante o vazamento do betão. Para atingir esse intervalo de linha desejado, linhas fracas são criadas são locais predeterminados para fazer trinças simétricas. Além disso, para evitar movimentos verticais e fornecer transferência de carga horizontal nessas folgas, o ST52 é utilizado em intervalos de 600 mm com placas de aço móveis de 8 mm nos rolamentos. A lacuna ocorre entre o dia 1 e a semana 3 sem exigir cortes ou moldes adicionais.

Slab joint provides a neat joint gap during concrete pouring. To achieve this desired line gap, weak lines are created are predetermined locations to make symmetric cracks. Furthermore, to prevent vertical movements and provide horizontal load transfer in these gaps, ST52 is utilized by 600mm intervals with movable 8mm steel plates in bearings. The gap then occurs between day 1 to week 3 without requiring additional cuts or molds.

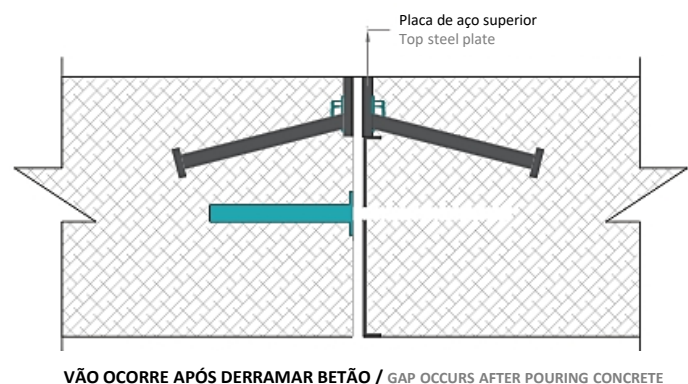
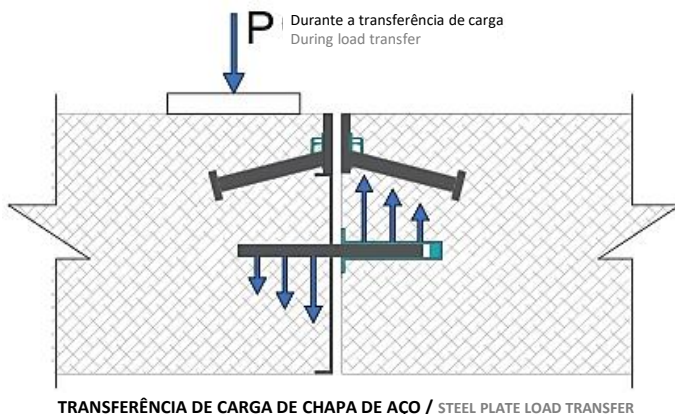

A junta da laje fornece lacunas menores que os métodos tradicionais. Também fornece intervalos de 25 a 30 m em vez de 5x5m. Isso significa que a quantidade total de lacunas é reduzida em aproximadamente 10 vezes. O American Concrete Institute (ACI) recomenda produtos de juntas de placas em vez de cortes tradicionais.

Slab joint provides smaller gaps than traditional methods. Also provides 25m to 30m interval gaps instead of 5x5m. This means the total quantity of gaps reduce by approximately 10 times. American concrete institute (ACI) recommends slab joint products instead of traditional cuts.



Perfis de juntas de controle
de contração e rachadura
Shrinkage and crack control
joint profiles

Existem duas estratégias de prevenção de rachaduras na superfície do betão:

- 1- Aumente a quantidade de reforço de aço para evitar rachaduras aleatórias. Quando as trincas são reforçadas firmemente pelo aço, as peças agregadas transferem a carga do outro lado das pequenas trincas. Portanto, a carga fica uniformemente distribuída. No entanto, o uso de muito reforço de aço na laje de betão pode criar uma visão desagradável da malha de aço na superfície superior.
- 2 - A maneira mais comum é usar produtos de controle de dilatação e retração. Dessa forma, as trincas são forçadas a ocorrer em um local como uma linha firme, portanto a vista na superfície parece muito mais decorativa.

Os produtos industriais de controle de dilatação e contração minimizam as rachaduras inesperadas e são capazes de transportar cargas pesadas. Adequado para lajes industriais e lajes de betão.

Rachaduras inesperadas são evitadas com a lacuna de isolamento ao redor das colunas.

There are two strategies of preventing cracks on concrete surface:

- 1- Increase steel reinforcement amount to avoid random cracks. When cracks are firmly reinforced by steel, aggregate pieces transfer the load on other side of the small cracks. So the load gets evenly distributed. However, using too much steel reinforcement in concrete slab can create unpleasant view of the steel mesh on the top surface.
- 2 - The most common way is to use expansion and shrinkage control products. By this way, cracks are forced to occur in one place as a firm line thus the view on the surface looks much more decorative.

Industrial expansion and shrinkage control products minimize the unexpected cracks and can carry heavy loads. Suitable for industrial slabs and concrete slabs.

Unexpected cracks are prevented with the isolation gap around the columns.



Barreiras contra incêndio e água
Fire and water barriers

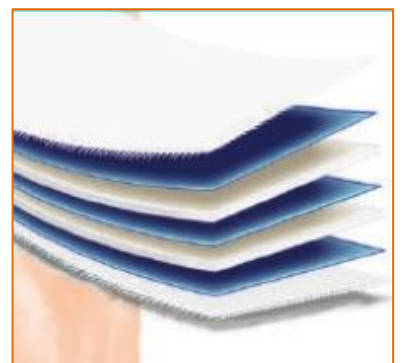

» MANTA DE INCÊNDIO CORTA-FOGO 120 / FIRESTOP 120 FIRE BLANKET

- ✓ Em várias larguras (FS100, FS150, FS200, FS250.FS300) / At various widths (FS100,FS150,FS200,FS250.FS300)
- ✓ Adequado para juntas de dilatação de 10cm a 40cm / Suitable to expansion joint gaps from 10cm to 40cm
- ✓ Facilmente aplicável / Easily applicable
- ✓ Perfil de montagem galvanizado / Galvanized assembly profile
- ✓ Testado de acordo com a BS 476: Parte 20/22 / Tested according to BS 476: Part 20/22
- ✓ Ativo em 120 minutos / Active on 120 minutes
- ✓ Impedindo a transferência de calor por 30 minutos / Preventing heat transfer for 30 minutes
- ✓ Comprimento de produção é de 7 metros / Production length is 7 meter

O Firestop 120 é um cobertor anti-fogo de fibra de vidro de 7 camadas, de alto desempenho e baixo peso, projetado para impedir a passagem de fogo e fumaça nas folgas das juntas de dilatação e também impede a transferência de calor e a transição da chama para o lado frio.

Firestop 120 is a high performance, low weight, 7 layer fiberglass fire blanket that is designed to prevent fire and smoke passage in expansion joint gaps and also prevents heat transfer and flame transition to cold side.



30 Minutos de isolamento
Minutes isolation

120 Minutos de integridade
Minutes of integrity

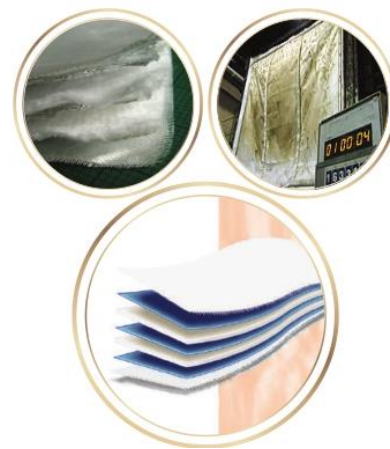
 Barreira contra incêndio e água
 Fire and water barrier

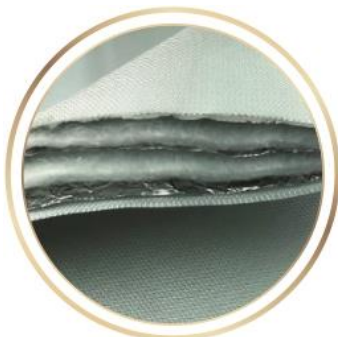
» MANTA DE INCÊNDIO CORTA - DETALHE DA UNIÃO / FIRE BLANKET - JOINING DETAIL

Pode ser facilmente aplicado com um grameador
 Can easily be applied a stapler

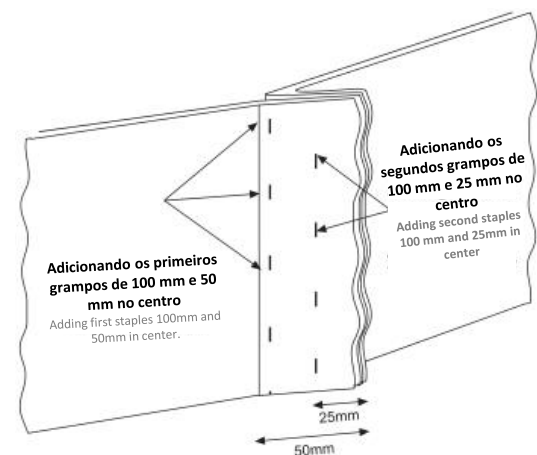



» Aplicação de barreira corta-fogo sob perfil de junta de dilatação /
 Fire barrier application under expansion joint profile

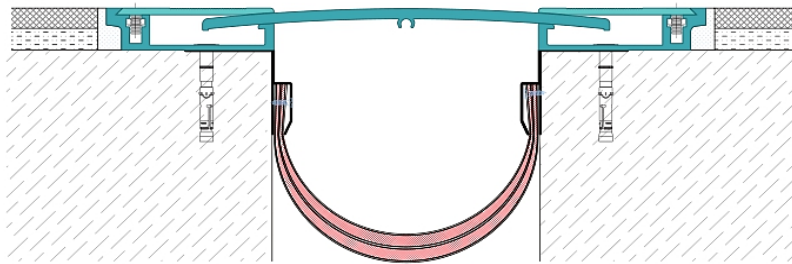

As Barreiras contra incêndio podem ser aplicadas mais fácil e rapidamente do que as soluções tradicionais. As barreiras corta-fogo foram projetadas e testadas para resistir ao fogo por mais tempo quando montadas corretamente.

Pode ser usado em intervalos verticais e horizontais de 100 mm a 400 mm. Adequado para aplicações de piso e parede. Spray líquido adicional pode ser usado para evitar a fumaça do incêndio.

Áreas de aplicação: Estacionamentos, hospitais, centros comerciais, escolas, bibliotecas e etc.

Fire barriers can be applied easier and faster than traditional solutions. Fire barriers have designed and tested to resist fire longest when mounted properly.

Can be used in vertical and horizontal gaps from 100mm to 400mm. Suitable for floor and wall applications. Additional liquid spray can be used to prevent fire smoke.

Application areas: Carparks, hospitals, shopping centres, schools, library and etc.

» Aplicação de barreira corta-fogo /

Fire barrier application

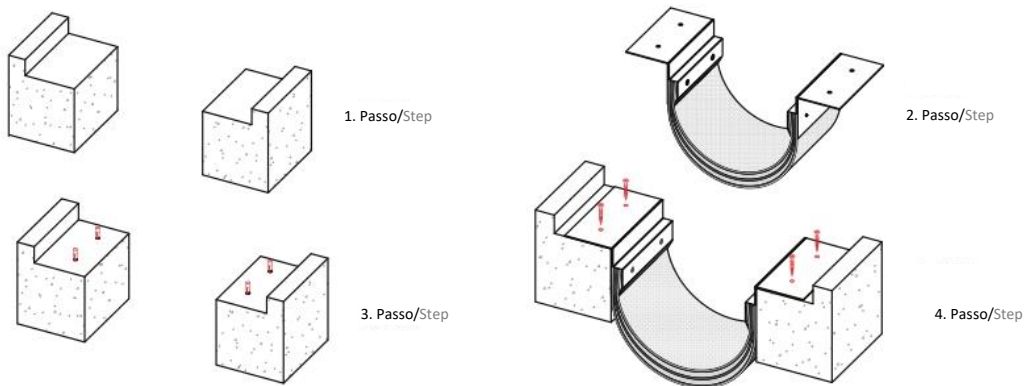

Barreira contra incêndio e água
 Fire and water barrier

-Pré-montado nos perfis de aço / Preassembled to the steel profiles

REF	DESCRIÇÃO DESCRIPTION	LARGURA DA BARREIRA BARRIER WIDTH	COMPRIMENTO (METRO/METER) LENGTH
COR_50 FS	Aplicado a juntas de dilatação de 50mm Applied to 50mm expansion joint gaps	135	7,00
COR_100 FS	Aplicado a juntas de dilatação de 100mm Applied to 100mm expansion joint gaps	216	7,00
COR_150 FS	Aplicado a juntas de dilatação de 150mm Applied to 150mm expansion joint gaps	285	7,00
COR_200 FS	Aplicado a juntas de dilatação de 200mm Applied to 200mm expansion joint gaps	360	7,00
COR_250 FS	Aplicado a juntas de dilatação de 250mm Applied to 250mm expansion joint gaps	435	7,00
COR_300 FS	Aplicado a juntas de dilatação de 300mm Applied to 300mm expansion joint gaps	510	7,00
COR_350 FS	Aplicado a juntas de dilatação de 350mm Applied to 350mm expansion joint gaps	585	7,00
COR_400 FS	Aplicado a juntas de dilatação de 400mm Applied to 400mm expansion joint gaps	650	7,00

Enchimento de juntas multi-revestido Multi coated fire stopping gap filler



» ENCHIMENTO DE JUNTAS COM MÚLTIPLAS PARAGENS DE INCÊNDIO / MULTI COATED FIRE STOPPING GAP FILLER

- ✓ Produzido em baldes de 5 litros e 15 litros / Produced in buckets of 5 liter and 15 liter
- ✓ Densidade 1,35 kg / dm³ / Density 1,35 kg/dm³
- ✓ Temperatura ideal de armazenamento: 5.30C, o prazo de validade mínimo é de 1 ano / Ideal storage temperature: 5.30C, minimum shelf life is 1 year
- ✓ Temperatura de aplicação: 5.30C / Application temperature: 5.30C
- ✓ Tempo de secagem: 2-4 horas / Drying time: 2-4 hours
- ✓ Espessura recomendada: Espessura de chapa úmida 2mm / Recommended thickness: Wet sheet thickness 2mm, Dry sheet
- ✓ Espessura: 1mm / thickness: 1mm
- ✓ Uso: 1,4 lt / m² / Usage: 1,4 lt/m²
- ✓ Cor: branca / Color: white
- ✓ À prova d'água. (Limitado a 25% da capacidade de movimentação) / Waterproof. (Limited to 25% movement capacity)
- ✓ Nota: A lã de rocha precisa ser comprimida 33% antes de encaixar no espaço da junta de expansão / Note: Rockwool needs to be compressed 33% before fitting in to expansion joint gap

Este produto é um agente de enchimento acrílico à base de água, com múltiplas camadas de revestimento contra fogo. Aplicado em lã de rocha por rolo ou spray, interna ou externamente. O preenchimento de juntas corta-fogo tem 25% de capacidade de movimento da junta aplicada e pode resistir ao disparo por até 2 horas.

This product is multi coated water based acrylic fire stopping gap filler. Applied on rock wool by a roll or spray internally or externally. Fire stopping gap filler has 25% movement capacity of gap applied in and can resist to fire up to 2 hours.

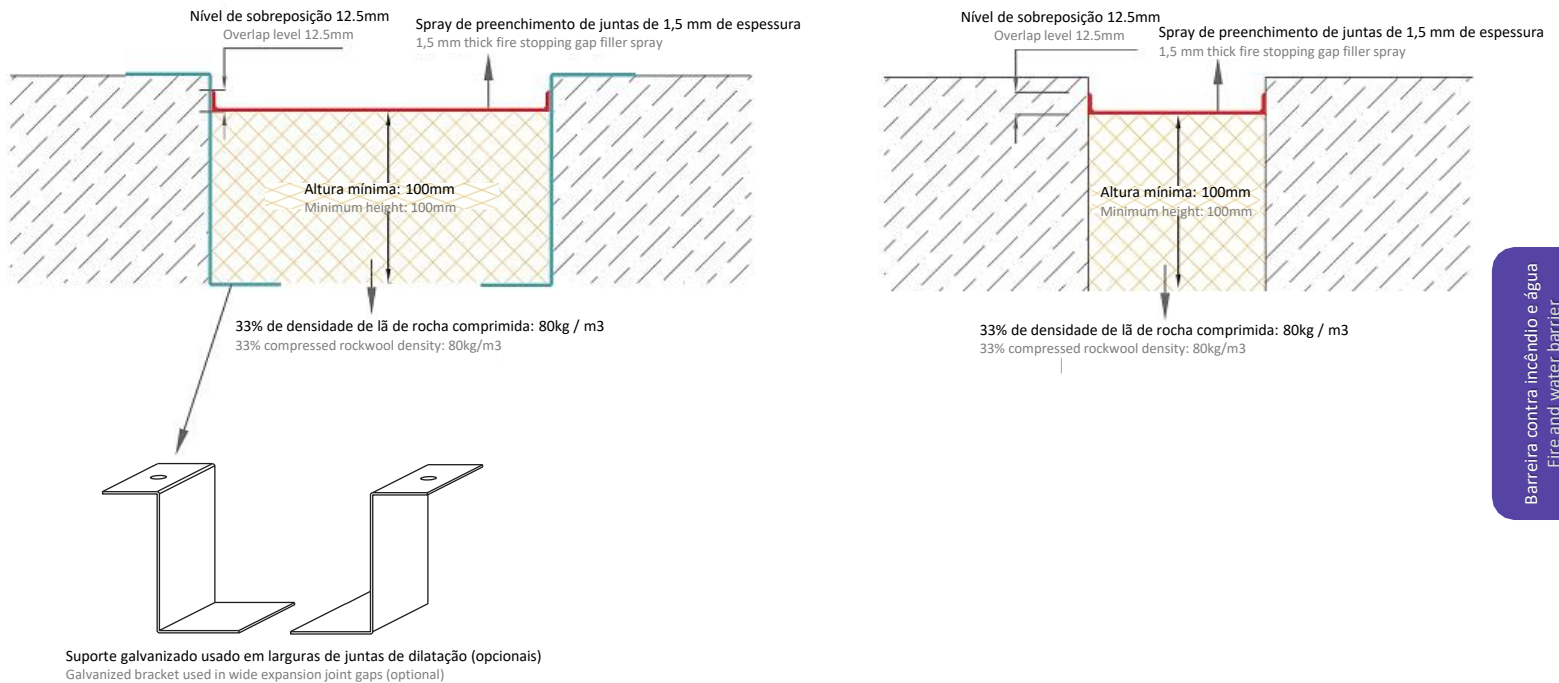

Barreira contra incêndio e água
Fire and water barrier

» TABELA DE USO (Calculado na hipótese de 3mm de espessura para atingir 1,5mm) USAGE TABLE (calculating on the assumption of 3 mm thickness to actually achieve 1.5mm)

LARGURA DO ESPAÇO (mm) GAP WIDTH	LARGURA TOTAL COM NÍVEL DE SOBREPOSIÇÃO ADICIONAL DE 12,5MM (mm) TOTAL WIDTH WITH ADDITIONAL 12,5MM OVERLAP LEVEL	DISTÂNCIA DA LACUNA COBERTA USANDO 1 BALDE DE PRODUTO COM VÁRIOS REVESTIMENTOS (medidor) GAP DISTANCE COVERED BY USING 1 BUCKET OF MULTI COATED PRODUCT (meter)
25	50	110
50	75	75
75	100	55
100	125	45
150	175	35
200	225	30

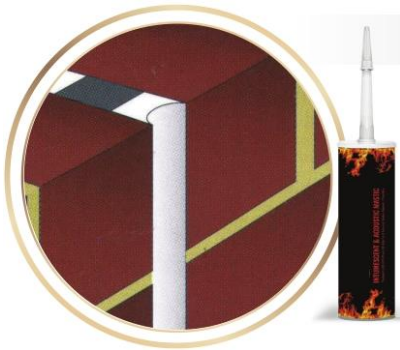

» SELANTE INTUMESCENTE / INTUMESCENT GAP SEALANT

O selante acrílico, flexível e de fácil aplicação (expandido com calor) é usado em intervalos de junta máximos de 35 mm. Não endurece na temperatura externa.

Expande 4 vezes maior que o tamanho original quando submetido ao calor, evita a permeabilidade ao fogo. Evita fumaça e gases nocivos por 4 horas.

Arylic, flexible, easily applicable sealant (expanded with heat) is used in maximum 35mm joint gaps.

Doesn't harden in outdoor temperature. Expands 4 times larger than original size when subjected to heat, prevents fire permeability. Prevents smoke and harmful gases for 4 hours.

- ✓ Selante acrílico flexível, à base de água, inchaço/ Flexible, water based, swelling, acrylic sealant
- ✓ Adequado para os padrões da BS476 Parte 20/22, BS / EN 1363-1 e BS / EN 1366-1
Suitable to standards of BS476 Part 20/22, BS/EN 1363-1 & BS/EN 1366-1
- ✓ Resistente ao fogo por 4 horas / Resistant to fire for 4 hours
- ✓ Flexibilidade a longo prazo / Long-term flexible
- ✓ Excelente aderência / Excellent sticking
- ✓ A largura máxima do espaço é de 35 mm / Maximum gap width is 35mm

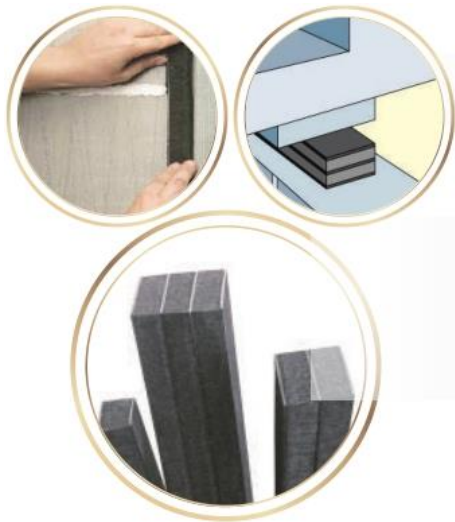
» EPONJA ELASTOMÉRICA / ELASTOMERIC GAP SPONGE

As esponjas elastoméricas de preenchimento de juntas são expandidas com o calor e utilizadas para tornar as lacunas das juntas de dilatação resistentes ao fogo.

Gap filling elastomeric sponges are expand with heat and utilized to make expansion joint gaps fire resistant.

- ✓ Resistente ao fogo até 2 horas / Fire resistant up to 2 hours
- ✓ Não incha pela água / Doesn't swell by water
- ✓ Resistente ao rasgo pelas fortes características de inchaço
Resistant to tearing by the strong swelling characteristics
- ✓ Adequado para diferentes tamanhos de juntas de dilatação
Suitable to different sizes of expansion joint gaps
- ✓ Adequado para betão poroso, betão, vigas metálicas e aplicações em paredes
Suitable for porous concrete, concrete, metal beams and wall applications
- ✓ Adequado para BS476 Part20: 1987 / Suitable to BS476 Part20:1987

» CORDÃO CORTA-FOGO DE LÃ DE ROCHA / ROCKWOOL FIRE ROPE

O cabo Rire é um material de isolamento de espuma e pode ser aplicado facilmente usando fios de vidro em lã de rocha. É colocado em folgas nas juntas de dilatação, comprimindo pelo menos 33%. Deve ser usado com spray de paragem de incêndio para evitar fumaça.

Fire rope is a foam insulation material and can be applied easily by using glass yarn on rock wool . It is placed in expansion joint gaps by compressing at least 33%. It should be used with fire stop joint spray to prevent smoke.

- ✓ Alto desempenho com proteção superior contra incêndio
High performance with superior fire protection
- ✓ Recurso de isolamento térmico / Thermal insulation feature
- ✓ Pode ser aplicado facilmente com sua propriedade não inflamável
It can be applied easily with its non-flammable property
- ✓ O recurso de isolamento acústico está disponível / Sound insulation feature is available
- ✓ Possui baixo coeficiente de condutividade térmica
It has low thermal conductivity coefficient
- ✓ Consistência biológica / Biological consistency
- ✓ Tem uma consistência volumétrica / It has a volumetric consistency
- ✓ É um produto quimicamente neutralizado / It is chemically neutralized product
- ✓ Excelente desempenho devido às suas propriedades repelentes à água
Excellent performance due to its water repellent properties
- ✓ É um produto com alta flexibilidade / It is a product with high flexibility





**HYDRO
FLEX**

**PRODUTOS DE
ISOLAMENTO DE ÁGUA**
Water isolation products





A fita de junta de dilatação HIDROFlex altamente elástica é usada para todos os tipos de edifícios no isolamento de lacunas na junta de dilatação, lacunas térmicas e rachaduras. Opções alternativas estão disponíveis sem orifícios ou com orifícios de 150 mm, 200 mm, 250 mm, 300 mm, 400 mm de largura e 1 mm, 1,5 mm de espessura.
Highly elastic HIDROFlex expansion joint tape is used for every type of buildings in isolating expansion joint gaps, thermal gaps and cracks. Alternative options are available for without holes or with holes at 150mm, 200mm, 250mm, 300mm, 400mm width and 1mm, 1,5mm thickness.

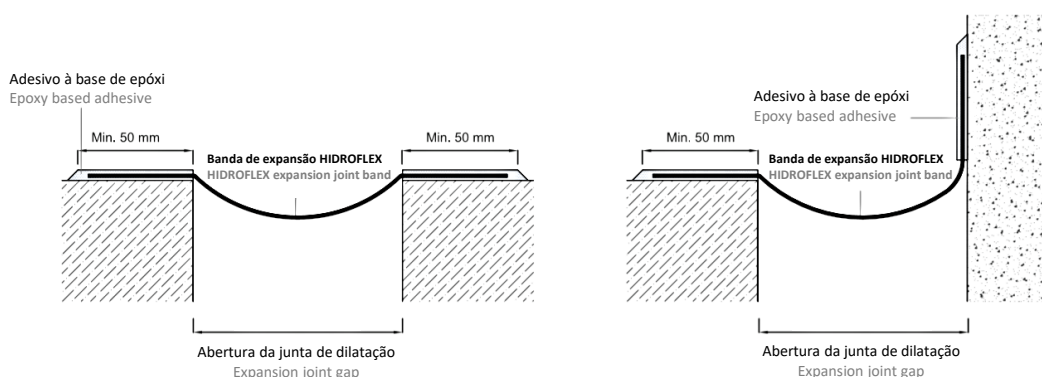

ESPECIFICAÇÕES E VANTAGENS / SPECIFICATIONS AND ADVANTAGES

- Fácil aplicação com adesivo epóxi. / Easy application with epoxy adhesive.
- Característica altamente elástica (600%) / Highly elastic characteristic (600%)
- Forte adesão ao betão, aço e muitos outros materiais de construção.
Strong adhesion to concrete, steel and many other building materials.
- Resistente às raízes das plantas / Resistant to plant roots
- Resistentes a UV e óleo. / UV and oil resistant.
- Bom desempenho entre amplos valores de temperatura.
Good performance between wide temperature values.
- Fácil de cortar, soldar (ar quente) e unir. / Easy to cut, weld (hot air) and joint.

ÁREAS DE USO DO HIDROFLEX / HIDROFLEX USAGE AREAS

- Aplicação horizontal e vertical em todos os tipos de edifícios
Horizontal and vertical application on all type of buildings
- Fundações e paredes cortinas / Foundations and curtain walls
- Estações de tratamento de águas residuais, estações de tratamento de água potável, tanques de água
Wastewater treatment plants, potable water plants, water tanks pools
- Túneis, tubos e caixas de betão / Tunnels and concrete pipes and boxes
- Entre as linhas de conexão da fundação e da parede de cortina.
Between foundation and curtain wall connection lines.

ESPECIFICAÇÕES TÉCNICAS HIDROFLEX HIDROFLEX TECHNICAL SPECIFICATIONS

Composição química Chemical composition	TPE (Elastómero termoplástico) / (thermoplastic elastomer)
Cor Color	Cizento / Grey
Nível de dureza Hardness level	80
Valor da temperatura de serviço Serving temperature value	-40°C / +90°C
Valor da temperatura térmica Thermal temperature value	270°C
Alongamento na ruptura Elongation at break	600%
Resistência ao rasgo Tear strength	>600N/cm
Valor resistente à pressão da água Water pressure resistant value	>8 Barra/Bar
Resistência à tração Tensile strength	>6 Mpa
Resistência UV UV resistance	>7500 h
Resistência ao betume Bitumen resistance	Boa / Good
Resistência ao ácido sulfúrico Sulfuric acid resistance	Boa / Good
Resistência ao álcool Alcohol resistance	Boa / Good
Resistência detergente Detergent resistance	Boa / Good

Barreira contra incêndio e água
Fire and water barrier

REF	LARGURA WIDTH	ESPESSURA THICKNESS	COMPRIMENTO LENGTH
HIDROFLEX 150	150	1 mm & 1.5mm	25mt Rolo/ Roll
HIDROFLEX 200	200	1 mm & 1.5mm	25mt Rolo/ Roll
HIDROFLEX 250	250	1 mm & 1.5mm	25mt Rolo/ Roll
HIDROFLEX 300	300	1 mm & 1.5mm	25mt Rolo/ Roll
HIDROFLEX 400	400	1 mm & 1.5mm	25mt Rolo/ Roll

» 1º Passo / 1st step



» 2º Passo / 2nd step



» 3º Passo / 3rd step



» 4º Passo / 4th step



» ÁREA DE APLICAÇÃO / APPLICATION AREA

Colagem de juntas de dilatação com fita que ancora as hastes e barras ao betão, pedra ou tijolo. Reparação e isolamento de grandes rachaduras.
 Bonding of expansion joints tape anchoring the rods and bars to the concrete, stone or brick. Repair and isolation of wide cracks.

» ESPECIFICAÇÕES E VANTAGENS / SPECIFICATION AND ADVANTAGES

Adesão perfeita ao betão e aço, resistente a produtos químicos, livre de solventes. Pode ser aplicada em todos os tipos de fendas de juntas de dilatação, impermeáveis a água e gás, adesão perfeita às superfícies úmidas do betão, fácil de aplicar, não precisa de primer antes inscrição.

HIDROFLEX 21 é uma composição de 2 materiais à base de epóxi. Utilizado para fins de fixação, ancoragem e colagem.

Perfect adhesion to the concrete and steel resistant to chemicals solvent free, It can be applied all types of expansion joint gap, water and gas impermeable, perfect adhesion to the damp surfaces on concrete, easy to apply, it doesn't need any primer before application.

HIDROFLEX 21 is a composition of 2 epoxy-based material. Used for fixing, anchoring and sticking purposes.

 ESPECIFICAÇÕES TÉCNICAS DO ADESIVO DE DILATAÇÃO À BASE DE EPÓXI
 TECHNICAL SPECIFICATIONS OF EPOXY BASED DILATATION ADHESIVE

Número de componentes Number of components	2 componentes A e B / 2 components A and B
Especificações químicas Chemical specifications	Componente A – Resina epóxi / A component – epoxy resin Componente B – Endurecedor epóxi / B component – epoxy hardener
Taxa mista - peso A / B Mixed rate - weight A/B	3,75kg / 1,25kg
Densidade mista Mixed density	1,7kg / lt
Totalmente curado Fully cured	Uso de pedestres 24 horas, serviço totalmente curado e aberto - 7 dias Pedestrian usage 24 hours fully cured and open service - 7days
Duração do pote Pot life	40 dk (20C)
Tempo de cura Curing time	Recuperável após 8-10 horas totalmente curado - 7 dias Recoupable after 8-10 hours fully cured - 7 days



» FITA DE CÂMARA E RACHADURA / CHAMBER AND CRACK TAPE

O HIDROFLEX 120 é usado para isolar pontos críticos em cantos de áreas úmidas e isolar áreas necessárias. O HIDROFLEX 120 é adequado para muitos materiais.

HIDROFLEX 120 is used for isolation of critical point on wet area corners and isolation required areas. HIDROFLEX 120 is suitable with many of materials.

- ✓ Não precisa de uso de adesivo extra, pois é compatível com qualquer tipo de material de isolamento
It doesn't need any extra adhesive usage as it is compatible with any kind of isolation materials
- ✓ Fácil aplicação / Easy application
- ✓ Alta capacidade de elasticidade / High elasticity capacity
- ✓ 100% à prova de água / 100% waterproof
- ✓ Resistente a muitos tipos ou produtos químicos / Resistant to many kind or chemicals
- ✓ Bom resistente ao ozônio e UV / Good resistant to Ozone and UV
- ✓ Alto desempenho para ampla faixa de temperatura (-40, + 90°C)
High performance for wide temperature range (-40, +90°C)

Nota: Nossa nova banda de versões de feltro também está disponível no código do produto HYDROFLEX 121.
Note: Our new felt version band is also available under HYDROFLEX 121 product code.



» BANDA DE ABSORÇÃO DE ÁGUA À BASE DE BETONILHA DE SÓDIO / SODIUM BETONITE BASED WATER SWELLING BAND

Faixa de dilatação da água projetada para preencher juntas ou rachaduras no betão ao dilatar em contato com a água.

Water swelling band designed to fill gaps or crack in concrete by swelling in contact with water.

- ✓ Fácil de aplicar / Easy to apply
- ✓ Aplicação fácil, mesmo com grande quantidade de vergalhões
Easy application even with huge amount of rebar
- ✓ Colocar na posição correta e pressionar são só estas as etapas para a montagem nas áreas de conexão
Placing in right position and pressing are only the steps for mounting to connection areas
- ✓ O recurso de absorção com segurança não permite que ele fique inchado em caixas de betão vazadas
Safely swelling feature does not allow it to get swollen in pouring concrete cases
- ✓ Pode ser usado em piscinas, túneis, metros, muros de arrimo, paredes de cortina
Can be used in swimming pools, tunnels, subways, retaining walls, curtain walls
- ✓ Pode ser usado em tanques de água, sistemas de esgoto e instalações de purificação de água
Can be used in water tanks, sewage systems and water purification facilities
- ✓ Juntas de betão, barragens, estradas e cruzamentos de betão antigos e novos.
Concrete joints, dams, road and intersections of old and new concretes.



» BANDA DE ABSORÇÃO DE ÁGUA À BASE DE ACRÍLICO / ACRYLIC BASED WATER SWELLING BAND

A banda de absorção de água à base de acrílico fica incha quando em contato com a água.

As áreas de aplicação são: piscinas, tanques de água, estações de esgoto e juntas de construção. Também aplicável em juntas frias, onde as cortinas são conectadas com fundações e áreas de contato de perfis de aço e tubos com betão. Pode ser usado para fornecer forças também em áreas expostas à água do mar.

Acrylic based water stop band gets swollen when in contact with water.

Application areas are swimming pools, water tanks, sewage plants and construction joints. Also applicable in cold joints where curtains are connected with foundations and steel profile and pipe's contact areas with concrete. It can be used to provide seals in areas exposed to sea water as well.

- ✓ Fácil de aplicar / Easy to apply
- ✓ Pode ser usado em várias superfícies / Can be used in various surfaces
- ✓ Aplicação fácil, mesmo com grande quantidade de vergalhões.
Easy application even with huge amount of rebar
- ✓ O recurso de absorção com segurança não permite que ele fique inchado em caixas de betão vazadas
Safely swelling feature does not allow it to get swollen in pouring concrete cases
- ✓ Preenche possíveis lacunas e rachaduras por inchaço e atua como uma barreira à água na estrutura de betão armado
Fills possible gaps and cracks by swelling and acts as a water barrier in the reinforced concrete structure
- ✓ Resistente ao teor de água altamente salgada e a vários produtos químicos
Resistant to highly salted water content and various chemicals

Vialonga - Portugal
geral@cortartec.net
(+351) 219824133

Espanha - Madrid
+34 917 374 005
espana@cortartec.net

França - Lyon
+33 975 181 167
france@cortartec.net

Perú - Lima
+51 164 192 22
peru@cortartec.net

Brasil - Rio de Janeiro
+55 2140420115
brasil@cortartec.net

Venezuela - Caracas
+58 212 720 2555
venezuela@cortartec.net

Argélia - Algiers
+213 983 200 261
algerie@cortartec.net

CE