

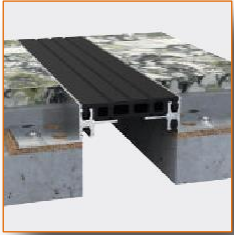

- Juntas para pavimento
- Juntas sísmicas
- Juntas para paredes y techos
- bandas de fuego
- juntas de movimiento
- juntas industriales
- Juntas estanques
- Juntas de cobertura
- Juntas de estacionamiento

Catálogo general de juntas de expansión
General catalogue of expansion joints





JUNTAS DE SUELO, PARED, JUNTAS DE TECHO

Junta de expansión económica - adecuada para cargas de peatones y vehículos ligeros

GASKETED FLOOR, WALL, CEILING PROFILES

Economic expansion joint profiles-suitable for pedestrian load and light vehicle loads.

PAGE
07-25



JUNTAS DE SUELO, PAREDES Y REVESTIMIENTOS

Las juntas de expansión de acero o muelle atornillado en un lado se utilizan en aplicaciones para paredes o techos de cemento crudo.

FLOOR, WALL, CEILING COVER PROFILES

One sided screwed or steel spring expansion joint profiles are used in applications for gross concrete walls or ceilings.

PAGE
26-29



JUNTAS DE PAVIMENTO, SERIE300 PARED Y TECHO

La composición de juntas de aluminio y juntas de expansión insertadas en TPE son adecuadas para centros comerciales, estructuras industriales ligeras, almacenes, hospitales, aeropuertos y estaciones de metro. Adecuado para lugares donde la carga del vehículo es de carga peatonal ligera a media e intensa.

300 SERIES FLOOR, WALL AND CEILING PROFILES

Composition of aluminium profiles and TPE inserted expansion joint profiles are suitable for shopping centres, light industrial structures, warehouses, hospitals, airports and metro stations. Suitable to places where subjected light to medium vehicle load and intense pedestrian load.

PAGE
30-37



ARTICULACIONES HIGIÉNICAS JUNTAS DE EXPANSIÓN DE SERVICIO PESADO

Las juntas de expansión COR 700 - COR 800 y las juntas de suelo sinusal son de servicio pesado. Se aplican perfectamente en centros comerciales, hospitales, naves industriales y etc. con sus estructuras higiénicas y decorativas.

HEAVY DUTY HYGIENIC EXPANSION JOINT PROFILES

COR 700 and 800 series of expansion joint profiles and sinus type floor profiles are resistant to heavy loads. They are perfectly performed at shopping malls, hospitals, industrial buildings and etc. with their hygienic and decorative structures.

PAGE
38-49

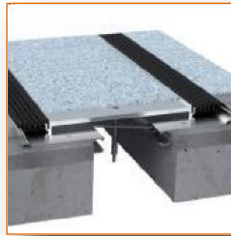

JUNTAS SÍSMICAS SUELO, PARED Y TECHO

Las juntas de expansión sísmica tienen alta capacidad de movimiento y se pueden aplicar fácilmente a grandes distancias. Adecuado para muchos tipos de pisos.

SEISMIC FLOOR, WALL AND CEILING PROFILES

Seismic expansion joint profiles have high movement capacity and can easily be applied to large gaps. Suitable for many types of floor coverings.

 PAGE
50-69

UNIONES DE EXPANSIÓN Aparcamiento

La composición de las juntas de expansión de caucho, acero y aluminio es amortiguador (silencioso) e ideal para proyectos de estacionamiento.

CARPARK EXPANSION JOINT PROFILES

Composition of rubber, steel and aluminium car park expansion joint profiles are sound dampen (silent) and ideal for carpark projects

 PAGE
70-77

JUNTAS COMPLETAS JUNTAS DE EXPANSIÓN ESTANCAS

Estas juntas de expansión se utilizan en zonas húmedas, terrazas y aparcamientos abiertos donde están sometidos al agua. Se utilizan fácilmente con materiales de aislamiento.

COMPLETE WATERTIGHT EXPANSION JOINT PROFILES

These expansion joint profiles are used in wet areas, terraces and open car parks where subjected to water. They are easily used with isolation materials.

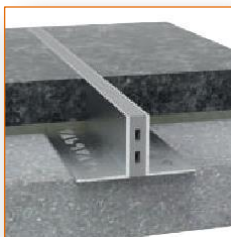
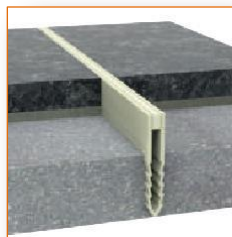
 PAGE
78-95

JUNTAS DE MOVIMIENTO

Las juntas de movimiento están diseñadas para evitar grietas en pisos de cerámica o granito debido a la dilatación por el clima caluroso. Se pueden utilizar para zonas interiores y exteriores.

MOVEMENT JOINT PROFILES

Movement joint profiles are designed to avoid cracks in ceramic or granite floors because of expansion due to hot weather. They can be used for both internal and external areas.

 PAGE
96-101

JUNTA PARA LAJE CONTROL DE CONTRACCIÓN Y DILATACIÓN

El producto de la junta de chapa de acero ayuda a resolver la junta dentro de 7 a 14 días por sí mismo. Se utiliza como alternativa a cualquier corte manual adicional en aplicaciones de hormigón de losa.

SHRINKAGE AND CRACK CONTROL SLAB JOINT

Steel slab joint product helps to settle the joint within 7 to 14 days by itself only. It is used as alternative to any extra manual cuttings on slab concrete applications.

 PAGE
102-105

BARRERAS CONTRA INCENDIOS Y AGUA

Diferentes tipos de barreras hidroflecciones y contra incendios diseñadas para detener el agua y el fuego en las áreas de las juntas de expansión.

FIRE AND WATER BARRIERS

Different type of hydroflex and fire barriers designed to stop the water and fire in expansion joint profile areas.

 PAGE
106-114

Juntas de expansión de suelos incrustados
Flush mounted floor expansion joint profiles



COLORES DE NUDILLOS
/ GASKET COLOURS

 **NEGRO**
BLACK
 **GRIS**
GREY
 **CREMA**
CREAM

» COR030_100

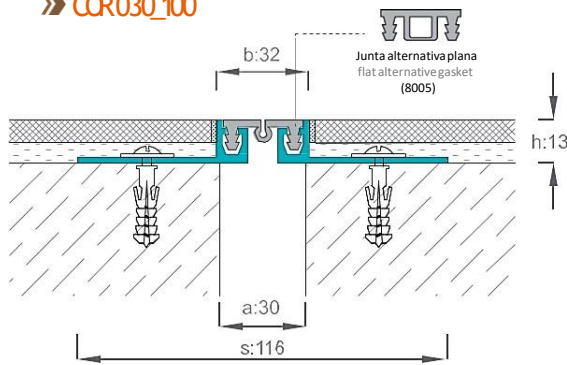

» COR030K_00

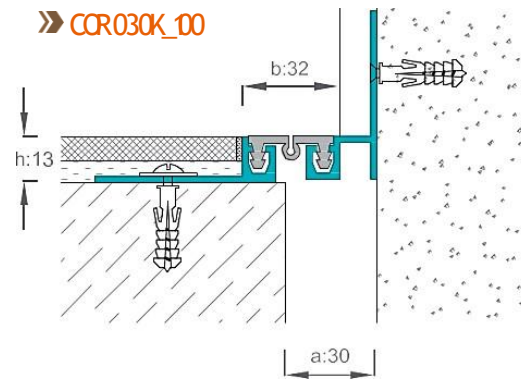

» COR030_102

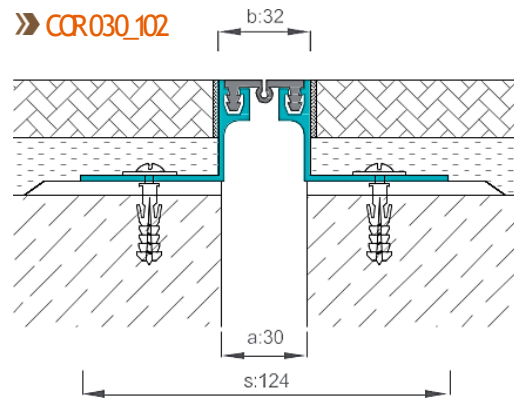

» COR030_120

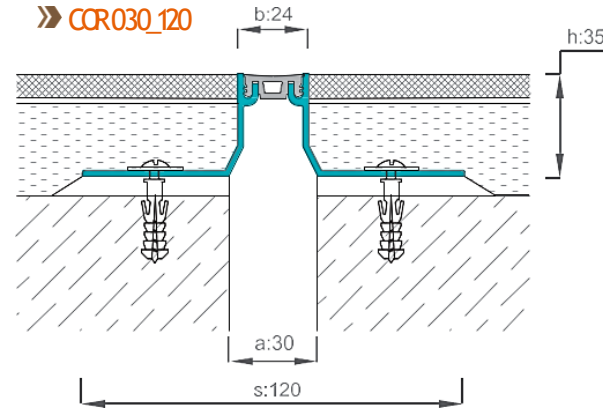







Tipo de junta de pared y
techo
gasket type: floor, wall,
Ceiling profiles

Con sellado intermedio bajo la dilatación del piso final, las juntas son adecuadas para intervalos de 30 mm. Se pueden utilizar en diferentes niveles de suelo, como cerámica, granito, mosaico y solado. Generalmente aplicado en áreas de carga peatonal y carga de vehículos ligeros (no intensas) (h: 26mm y superior). Montado en el suelo en ambos lados, con un espaciado de 35 cm con anclajes y tornillos adecuados. La alternativa de sellado suave debe utilizarse en áreas higiénicas.

Middle gasketed under finish floor expansion, joint profiles are suitable for 30mm gaps. Can be used in different levels of floor coverings such as ceramic, granite, mosaic and screed. Usually applied to pedestrian load and light vehicle load (not intense) areas (h:26mm and above). Mounted to floor from both sides by having 35cm spacing with appropriate anchors and screws. Smooth gasket alternative should be used in hygienic areas.



REF	DESCRIPCIÓN DESCRIPTION	ANCHO CONJUNTO (a) mm JOINT WIDTH	SUPERFICIE VISIBLE (b) mm SURFACE VISIBLE	ALTURA (h) mm PROFILE HEIGHT	ANCHO (s) mm TOTAL WIDTH	SUPERFICIE SURFACE	CAPACIDAD DE MOVIMIENTO MOVEMENT CAPACITY	CAPACIDAD DE CARGA LOAD CAPACITY
COR_030 100	Utilizado en cerámica, adecuado 8-10mm Used in ceramic, suitable 8-10mm	30	32	13	116	Acabamento Alu + TPE Mill finish ALU + TPE	±10	
COR_031 100	Utilizado en cerámica, adecuado 12-14mm Used in ceramic, suitable 8-10mm	30	32	20	100	Acabamento Alu + TPE Mill finish ALU + TPE	±10	
COR_030 101	Adecuado para granito natural, mármol, etc. Suitable for natural granite, marble, etc.	30	32	26	116	Acabamento Alu + TPE Mill finish ALU + TPE	±10	
COR_030 102	Adecuado para granito, mármol, etc. Suitable for granite, marble, etc.	30	32	35	124	Acabamento Alu + TPE Mill finish ALU + TPE	±10	
COR_030 103	Adecuado para suelos industriales, granito, etc. Suitable for industrial floors, granite, etc.	30	32	50	124	Acabamento Alu + TPE Mill finish ALU + TPE	±10	
COR_030 120	Adecuado para cerámica, mármol, etc. Suitable for ceramic, marble, etc.	30	32	35	120	Acabamento Alu + TPE Mill finish ALU + TPE	±5	

Juntas de expansión de suelos incrustados
 Flush mounted floor expansion joint profiles

COLORES DE NUDILLOS
/ GASKET COLOURS

 **NEGRO**
 BLACK

 **GRIS**
 GREY

 **CREMA**
 CREAM

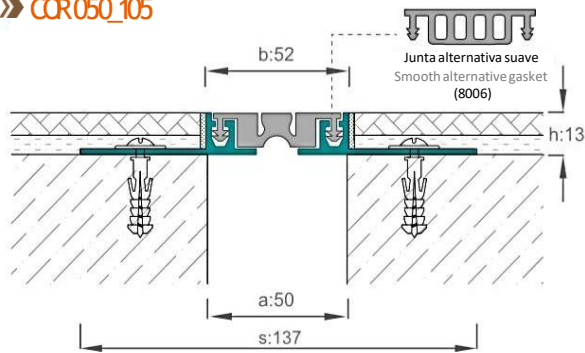
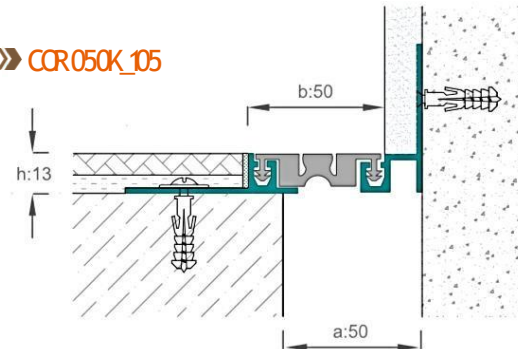
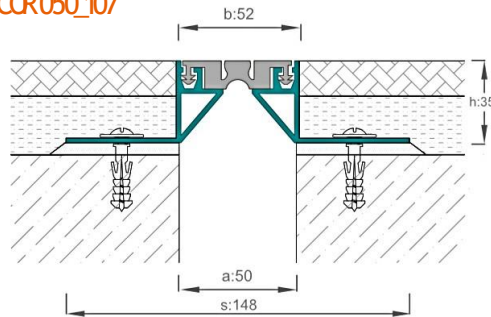
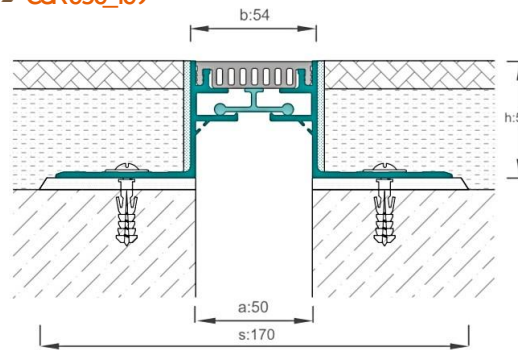









»» COR050_105

»» COR050K_105

»» COR050_107

»» COR050_109

Tipo de junta de pared y
 techo
 gasket type: floor, wall,
 Ceiling profiles

Las juntas de expansión del suelo son adecuadas para espacios libres de 50 mm. Se puede utilizar en todos los revestimientos a diferentes alturas. La alternativa de unión suave también está disponible. Montado en el suelo en ambos lados, con un espaciado de 35 cm con anclajes y tornillos apropiados.

Gasketed under finish floor expansion joint profiles are suitable for 50mm gaps. Can be used in all floor covers at different heights. Smooth gasket alternative is also available. Mounted to floor from both sides by having 35cm spacing with appropriate anchors and screws.



REF	DESCRIPCIÓN DESCRIPTION	ANCHO CONJUNTO (a) mm JOINT WIDTH	SUPERFICIE VISIBLE (b) mm SURFACE VISIBLE	ALTURA (h) mm PROFILE HEIGHT	ANCHO (s) mm TOTAL WIDTH	SUPERFICIE SURFACE	CAPACIDAD DE MOVIMIENTO MOVEMENT CAPACITY	CAPACIDADE CARGA LOAD CAPACITY
COR_050_105	Adecuado para cerámica de 8-10 mm Suitable for 8-10mm ceramic	50	52	13	137	Acabamento Alu + TPE Mill finish ALU + TPE	± 10	
COR_050_106	Adecuado para granito natural, mármol, etc.. Suitable for natural granite, marble etc.	50	52	26	136	Acabamento Alu + TPE Mill finish ALU + TPE	± 10	2,5 Ton 
COR_050_107	Adecuado para granito natural, mármol, solado, etc.. Suitable for Natural granite, marble and etc.	50	52	35	148	Acabamento Alu + TPE Mill finish ALU + TPE	± 10	2,5 Ton  2 Ton 
COR_051_107	Adecuado para granito, mármol y etc (económico). Suitable for granite, marble and etc (economic).	50	52	35	134	Acabamento Alu + TPE Mill finish ALU + TPE	± 10	
COR_052_107	Adecuado para revestimientos de suelo de PVC. Suitable with PVC floor coverings	50	60	35	146	Acabamento Alu + TPE Mill finish ALU + TPE	± 10	2,5 Ton  2 Ton 
COR_053_107	Adecuado para granito natural, mármol, solado, etc.. Suitable for Natural granite, marble and etc.	50	52	50	148	Acabamento Alu + TPE Mill finish ALU + TPE	± 10	2,5 Ton 
COR_054_107	Adecuado para granito natural, mármol, solado, etc.. Suitable for Natural granite, marble and etc.	50	52	50	149	Acabamento Alu + TPE Mill finish ALU + TPE	± 10	2,5 Ton  2 Ton 
COR_050_109	Adecuado para granito natural, mármol, solado (superficie plana). Suitable for Natural granite, marble, solado (Flat surface)	50	54	50	170	Acabamento Alu + TPE Mill finish ALU + TPE	± 10	

Juntas de dilatación de pavimento de embutir
Flush mounted floor expansion joint profiles



COLORES DE NUDILLOS / GASKET COLOURS:

- NEGRO**
BLACK
- GRIS**
GREY
- CREMA**
CREAM

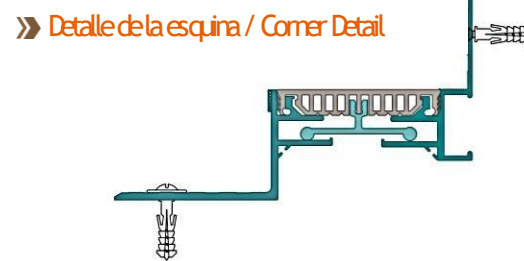
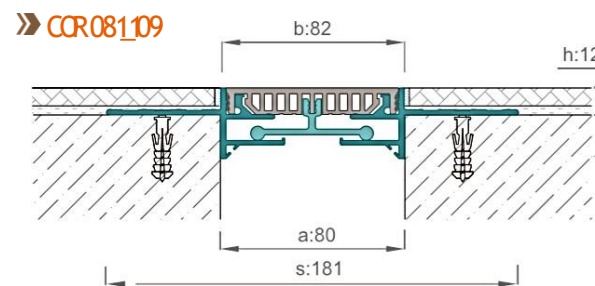
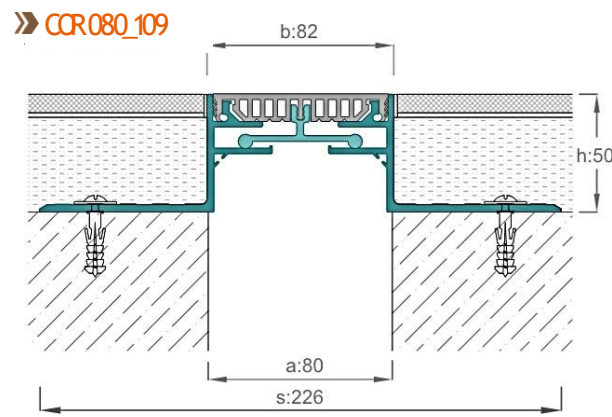
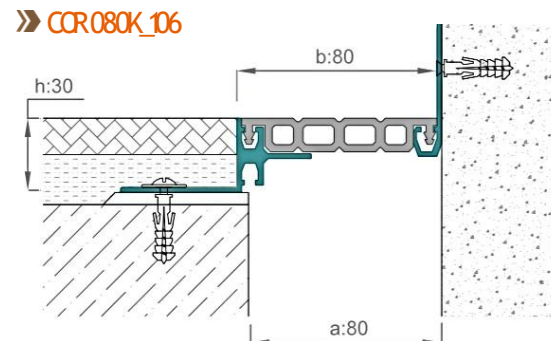
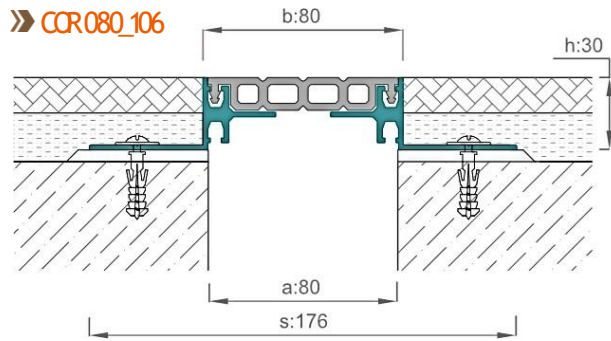

Tipo de junta de pared y
techo
gasket type: floor, wall,
ceiling profiles

Juntas de expansión con un acabado adecuado para intervalos de 80 mm. Se utiliza en zonas donde está sujeta a la carga peatonal.
Under finish expansion joint profiles suitable for 80mm gaps. Utilized in areas where subjected to pedestrian load.

REF	DESCRIPCIÓN DESCRIPTION	ANCHO CONJUNTO (a) mm JOINT WIDTH	SUPERFICIE VISIBLE (b) mm SURFACE VISIBLE	ALTURA (h) mm PROFILE HEIGHT	ANCHO (s) mm TOTAL WIDTH	SUPERFICIE SURFACE	CAPACIDAD DE MOVIMIENTO MOVEMENT CAPACITY	CAPACIDAD DE CARGA LOAD CAPACITY
COR_080_106	Adecuado para superficie superior plana, granito, mármol, etc... Suitable for flat top surface, granite, marble etc.	80	80	30	176	Acabamento Alu + TPE Mill finish ALU + TPE	± 10	
COR_080_109	Adecuado para revestimientos decorativos higiénicos Suitable for decorative/hygienic coverings.	80	82	50	226	Acabamento Alu + TPE Mill finish ALU + TPE	± 10	
COR_081_109	Adecuado para revestimientos de 8 a 10 mm. Suitable for 8 to 10mm coverings.	80	82	12	181	Acabamento Alu + TPE Mill finish ALU + TPE	± 10	
COR_100_106	Adecuado para cerámica, mármol, etc... Suitable for ceramic, marble, etc.	100	100	30	200	Acabamento Alu + TPE Mill finish ALU + TPE	± 15	
COR_100_734	Adecuado para aparcamientos abiertos y cerrados, asfalto, etc... Suitable for open/closed car parks, asphalt etc.	100	150	50	240	Acabamento Alu + TPE Mill finish ALU + TPE	± 50	30 Ton

Juntas de expansión de suelos incrustados
Flush mounted floor expansion joint profiles



COLORES DE NUDILLOS
/ GASKET COLOURS



» COR 100_106

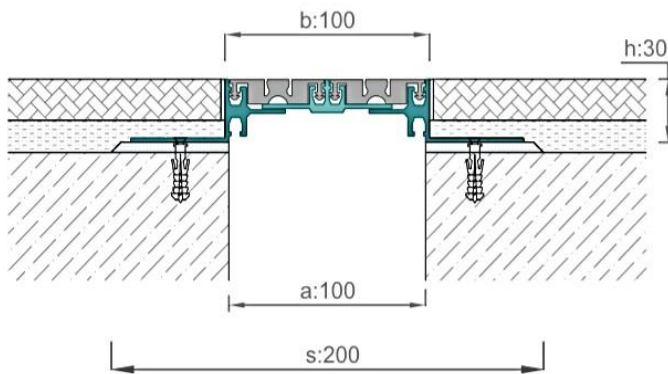

» COR 100K_106

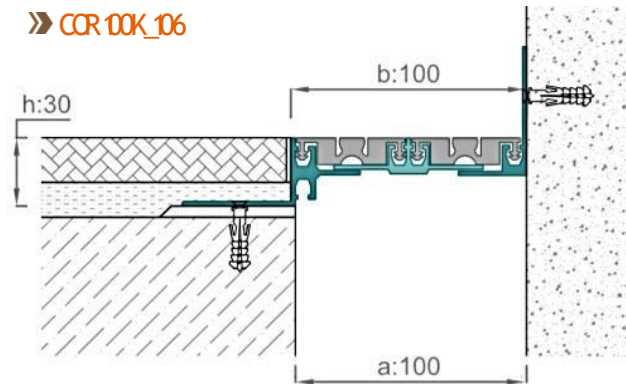

Tipo de junta de pared y
techo
gasket type: floor, wall,
Ceiling profiles

» COR 100_734

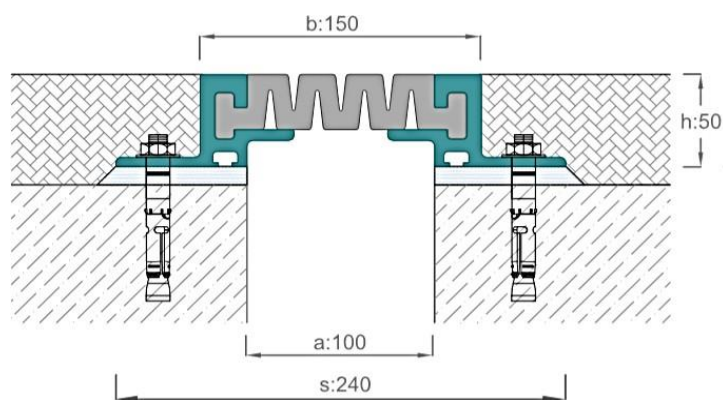

» COR 100K_734

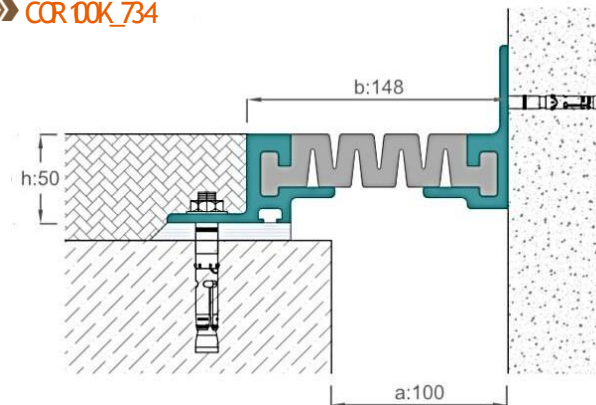

Las juntas de expansión de acabado especial se utilizan normalmente para un espacio libre de 100 mm. Utilizable para diferentes niveles en revestimientos cerámicos, de granito, mosaicos y de suelo. El COR 100_734 es adecuado para la carga de vehículos. También se puede utilizar en aplicaciones de estacionamiento.

Under finish expansion joint profiles with special gasket are used for 100mm gap. Usable for different levels in ceramic, granite, mosaic and screed type floor covers. COR 100_734 is suitable for vehicle load. Can also be used in carpark applications.



Juntas de expansión de suelo superpuestas
Surface mounted floor expansion joint profiles



COLORES DE NUDILLOS
/ GASKET COLOURS:



»» COR030_152

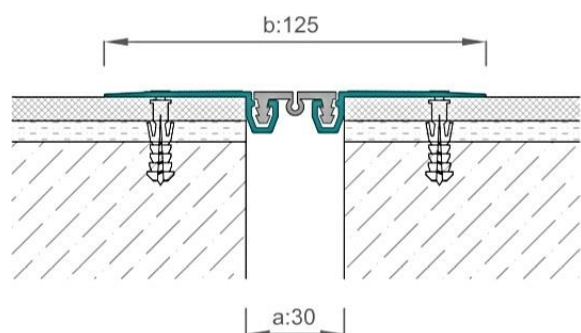

»» COR030K_152

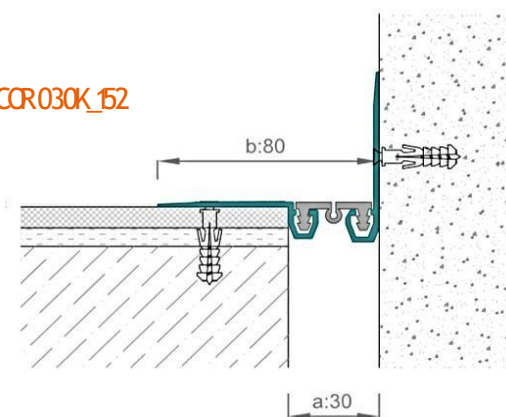

»» COR030_150

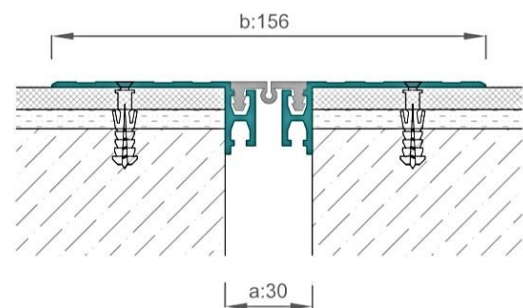

»» COR030_154

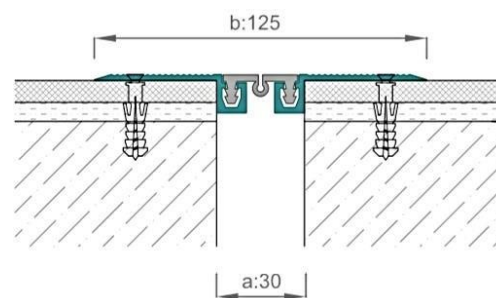

Tipo de junta de pared y
techo
gasket type: floor, wall,
Ceiling profiles

Las juntas de expansión de acabado se utilizan para distancias de 30 mm. Montado a ambos lados del suelo con intervalos de 35cm. Generalmente, adecuado para peatones y carga de vehículos ligeros.
Over finish expansion joint profiles with special gasket are used for 30mm gap. Mounted to the both sides of the floor with intervals of 35cm. Generally, Suitable for pedestrians and light vehicle load.



REF	DESCRIPCIÓN DESCRIPTION	ANCHO CONJUNTO (a) mm JOINT WIDTH	SUPERFICIE VISIBLE (b) mm SURFACE VISIBLE	ALTURA (h) mm PROFILE HEIGHT	LARGURA (s) mm TOTAL WIDTH	SUPERFICIE SURFACE	CAPACIDAD DE MOVIMIENTO MOVEMENT CAPACITY	CAPACIDAD DE CARGA LOAD CAPACITY
COR_030_150	Agujeros de tornillo anchos, decorativos y anchos. Anodised screw holes, decorative and wide	30	156	24	156	Aluminio anod. + TPE Aluminium anod. + TPE	± 10	Leve light
COR_030_152	Agujeros de tornillo anódos, decorativos y estrechos. Anodised screw holes, decorative and narrow	30	125	12	125	Aluminio anod. + TPE Aluminium anod. + TPE	± 10	
COR_030_154	Junta de dilatación no anodizada. Not anodised floor profile	30	125	12	125	Acabamento Alu + TPE Mill finish ALU + TPE	± 10	

Juntas de expansión de suelo superpuestas
Surface mounted floor expansion joint profiles



COLORES DE NUDILLOS:
/ GASKET COLOURS



» COR050_153

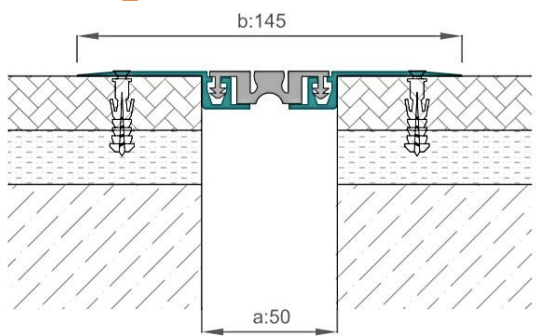

» COR050K_153

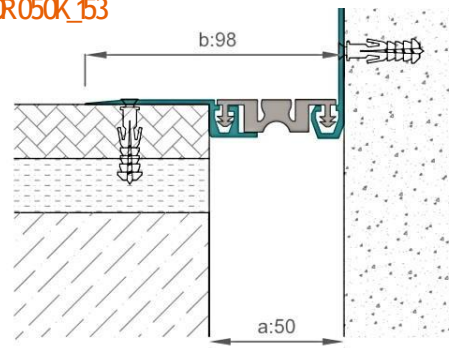

» COR050_51

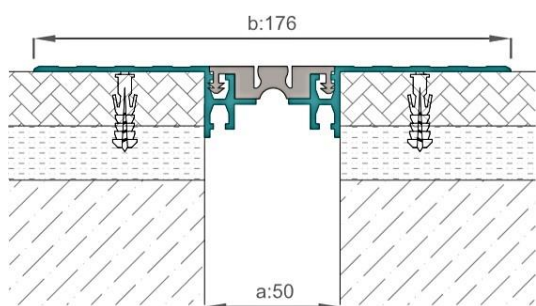

» COR050_154

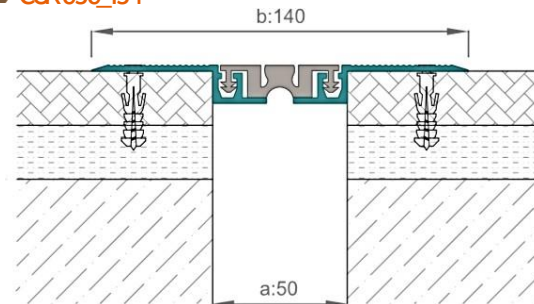

Tipo de junta de pared y
techo
gasket type: floor, wall,
ceiling profiles

Las juntas de expansión de acabado se utilizan para distancias de 50 mm. Generalmente, es adecuado para peatones y carga de vehículos ligeros.

Over finish expansion joint profiles with special gaskets are used for 50mm gap. Generally, suitable for pedestrians and light vehicle load.

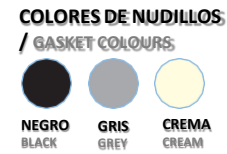

REF	DESCRIPCIÓN DESCRIPTION	ANCHO CONJUNTO (a) mm JOINT WIDTH	SUPERFICIE VISIBLE (b) mm SURFACE VISIBLE	ALTURA (h) mm PROFILE HEIGHT	ANCHO (s) mm TOTAL WIDTH	SUPERFICIE SURFACE	CAPACIDAD DE MOVIMIENTO MOVEMENT CAPACITY	CAPACIDAD DE CARGA LOAD CAPACITY
COR_050_151	Superficie anodizada y ancha. Anodised and wide top surface.	50	176	24	176	Aluminio anod. + TPE Aluminium anod. + TPE	± 10	Leve light
COR_051_151	Zona de todo el año (económica) Anodised and wide top surface (economy)	50	176	12	176	Aluminio anod. + TPE Aluminium anod. + TPE	± 10	
COR_050_153	Anodizado, decorativo y aburrido. Anodised, decorative and crested.	50	145	12	145	Aluminio anod. + TPE Aluminium anod. + TPE	± 10	
COR_050_154	Granito sin anodizar. Not anodised floor profile.	50	140	12	140	Acabamento Alu + TPE Mill finish ALU + TPE	± 15	

Juntas de expansión de suelo superpuestas
 Surface mounted floor expansion joint profiles

» COR080_153

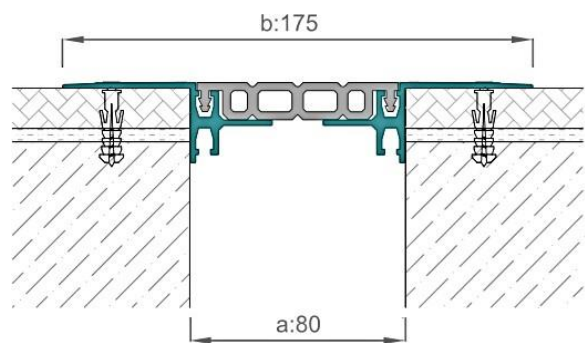

» COR100_153

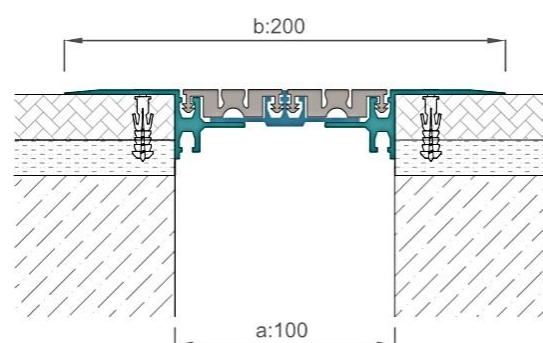

» COR100_191

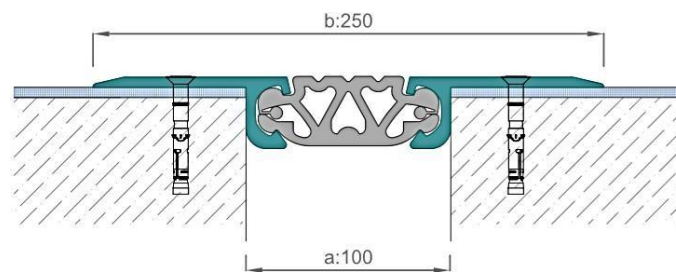

Tipo de junta de pared y
techo
gasket type: floor, wall,
Ceiling profiles

Las juntas de expansión de acabado final se utilizan para distancias de 80 o 100 mm. COR 080_153 y COR 100_153 son los más adecuados para aplicaciones en suelos de cerámica, granito y mármol. El COR 100_191 se utiliza para aplicaciones de estacionamiento de mesa y se monta en el suelo en ambos lados con la ayuda de un anclaje adecuado.

Over finish expansion joint profiles with special gasket are used for 80mm or 100mm gap. COR 080_153 and COR 100_153 is more suitable on applications for ceramic, granite and marble floor covers. COR 100_191 is used for Car park applications for screed mounted to the floor by both sides with a help of appropriate anchor.



REF	DESCRIPCIÓN DESCRIPTION	ANCHO CONJUNTO (a) mm JOINT WIDTH	SUPERFICIE VISIBLE (b) mm SURFACE VISIBLE	ALTURA (h) mm PROFILE HEIGHT	ANCHO (s) mm TOTAL WIDTH	SUPERFICIE SURFACE	CAPACIDAD DE MOVIMIENTO MOVEMENT CAPACITY	CAPACIDAD DE CARGA LOAD CAPACITY
COR_080_153	Sobre acabado, anodizado y furado por parafuso. Over finish, anodised and screw hole d.	80	175	28	175	Aluminio anod. + TPE. Aluminium anod. + TPE.	± 10	
COR_100_153	Sobre acabado, anodizado y furado por parafuso. Over finish, anodised and screw hole d.	100	200	28	200	Aluminio anod. + TPE. Aluminium anod. + TPE.	± 15	
COR_100_191	Especial para parques de estacionamiento. Special for car parks floor.	100	250	30	250	Acabamento Alu + borracha. Mill finish ALU + rubber	± 15	30 Ton



¿Por qué se creó la dilatación?
Why dilatation has been created?

SÉRIE COR 191/106/153/107 COR SERIES 191 / 106 / 153 / 107

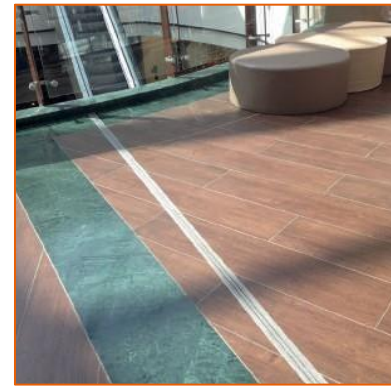
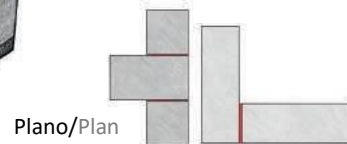
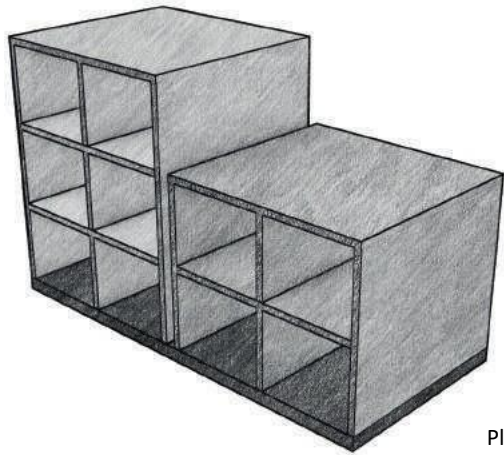

Estructuras expuestas a expansiones térmicas horizontal y verticalmente- estructuras asimétricas
Structures exposed to thermal expansions horizontally and vertically unsymmetrical structures

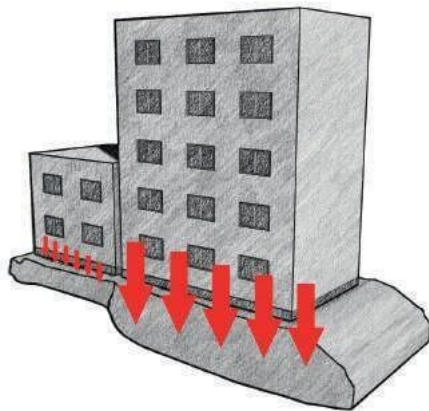

Estructuras bajo diferentes tipos de suelo y cargas
Structures under different floor types and loads

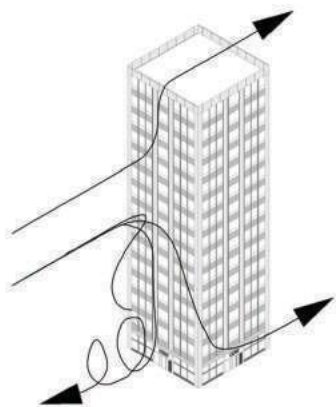

Estructuras expuestas a cargas de viento
Structures exposed to wind loads

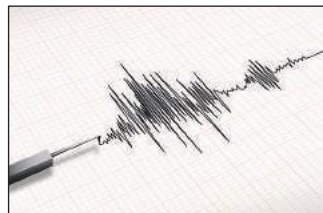

Movimientos sísmicos
Earthquake Movements

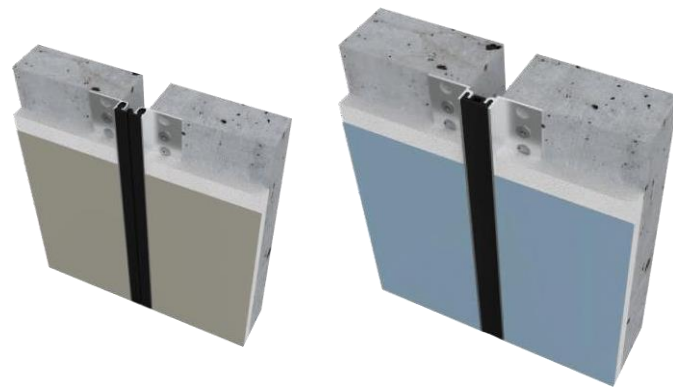

Juntas de incrustación de pared y techo
 Flush mounted wall and ceiling profiles

 COLORES DE NUDILLOS
 / GASKET COLOURS

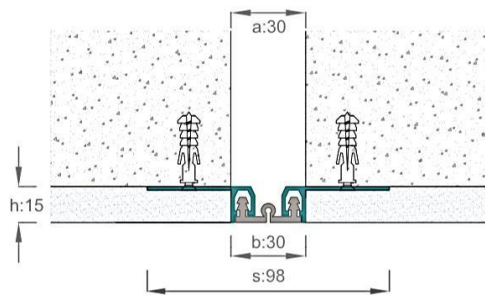

» COR030_200

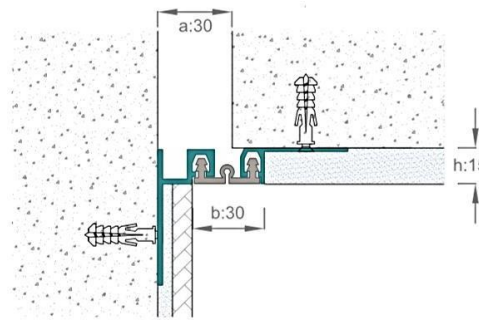

» COR030K_200

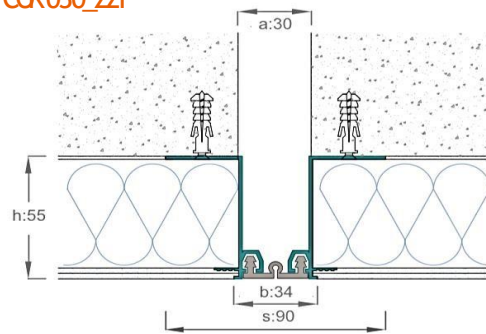

» COR030_221



» COR031_220

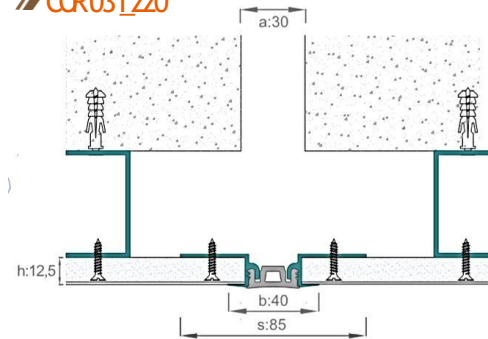

 Tipo de junta de pared y
 techo
 gasket type: floor, wall,
 Ceiling profiles

Las juntas de expansión de pared de 30 mm son adecuadas para pequeñas distancias y movimientos térmicos. Las juntas de expansión se pueden quitar y cambiar fácilmente. Estas juntas son más compatibles con las juntas de suelo. Adecuado para paneles de aislamiento térmico, yeso, cerámica y cerámica con inserto de 30mm.

30 mm wall expansion joint profiles are suitable for small gaps and thermal movements. Gaskets on the expansion joint profiles can be removed and changed easily. These profiles are more compatible with floor profiles. Suitable to plaster, dry wall, ceramic and thermal insulation boards with 30mm insert.

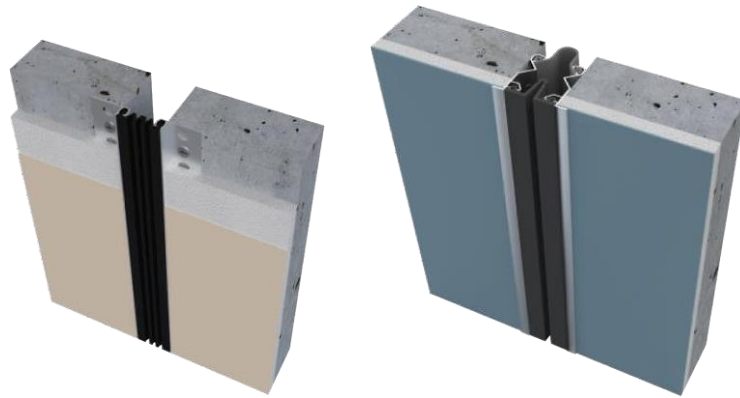

REF	DESCRIPCIÓN DESCRIPTION	ANCHO CONJUNTO (a) mm JOINT WIDTH	SUPERFICIE VISIBLE (b) mm SURFACE VISIBLE	ALTURA (h) mm PROFILE HEIGHT	ANCHO (s) mm TOTAL WIDTH	SUPERFICIE SURFACE	CAPACIDAD DE MOVIMIENTO CAPACITY MOVEMENT
COR_030_200	Adecuado para yeso de 12 mm. Cerámica, yeso. Suitable for 12mm plaster, ceramic, drywall	30	30	15	98	Acabamento Alu. + TPE Mill finish ALU + TPE	± 10
COR_031_200	Adecuado para yeso de 14-18mm. Cerámica, yeso. Suitable for 14-18mm plaster, ceramic, drywall	30	30	20	100	Acabamento Alu. + TPE Mill finish ALU + TPE	± 10
COR_030_220	Yeso sellado, placas de yeso, etc.. Narrowed gasketed plaster, drywall etc.	30	24	12,5	90	Acabamento Alu. + TPE Mill finish ALU + TPE	± 5
COR_031_220	Adecuado para techos suspendidos y perfiles de ánodos para paredes. Suitable to suspended ceiling and profiles for drywall etc.	30	40	12,5	85	Aluminio anod. + TPE Aluminium anod. + TPE	± 5
COR_030_220	Adecuado para materiales de fachada y aislamiento térmico. Suitable to facade and thermal insulation materials	30	34	50+5	90	Acabamento Alu. + TPE Mill finish ALU + TPE	± 10



» COR_050_202

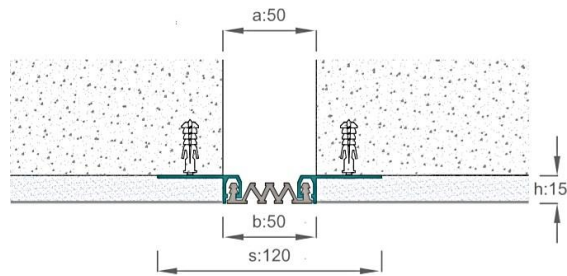

» COR_050K_202

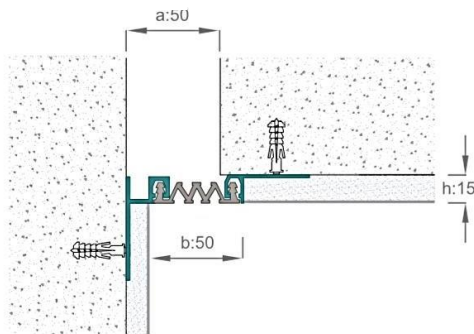

Tipo de junta de pared y
techo
gasket type: floor, wall,
Ceiling profiles

» COR_050_221

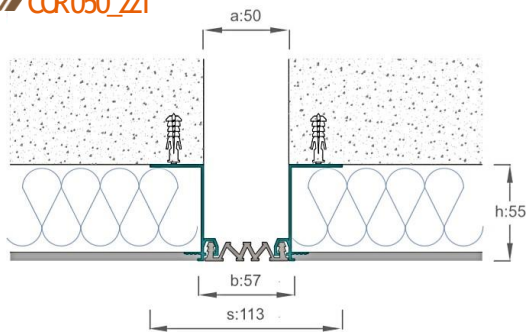

» COR_050_285

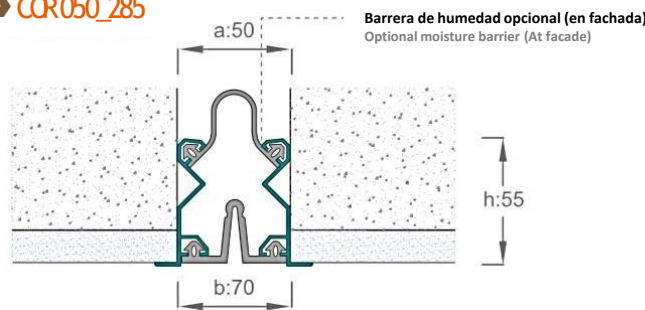

Estas juntas de expansión son adecuadas para distancias de 50 mm y se utilizan en placas de aislamiento térmico de yeso, cerámica y fs apropiados.
These expansion joint profiles suitable for 50mm gap and used on appropriate plaster, ceramic, drywall ad thermal isolation boards.



REF	DESCRIPCIÓN DESCRIPTION	ANCHO CONJUNTO (a) mm JOINT WIDTH	SUPERFICIE VISIBLE (b) mm SURFACE VISIBLE	ALTURA (h) mm PROFILE HEIGHT	ANCHO (s) mm TOTAL WIDTH	SUPERFICIE SURFACE	CAPACIDAD DE MOVIMIENTO CAPACITY MOVEMENT
COR_050_202	Adequado para cerámica, yeso, cartonado etc. / sellado de pared. Suitable for ceramic, drywall etc. / wall gasketed.	50	50	15	120	Acabamento Alu + TPE Mill finish ALU + TPE	± 20
COR_051_202	Adequado para cerámica, gesso cartonado, etc. / Vedação de pavimento Suitable for ceramic, drywall etc. / Floor gasketed	50	50	15	120	Acabamento Alu + TPE Mill finish ALU + TPE	± 10
COR_050_203	Adequado para betonilha 14-18mm a cerâmica. Suitable for 14-18mm screed and ceramic.	50	50	20	120	Acabamento Alu + TPE Mill finish ALU + TPE	± 20
COR_050_221	Adequado para aislamientos térmicos e fachadas etc. Suitable for thermal insulation and facade etc.	50	57	50+5	113	Acabamento Alu + TPE Mill finish ALU + TPE	± 20
COR_050_285	Sísmica adecuada para áreas internas e de fachada. Suitable seismic for internal and facade areas.	50	70	55	70	Acabamento Alu + TPE Mill finish ALU + TPE	± 25

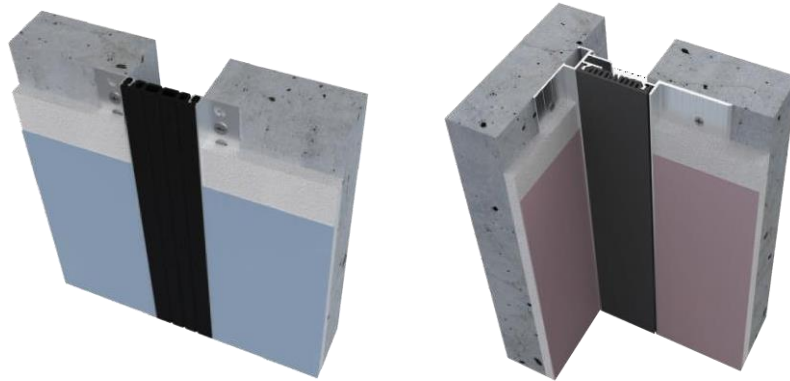

»» COR080_202

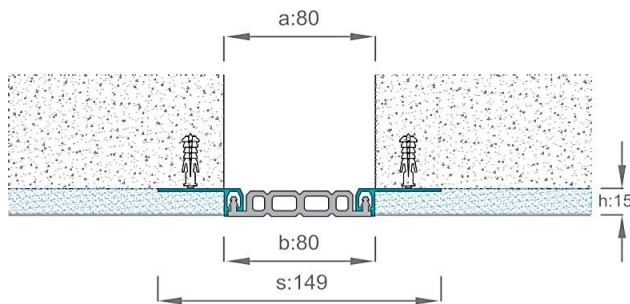

»» COR080_202

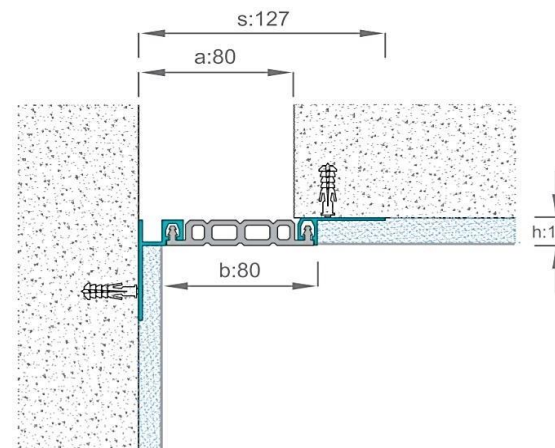

Tipo de junta de pared y
techo
gasket type: floor, wall,
ceiling profiles

»» COR080_215

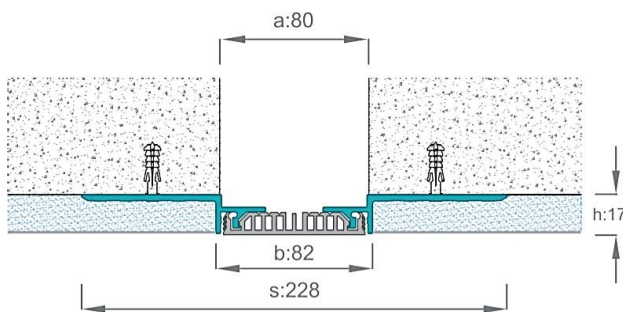

»» COR080K_215

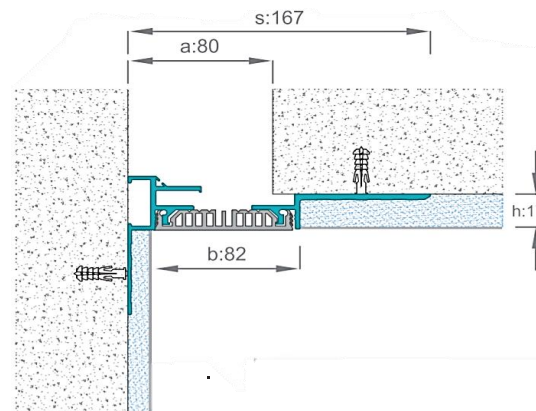

Adecuado para cubiertas de suelo de nivel similar con juntas intermedias elastoméricas.
Juntas de expansión con acabado final utilizadas para intervalos de 80mm. Recomendado para estructuras sujetas a pequeños movimientos.
Suitable to similar level flooring covers with elastomeric middle gaskets. Under finish expansion joint profiles used for 80mm gaps. Recommended for structures where subject to small movements.

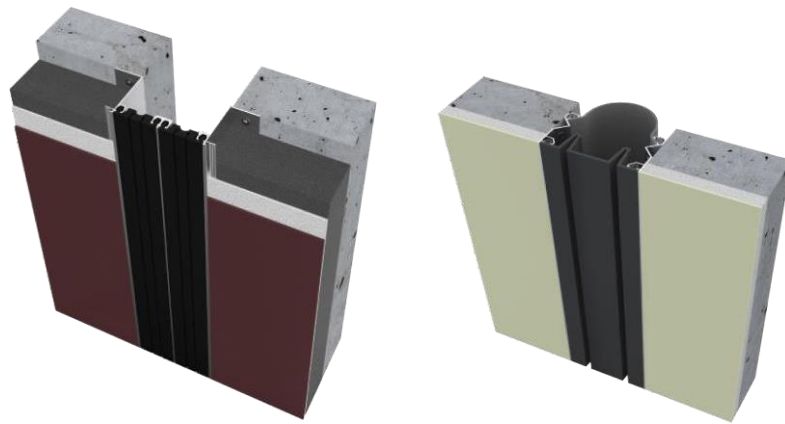

REF	DESCRIPCIÓN DESCRIPTION	ANCHO CONJUNTO (a) mm JOINT WIDTH	SUPERFICIE VISIBLE (b) mm SURFACE VISIBLE	ALTURA PERFIL (h) mm PROFILE HEIGHT	ANCHO TOTAL (s) mm TOTAL WIDTH	SUPERFICIE SURFACE	CAPACIDAD DE MOVIMIENTO MOVEMENT CAPACITY
COR_080 202	Adecuado con solado (COR_80 106), cerámica, etc., con detalles planos de la junta. Suitable with (COR_80 106) screed/ceramic and etc. with flat gasket detail.	80	80	15	149	Acabamento Alu + TPE Mill finish ALU + TPE	± 10
COR_080 215	Adecuado con solado (COR_80 109), cerámica, etc., con detalles planos de la junta. Suitable with (COR_80 109) screed/ceramic and etc. with flat gasket detail.	80	82	17	228	Acabamento Alu + TPE Mill finish ALU + TPE	± 10

Juntas de incrustación de pared y techo
 Flush mounted wall and ceiling profiles

COLORES DE NUDILLOS
/ GASKET COLOURS

NEGRO
BLACK
 GRIS
GREY
 CREMA
CREAM

» COR 100_202

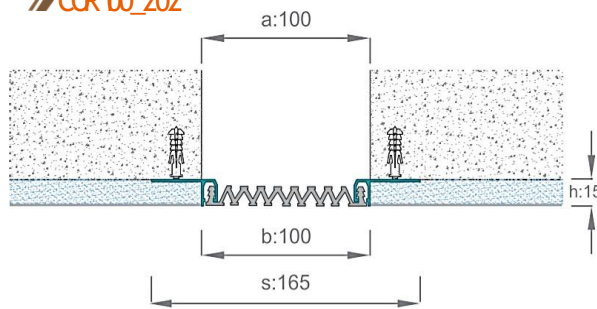

» COR 102_202

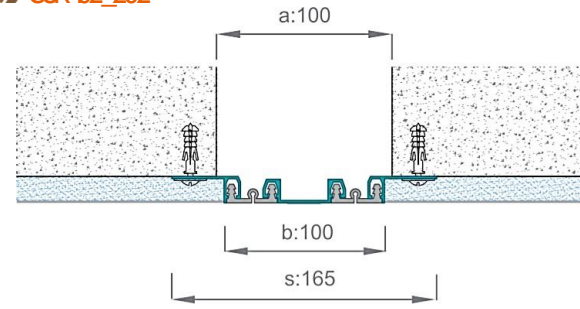

» COR 101_221

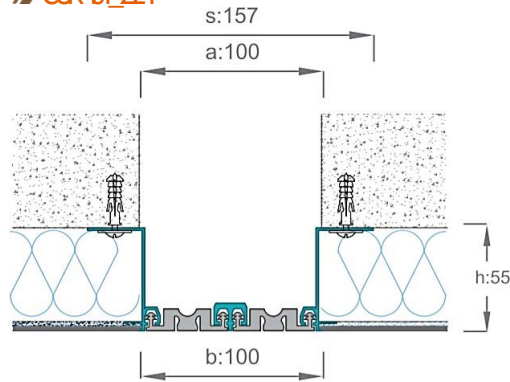

» COR 100_285

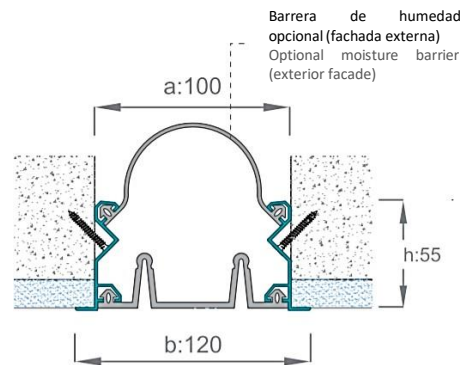
 Tipo de junta de pared y
techo
gasket type: floor, wall,
ceiling profiles

Juntas de expansión adecuadas para distancias de 100 mm con selecciones de juntas alternativas. Se utiliza en tablas apropiadas de yeso, cerámica, sujeto de pared seca y aislamiento térmico.
Expansion joints profiles suitable for 100mm gap with alternative gasket selections. Used on appropriate plaster, ceramic, subjected dry wall and thermal isolation boards.

REF	DESCRIPCIÓN DESCRIPTION	ANCHO CONJUNTO (a) mm JOINT WIDTH	SUPERFICIE VISIBLE (b) mm SURFACE VISIBLE	ALTURA PERFIL (h) mm PROFILE HEIGHT	ANCHO TOTAL (s) mm TOTAL WIDTH	SUPERFICIE SURFACE	CAPACIDAD DE MOVIMIENTO MOVEMENT CAPACITY
COR_100_202	Adecuado para solado, cerámica, yeso y etc Suitable for screed, ceramic, dry wall and etc	100	100	15	165	Acabamento Alu + TPE Mill finish ALU + TPE	± 50
COR_101_202	Adecuado para solado, cerámica, placa de yeso, etc. (cercado por suelo) Suitable for screed, ceramic, dry wall and etc. (floor gasketed)	100	100	15	165	Acabamento Alu + TPE Mill finish ALU + TPE	± 16
COR_102_202	Adecuado para solado, cerámica, placas de yeso, etc. (junta decorativa y estrecha) Suitable for screed, ceramic, dry wall and etc. (decorative and narrow gasketed)	100	100	15	165	Alu anodizado + TPE Anodised ALU + TPE	± 14
COR_100_203	Adecuado para solado, cerámica, placas de yeso, etc. (14+18mm) Suitable for screed, ceramic, dry wall and etc. (14+18mm)	100	100	20	165	Acabamento Alu + TPE Mill finish ALU + TPE	± 50
COR_100_221	Adecuado para fachada con su característica externa. Suitable for facade with its external profile feature	100	100	50+5	157	Acabamento Alu + TPE Mill finish ALU + TPE	± 50
COR_101_221	Adecuado para aislamiento térmico de fachadas, etc. (cercado por el suelo) Suitable for heat insulation and facade and etc. (floor gasketed)	100	100	50+5	157	Acabamento Alu + TPE Mill finish ALU + TPE	± 16
COR_102_221	Adecuado para aislamiento térmico de fachadas, etc. (sello plano) Suitable for heat insulation and facade and etc. (flat gasketed)	100	100	50+5	157	Acabamento Alu + TPE Mill finish ALU + TPE	± 16
COR_100_285	Adecuado para zonas interiores y fachada. (sísmica) Suitable with internal bases and facade (seismic)	100	120	55	120	Acabamento Alu + TPE Mill finish ALU + TPE	± 75

Juntas de pared y techo montadas en superficie
Surface mounted wall and ceiling profiles

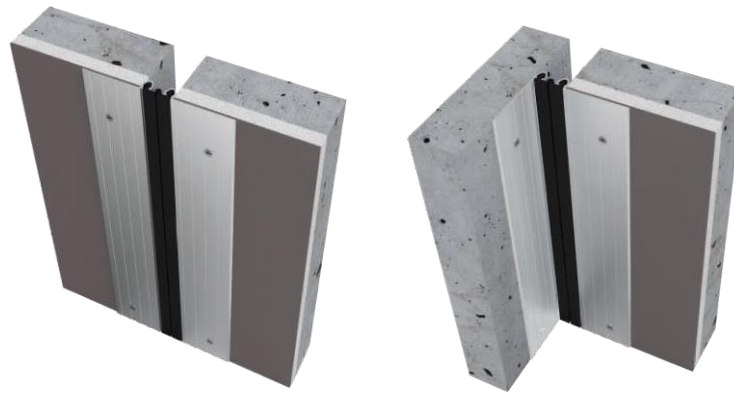

COLORES DE NUDILLOS
/ GASKET COLOURS

 **NEGRO**
BLACK
 **GRIS**
GREY
 **CREMA**
CREAM

» **COR030_251**

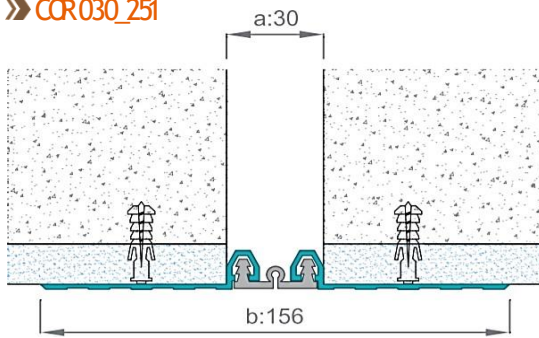

» **COR030_253**

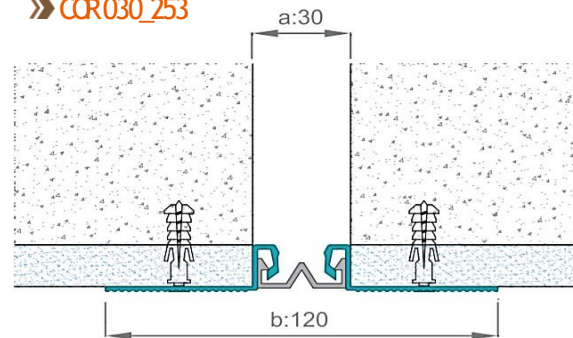

» **COR030_262**

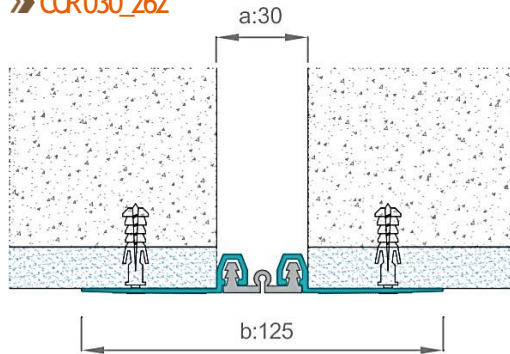

» **COR030K_262**

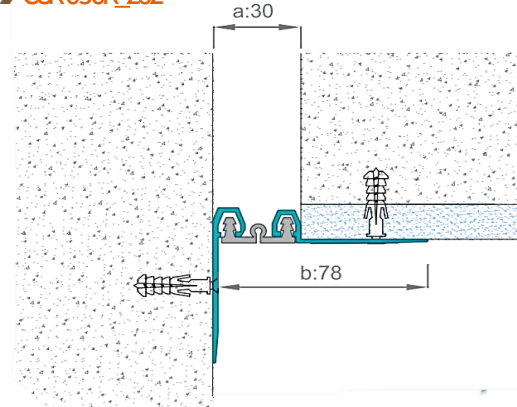

Tipo de junta: pared y techo
 gasket type: floor, wall,
 ceiling

Las juntas de expansión de acabado excesivas son adecuadas para intervalos de 30 mm. Recomendado para estructuras donde se somete a factores térmicos y pequeños movimientos. Cada diseño tiene la opción de junta de esquina. Las juntas se suministran en 25 metros.

Over finish expansion joint profiles are suitable for 30mm gap. Recommended for structures where subjected to thermal factors and small movements. Each design has corner profile option. Profiles are delivered by 3 meters and gaskets 25 meters.



REF	DESCRIPCIÓN DESCRIPTION	ANCHO CONJUNTO (a) mm JOINT WIDTH	SUPERFICIE VISIBLE (b) mm SURFACE VISIBLE	ALTURA PERFIL (h) mm PROFILE HEIGHT	ANCHO TOTAL (s) mm TOTAL WIDTH	SUPERFICIE SURFACE	CAPACIDAD DE MOVIMIENTO MOVEMENT CAPACITY
COR_30_251	Superficie superior ancha anodizada. Anodised wide top surface.	30	156	12	156	Alu anodizado + TPE Anodised ALU + TPE	± 10
COR_30_253	Perfil de pared con acabado laminado. Mill finish wall-ceiling profile.	30	120	14	120	Acabamento Alu + TPE Mill finish ALU + TPE	± 10
COR_030_255	Acabado superficial superior ancho. Mill finish wide top surface.	30	180	14	180	Acabamento Alu + TPE Mill finish ALU + TPE	± 10
COR_030_260	Anodizado, agujeros de tornillo, decorativo. Anodised, screw holes, decorative.	30	125	12	125	Alu anodizado + TPE Anodised ALU + TPE	± 10
COR_030_262	Anodizado, agujeros de perno, decorativo, económico. Anodised, screw holes, decorative, economic.	30	125	12	125	Alu anodizado + TPE Anodised ALU + TPE	± 10

Juntas de pared y techo montadas en superficie
 Surface mounted wall and ceiling profiles

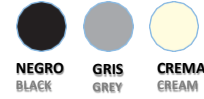
 COLORES DE NUDILLOS
 / GASKET COLOURS

» COR050_252

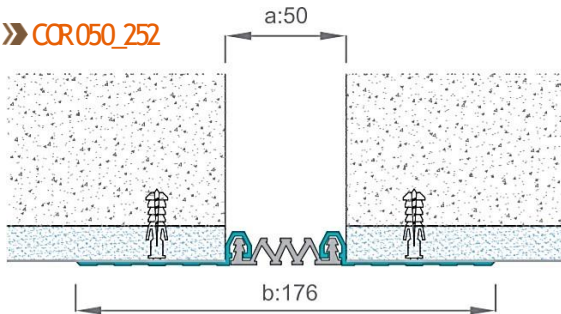

» COR050_254

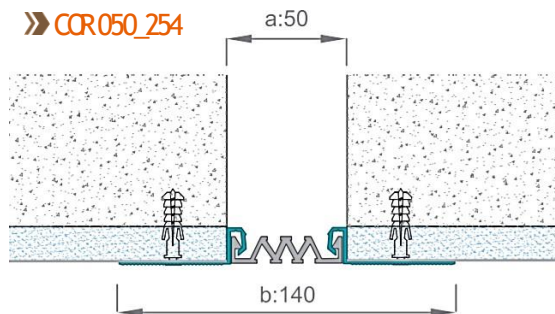

» COR050_262

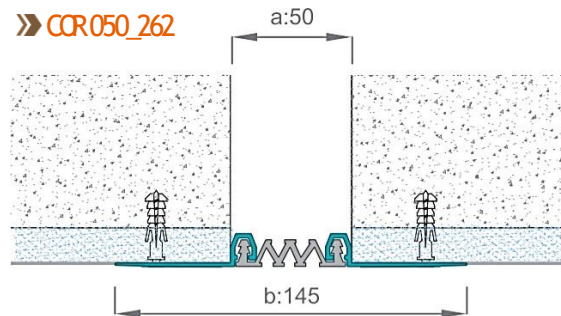

» COR051_262

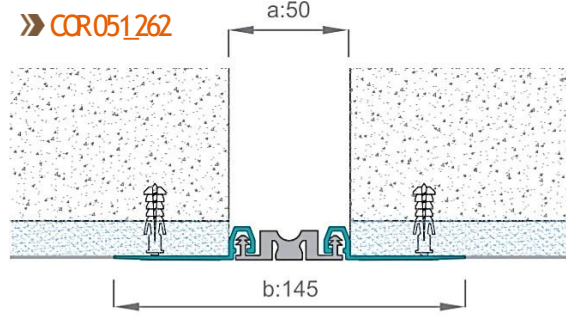
 Tipo de junta de pared y
 techo
 gasket type: floor, wall,
 ceiling profiles

Las juntas de expansión montadas en superficie son adecuadas para distancias de 50 mm. Opciones de juntas: pulido y anodizado están disponibles. Los agujeros se fabrican como parte de la producción. Se puede montar fácilmente y es compatible con juntas de suelo.

Surface mounted expansion joint profiles are suitable for 50mm gap. Mat anodized and polished profile options are available. Screw holes are made as part of the production. Can be easily assembled and compatible to floor profiles.



REF	DESCRIPCIÓN DESCRIPTION	ANCHO CONJUNTO (a) mm JOINT WIDTH	SUPERFICIE VISIBLE (b) mm SURFACE VISIBLE	ALTURA PERFIL (h) mm PROFILE HEIGHT	ANCHO TOTAL (s) mm TOTAL WIDTH	SUPERFICIE SURFACE	CAPACIDAD DE MOVIMIENTO MOVEMENT CAPACITY
COR_050_252	Superficie superior ancha anodizada Anodised wide top surface	50	176	12	176	Alu anodizado + TPE Anodised ALU + TPE	± 20
COR_051_252	Superficie superior de todo el año (cercada por pavimento) Anodised wide top surface (floor gasketed)	50	176	12	176	Alu anodizado + TPE Anodised ALU + TPE	± 10
COR_050_254	Junta de pared con acabado laminado Mill finish wall-ceiling profile	50	140	14	140	Acabamento Alu + TPE Mill finish ALU + TPE	± 20
COR_050_255	Amplia superficie superior del acabado del molino Mill finish wide top surface	50	200	14	200	Acabamento Alu + TPE Mill finish ALU + TPE	± 20
COR_050_261	Anodizado, perforado en tornillo, decorativo Anodised, screw holes, decorative	50	145	12	145	Alu anodizado + TPE Anodised ALU + TPE	± 20
COR_050_262	Anodizado, atornillado, decorativo, económico Anodised, screw holes, decorative, economic	50	145	12	145	Alu anodizado + TPE Anodised ALU + TPE	± 20
COR_051_262	Agujero anodizado, roscado / piso sellado Anodised, screw hole / floor gasketed	50	145	12	145	Alu anodizado + TPE Anodised ALU + TPE	± 10

Juntas de parede e teto montados na superfície
Surface mounted wall and ceiling profiles

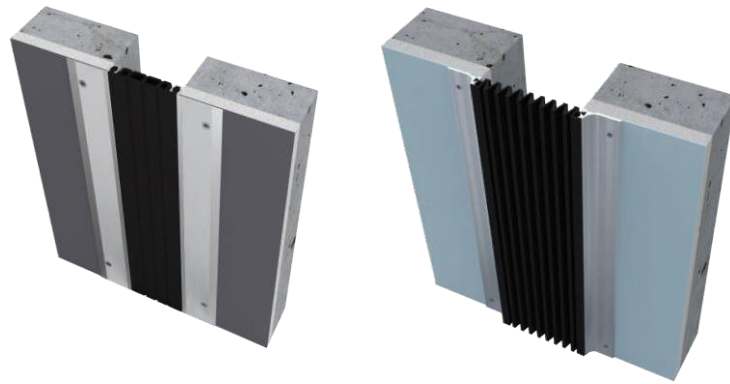

COLORES DE NUDILLOS
/ GASKET COLOURS:

NEGRO **GRIS** **CREMA**
BLACK GREY CREAM

» COR_080_262

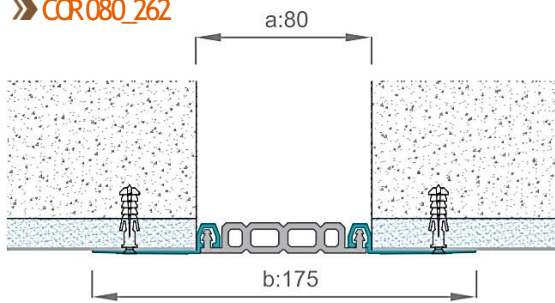

» COR_100_262

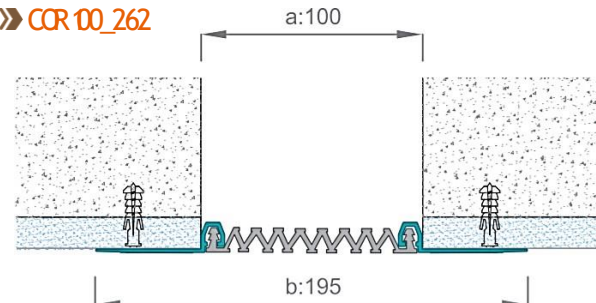

» COR_100_252

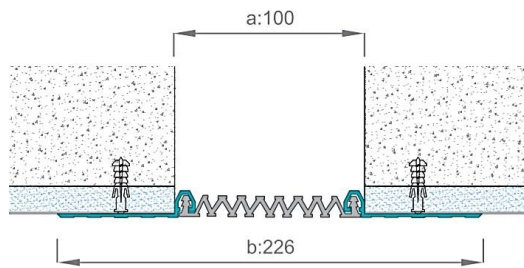

» COR_100_295

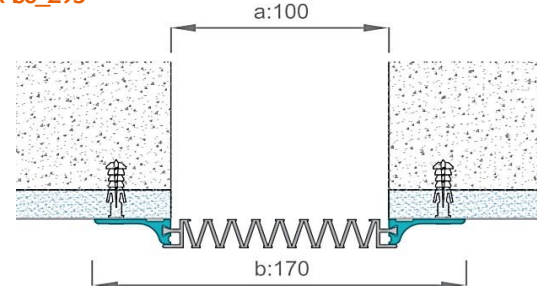

Tipo de junta de pared y
techo
gasket type: floor, wall,
Ceiling profiles

Las juntas de expansión de pared y techo de superficie son adecuadas para distancias de 80 a 100 mm con opciones de unión alternativas. Utilizado para techos su alta capacidad de movimiento puede ser una alternativa a los perfiles sísmicos.

Surface mounted wall-ceiling expansion joint profiles are suitable for 80-100mm gap with alternative gasket options. Used for ceilings and its high movement capacity can be an alternative to seismic profiles.



REF	DESCRIPCIÓN DESCRIPTION	ANCHO CONJUNTO (a) mm JOINT WIDTH	SUPERFICIE VISIBLE (b) mm SURFACE VISIBLE	ALTURA PERFIL (h) mm PROFILE HEIGHT	ANCHO TOTAL (s) mm TOTAL WIDTH	SUPERFICIE SURFACE	CAPACIDAD DE MOVIMIENTO MOVEMENT CAPACITY
COR_080_262	Anodizado, atornillado, decorativo, económico. Anodised, screw-headed, decorative, economic.	80	175	12	175	Alu anodizado + TPE Anodised ALU + TPE	± 10
COR_100_252	Superficie superior ancha anodizada. Anodised wide top surface.	100	226	12	226	Alu anodizado + TPE Anodised ALU + TPE	± 50
COR_100_254	Junta de pared - recubrimiento de acabado. Mill finish wall-ceiling profile.	100	188	14	188	Acabamento Alu + TPE Mill finish ALU + TPE	± 50
COR_100_255	Acabado superficial superior ancho. Mill finish wide top surface.	100	250	14	250	Acabamento Alu + TPE Mill finish ALU + TPE	± 50
COR_100_261	Anodizado, perforado en tornillo, decorativo. Anodised, screw-headed, decorative.	100	195	12	195	Alu anodizado + TPE Anodised ALU + TPE	± 50
COR_100_262	Anodizado, atornillado, decorativo, económico. Anodised, screw-headed, decorative, economic.	100	195	12	195	Alu anodizado + TPE Anodised ALU + TPE	± 50
COR_101_262	Adecuado para aislamiento térmico de fachadas, etc. (shell plano). Suitable for heat insulation and facade and etc. (flat gasket).	100	195	12	195	Alu anodizado + TPE Anodised ALU + TPE	± 16
COR_102_262	Adecuado para zonas interiores y fachada. (sísmica). Suitable with internal areas and facade (seismic).	100	190	12	190	Alu anodizado + TPE Anodised ALU + TPE	± 14
COR_100_295	Adecuado para solado, cerámica, yeso y etc. Suitable for screed, ceramic, dry wall board etc.	100	170	14	170	Acabamento Alu + TPE Mill finish ALU + TPE	+ 100 / - 60

Juntas de pared y techo montadas en superficie
Surface mounted wall and ceiling profiles

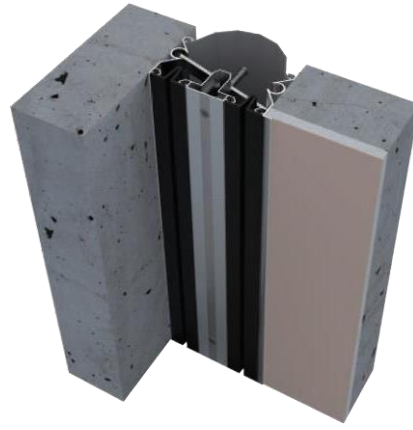

COLORES DE NUDILLOS
/ GASKET COLOURS

NEGRO
BLACK
GRIS
GREY
CREMA
CREAM

» **COR 150_285**

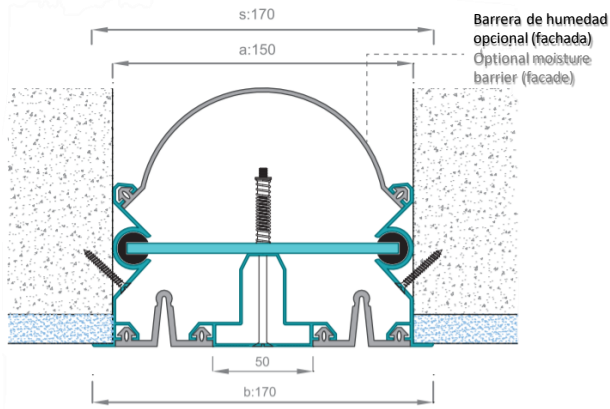

» **COR 150K_285**

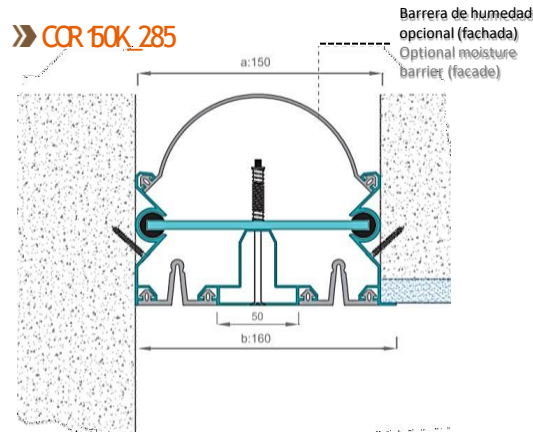

» **COR 200_285**

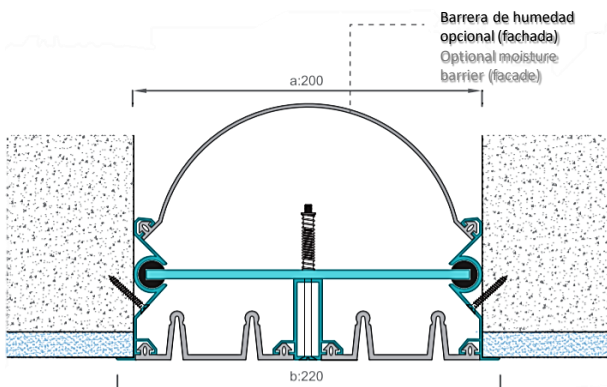

» **COR 150_295**

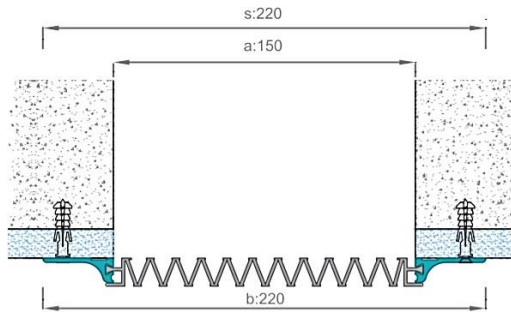

Tipo de junta de pared y
techo
gasket type: floor, wall,
ceiling profiles

Las juntas de expansión con acabado inferior y superior, se utilizan para distancias más grandes (150-200-250 mm). Decorativo y adecuado para movimientos altos. También se puede utilizar en la fachada de las estructuras.

Under and over finish expansion joint profiles are suitable for larger gaps (150-200-250mm). Decorative and suitable for high movements. Can also be used at facade of the structures.



REF	DESCRIPCIÓN DESCRIPTION	ANCHO CONJUNTO (a) mm JOINT WIDTH	SUPERFICIE VISIBLE (b) mm SURFACE VISIBLE	ALTURA PERFIL (h) mm PROFILE HEIGHT	ANCHO TOTAL (s) mm TOTAL WIDTH	SUPERFICIE SURFACE	CAPACIDAD DE MOVIMIENTO MOVEMENT CAPACITY
COR_150_285	Adecuado para zonas interiores o exteriores (sísmicas) Suitable for internal or external areas (seismic)	150	170	130	170	Acabamento Alu + TPE Mill finish ALU + TPE	± 75
COR_150_295	Acabado de fresado, agujeros de tornillo, acordeón sellado Mill finish, screw holes, accordion gasketed	150	220	14	220	Acabamento Alu + TPE Mill finish ALU + TPE	+130/-90
COR_200_285	Adecuado para zonas interiores o exteriores (sísmicas) Suitable for internal or external areas (seismic)	200	220	130	220	Acabamento Alu + TPE Mill finish ALU + TPE	± 100
COR_200_295	Acabado de fresado, agujeros de tornillo, acordeón sellado Mill finish, screw holes, accordion gasketed	200	270	14	270	Acabamento Alu + TPE Mill finish ALU + TPE	+200/-130



» CCR500_01

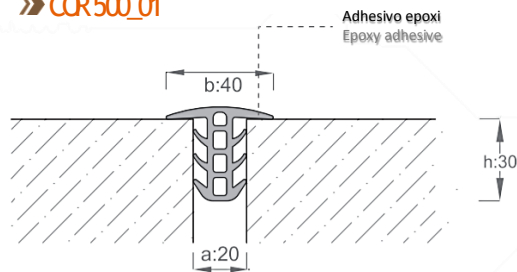

» CCR500_01

SOLICITUD DE ESQUINA / CORNER APPLICATION

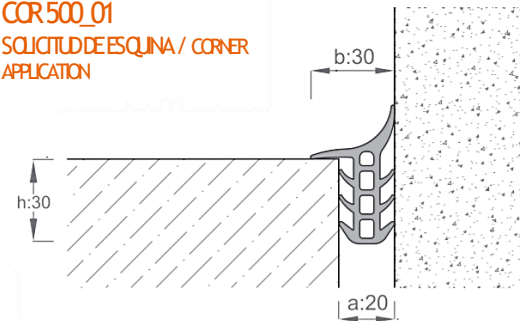

» CCR500_01A

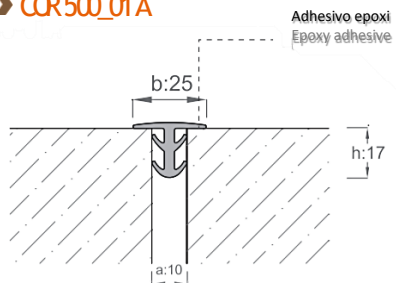

» CCR500_02

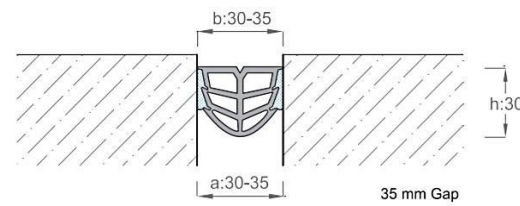

Tipo de junta de pared y
techo
gasket type: floor, wall,
Ceiling profiles

» CCR500_01B

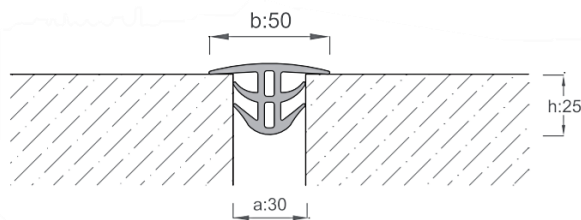

» CCR500_02A

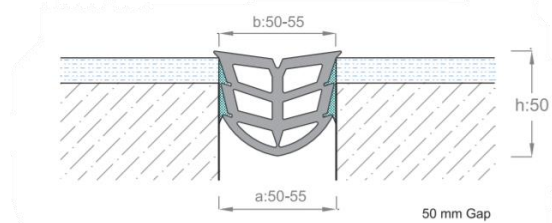

» CCR500_01C

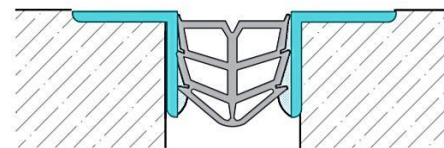
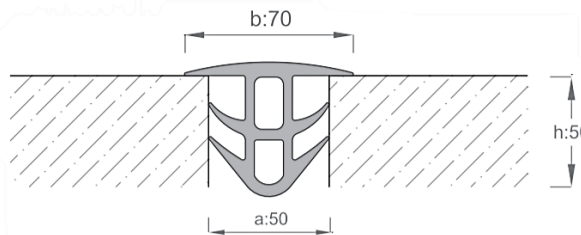

50 mm gap for stainless steel corner

Perfiles TPE, TPV (opcional) elaborados desde cero y adecuados para elementos prefabricados, fachadas, aplicaciones de pared seca y aplicaciones de laminado compactado. Fácil y práctico en el montaje.

TPE, TPV (optional) profiles made from scratch and suitable for precast elements, facade, drywall applications and compacted laminate applications. Easy and practical on assembly.



Juntas para elastómero termoplástico
Profiles for thermoplastic elastomer



» CCR500_05

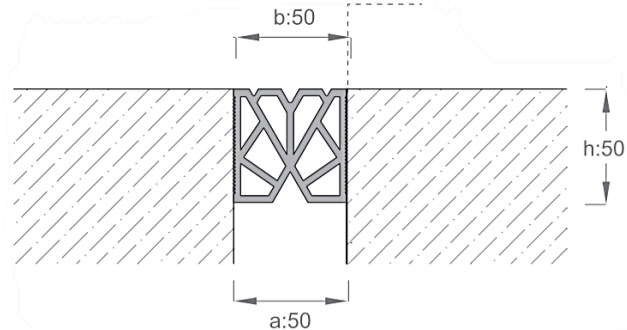

» CCR500_05

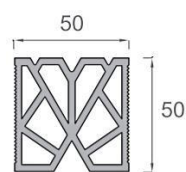

» CCR500_06

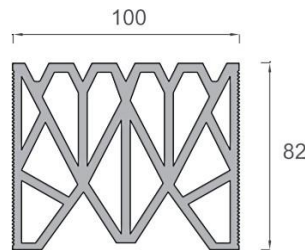

» CCR500_07

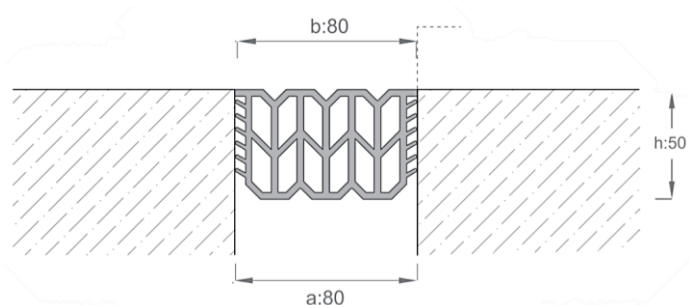

» CCR500_03

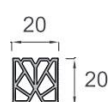

» CCR500_04

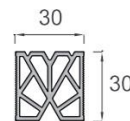

» CCR500_51

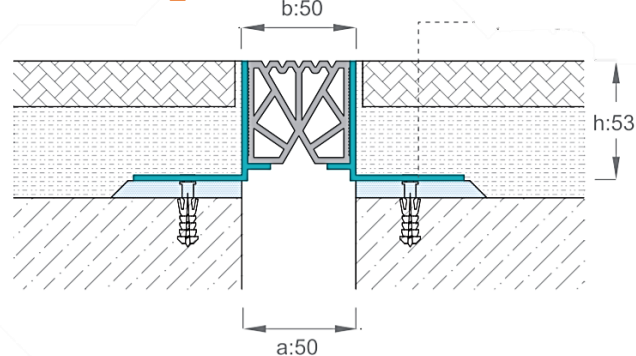

» CCR Ø3_050

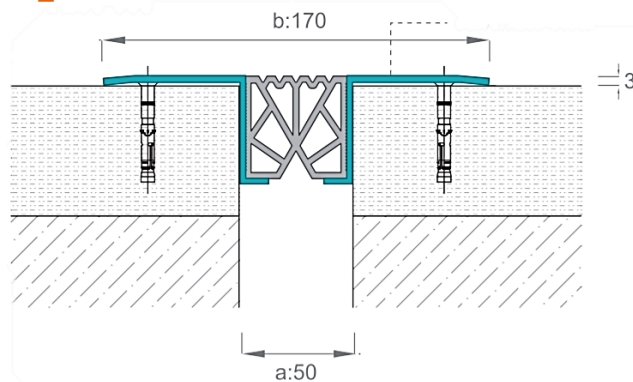

Tipos de juntas para el pavimento
techo
gasket type floor, wall,
ceiling and roof

Los productos hechos de material de elastómero termoplástico son adecuados para rangos de 30, 50, 100 mm y utilizados en suelos, paredes y techos.

Products made from thermoplastic elastomer material are suitable for 30, 50, 100mm gaps and used in floors, walls and ceilings.

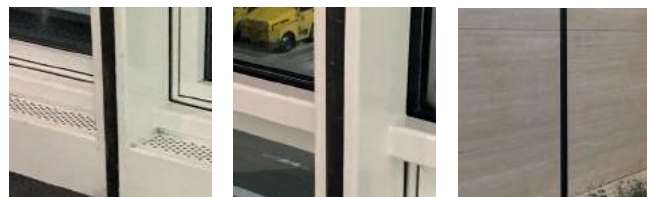

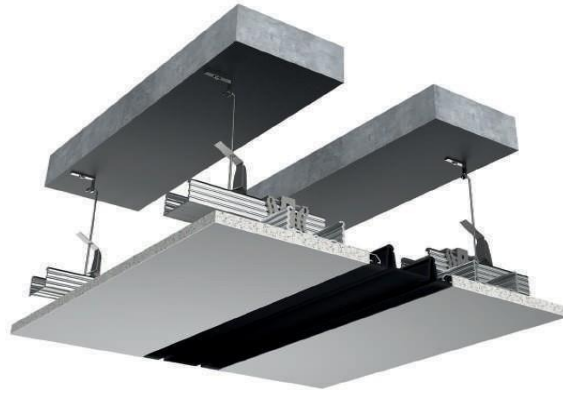

COLORES DE NUDILLOS / GASKET COLOURS

- NEGRO**
BLACK
- GRIS**
GREY
- CREMA**
CREAM

» **CORAR287_050**

» **CORAR287_100**

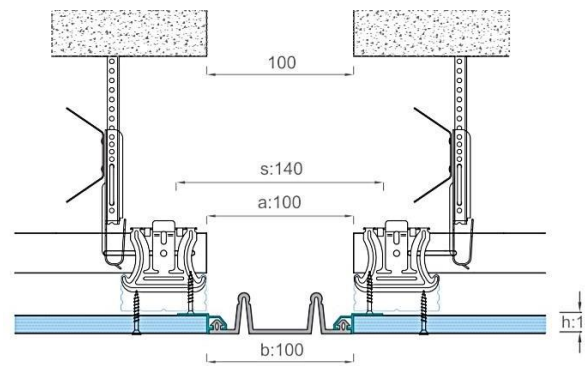
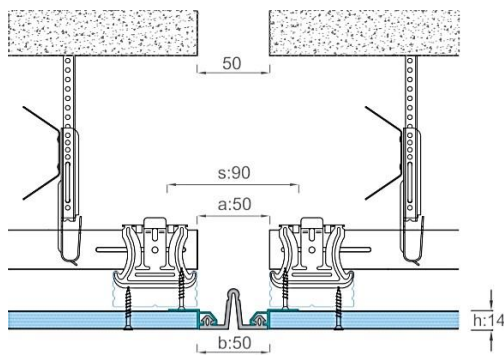

Tipo de junta de pared y techo
gasket type: floor, wall, ceiling profiles

» **CORARF50**

» **CORAR60DT**

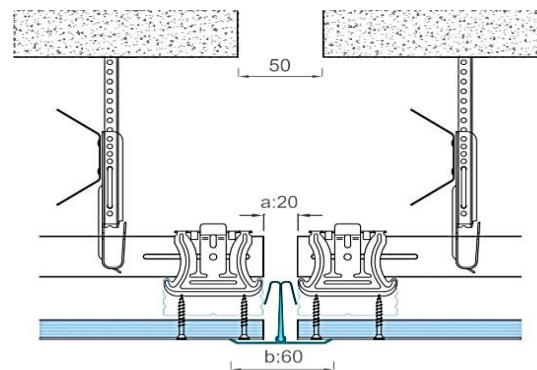
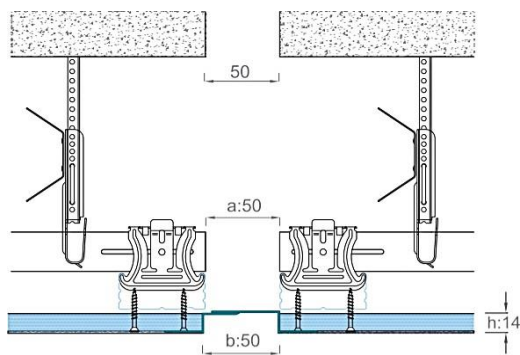

Junta de expansión de techo suspendido utilizada para varios tipos de techo suspendido. Son decorativos y vienen con juntas o perfiles enteramente en aluminio.
Suspended ceiling expansion joint profiles used for various types of suspended ceilings. They are decorative and come with gasket or fully aluminum profiles.



REF	DESCRIPCIÓN DESCRIPTION	ANCHO CONJUNTO (a) mm JOINT WIDTH	SUPERFICIE VISIBLE (b) mm SURFACE VISIBLE	ALTURA PERFIL (h) mm PROFILE HEIGHT	ANCHO TOTAL (s) mm TOTAL WIDTH	SUPERFICIE SURFACE	CAPACIDAD DE MOVIMIENTO MOVEMENT CAPACITY
COR_050287	Adecuado para zonas interiores o exteriores (sísmicas) Suitable for internal or external areas (seismic)	50	50	14	90	Acabamento Alu + TPE Mill finish ALU + TPE	± 25
COR_100287	Acabado de fresado, agujeros de tornillo, acordeón sellado. Mill finish, screw holes, accordion gasketed	100	100	14	140	Acabamento Alu + TPE Mill finish ALU + TPE	± 75
COR_ARF50	Adecuado para zonas interiores o exteriores (sísmica) Suitable for internal or external areas (seismic)	50	50	14	100	Aluminio anodizado. Anodised ALU	± 15
COR_AR60DT	Acabado de fresado, agujeros de tornillo, acordeón sellado. Mill finish, screw holes, accordion gasketed	20	60	-	60	Aluminio anodizado. Anodised ALU	± 15

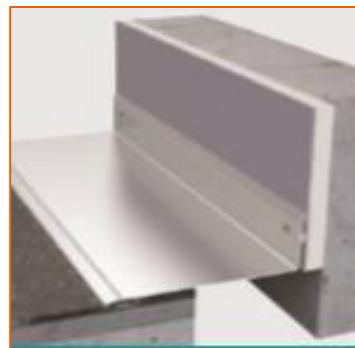

Juntas de suelo, pared, techo, techo
Floor, wall, ceiling, cover profiles



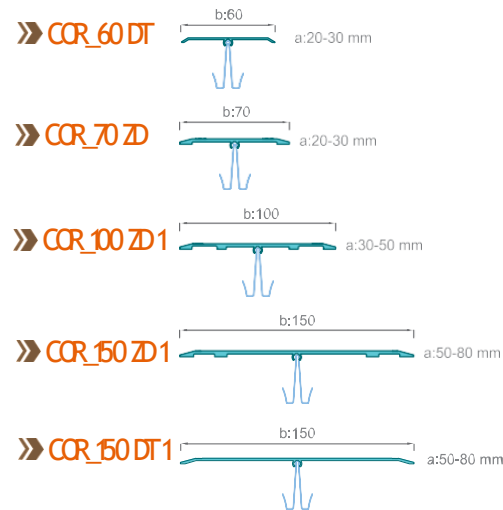
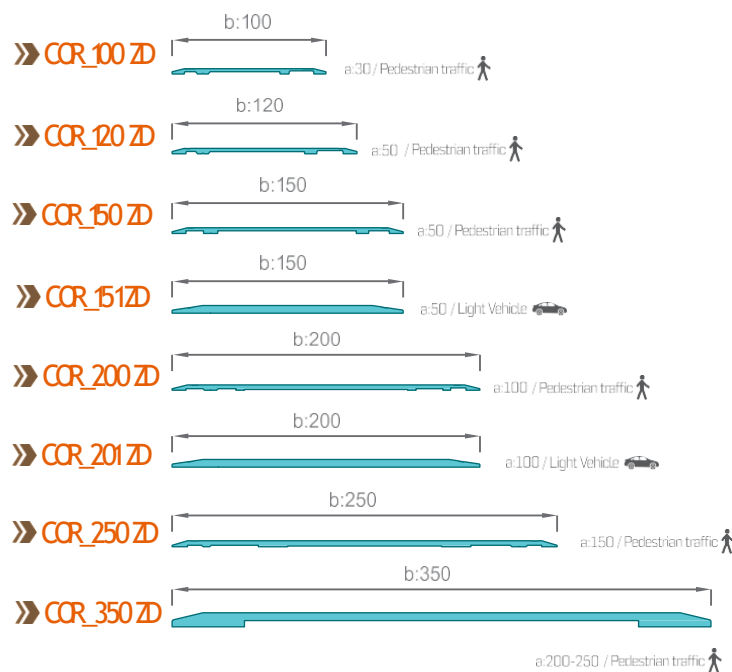
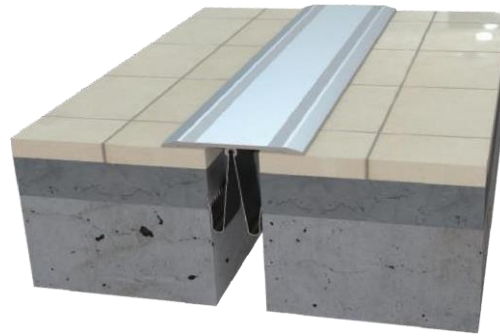

Tipo de junta de pared y
techo
gasket type floor, wall,
Ceiling profiles

Se puede aplicar con el sistema de clip (sin necesidad de tornillos) en intervalos de tamaño estándar.

Can be applied with clips system (without needing screws) to standard dimensioned gaps.

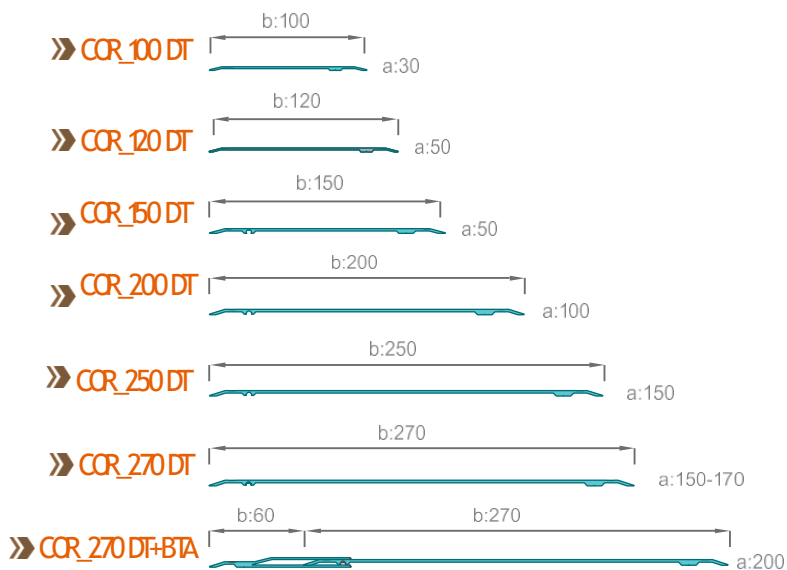

Práctico en el montaje con un orificio lateral. Las uniones de techo anodizados se pueden aplicar fácilmente a suelos, paredes y techos.

Practical on assembly with one side screw hole. Anodized cover profiles can easily be applied to floors, walls and ceilings.

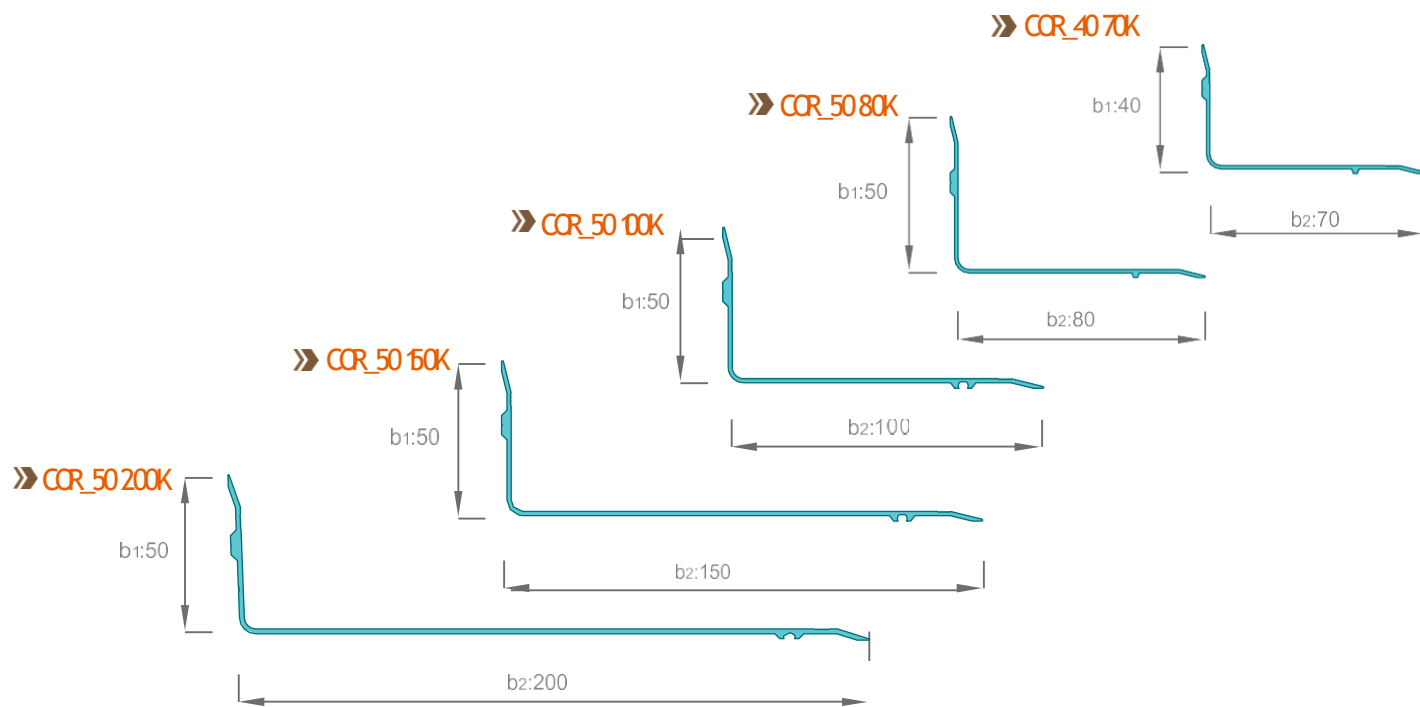
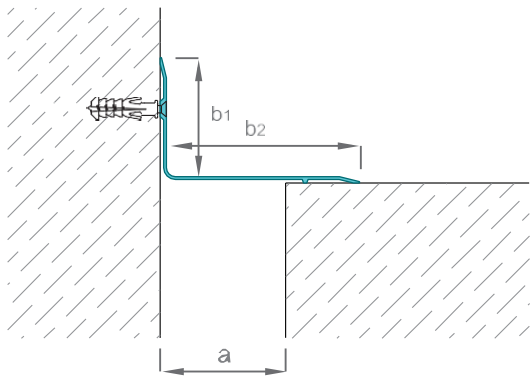

Tipo de junta de pared y
techo
gasket type floor, wall,
ceiling profiles

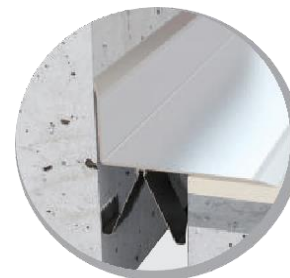
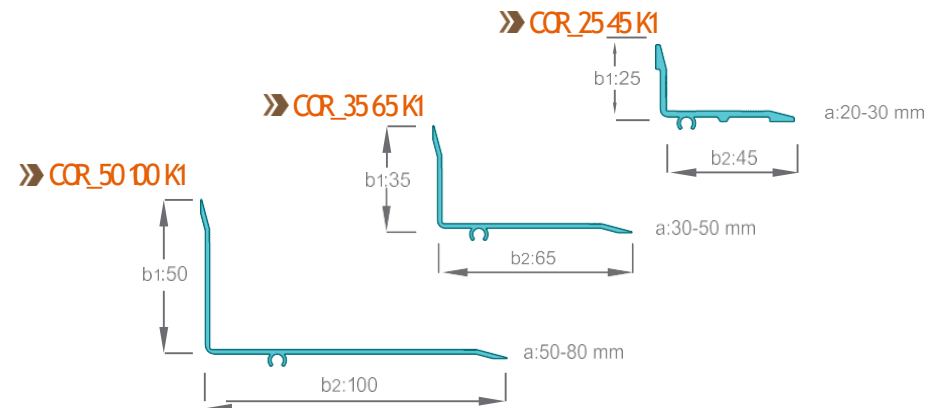
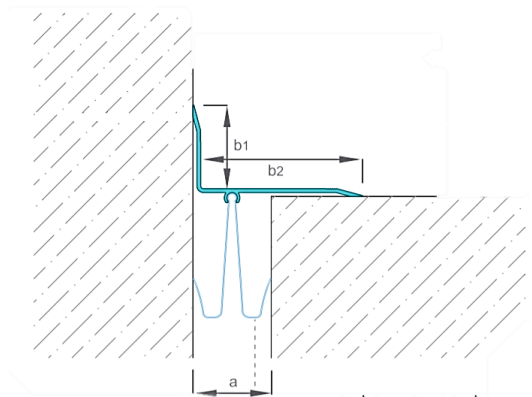

La junta de cubierta de esquina es compatible con juntas rectas y se utiliza en suelos, paredes y techos.
Corner cover profile are compatible with straight cover profiles and used in floors, walls and ceilings.



» CCR_151DT

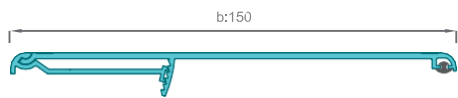

» CCR_201DT

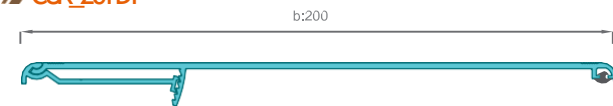

» CCR_50 01K

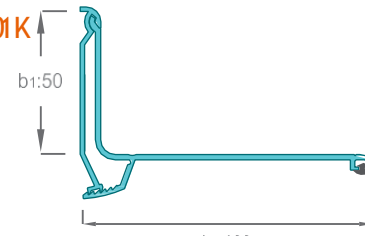

» CCR_50 151K

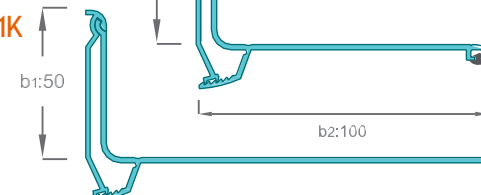

» CCR_50 201K

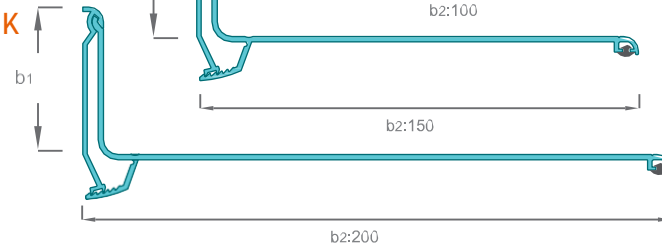

Tipologia de junta de cobertura
gasket type floor, wall,
ceiling profiles

JUNTAS DE CUBIERTA DE ACERO INOXIDABLE / STAINLESS STEEL COVER PROFILES

» CCR_100 ZS



» CCR_120 ZS

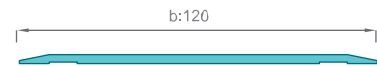

» CCR_150 ZS

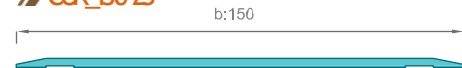

» CCR_200 ZS



» CCR_100 DS

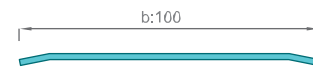

» CCR_120 DS

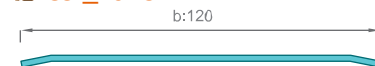

» CCR_150 DS



» CCR_200 DS



» CCR_40 80ZKS

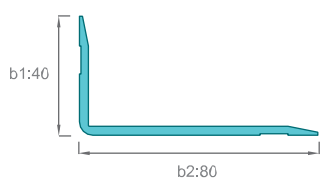

» CCR_40 80DKS

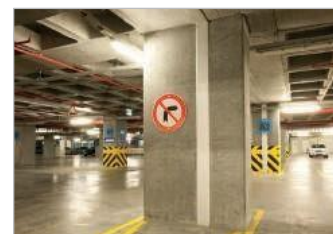
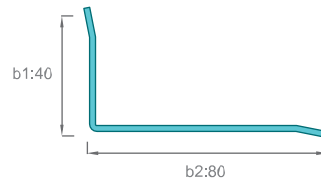

Juntas de suelo, pared y techo
300 COR series Floor, wall, and ceiling profiles

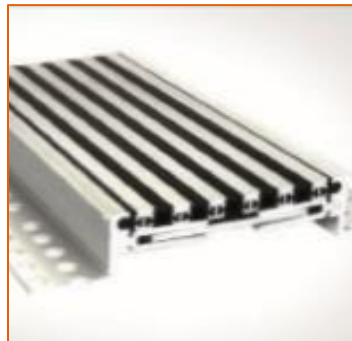

Juntas de expansión de suelos incrustados.
Flush mounted floor expansion joint profiles



» CCR_035 300

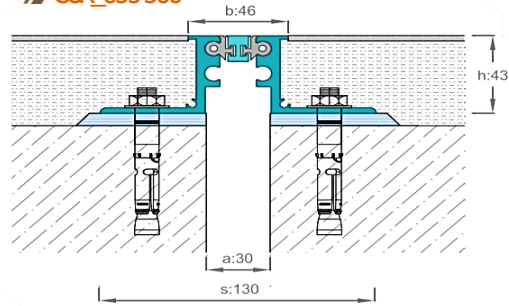

» CCR_050 301

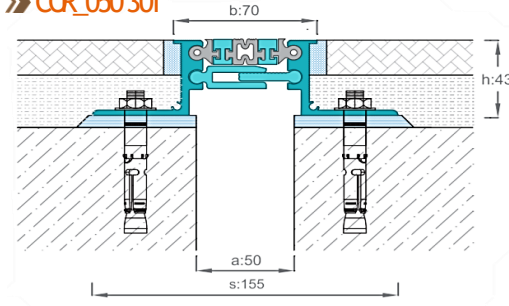

» CCR_05B 301

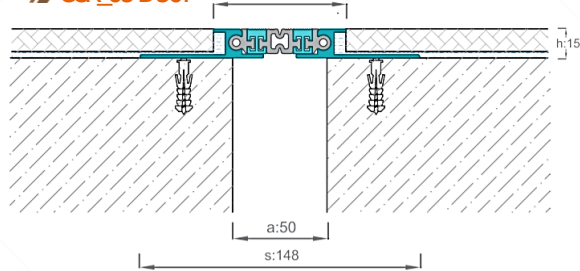

» CCR_050K 301

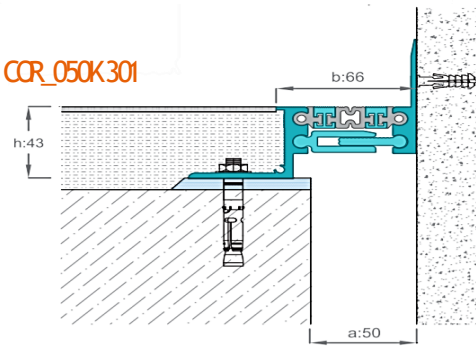

300 series de suelo,
pared y techo
300 series floor, wall,
Ceiling profiles

» CCR_05B 301



» CCR_051301



» CCR_052 301



» CCR_050 301



» CCR_053 301



» CCR_054 301

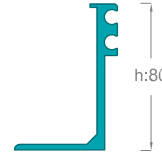

Las juntas de expansión de la serie 300 consisten en juntas de aluminio lamelas y TPE. La serie COR 300 se puede utilizar en áreas como centros comerciales, edificios industriales ligeros, almacenes, hospitales, aeropuertos y medidores expuestos a vehículos medianos y carga peatonal pesada. Es adecuado para muchos tipos de suelos, como cerámica, granito, mármol, suelo y suelos industriales con varias alturas de pies. Premontado y preparado en 3 metros de largo para entrega. Se fija al suelo con anclajes con espaciado de 35 cm en ambos lados.

The 300 series dilatation profiles consisting of aluminum lamellae and TPE gaskets. The 300 series can be used in areas such as shopping malls, light industrial buildings, warehouses, hospitals, airports and subways which are exposed to medium vehicle and intense pedestrian load. It is suitable for many flooring types such as, ceramic, granite, marble, screed and industrial floors with various foot heights. Pre-mounted and prepared in 3 meters lengths for delivery. It is fixed to the floor with anchors with 35cm spacing on both sides.



REF	DESCRIPCIÓN DESCRIPTION	ANCHO CONJUNTO (a) mm JOINT WIDTH	SUPERFICIE VISIBLE (b) mm SURFACE VISIBLE	ALTURA PERFIL (h) mm PROFILE HEIGHT	ANCHO TOTAL (s) mm TOTAL WIDTH	SUPERFICIE SURFACE	CAPACIDAD DE MOVIMIENTO MOVEMENT CAPACITY	CAPACIDAD DE CARGA LOAD CAPACITY
COR_035 300	Es necesario especificar la altura del pie. Foot height is required to be specified.	30	46	14/28/43/60/80	130	Acabamento Alu + TPE Mill finish ALU + TPE	+ 5	30 Ton 6,5 Ton
COR_050 301	Adecuado con solado, granito, mármol y, etc. Suitable with screed, granite, marble and etc.	50	70	43	155	Acabamento Alu + TPE Mill finish ALU + TPE	+ 10	15 Ton 3,5 Ton
COR_051 301	Adecuado con cerámica. Suitable with ceramic.	50	70	14	155	Acabamento Alu + TPE Mill finish ALU + TPE	+ 10	+ 1,5 Ton
COR_051B 301	Adecuado con cerámica y económico. Suitable with ceramic and economic.	50	70	15	148	Acabamento Alu + TPE Mill finish ALU + TPE	+ 10	
COR_052 301	Adecuado con granito natural, mármol y, etc. Suitable with natural granite, marble and etc.	50	70	28	155	Acabamento Alu + TPE Mill finish ALU + TPE	± 10	2,5 Ton
COR_053 301	Adecuado con solado, granito, mármol y, etc. Suitable with screed, granite, marble and etc.	50	70	60	155	Acabamento Alu + TPE Mill finish ALU + TPE	± 10	15 Ton 3,5 Ton
COR_054 301	Adecuado con solado, granito, mármol y, etc. Suitable with screed, granite, marble and etc.	50	70	80	155	Acabamento Alu + TPE Mill finish ALU + TPE	+ 10	15 Ton 3,5 Ton

Junta de expansión de suelo incrustado
Flush mounted floor expansion joint profiles



» COR_100_303

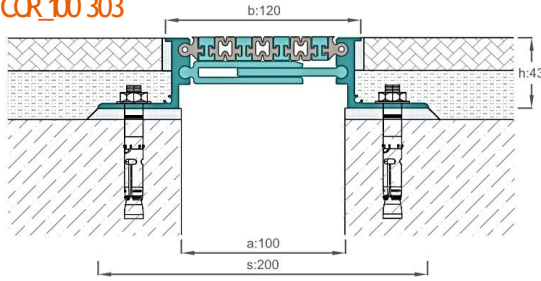

» COR_100k_303

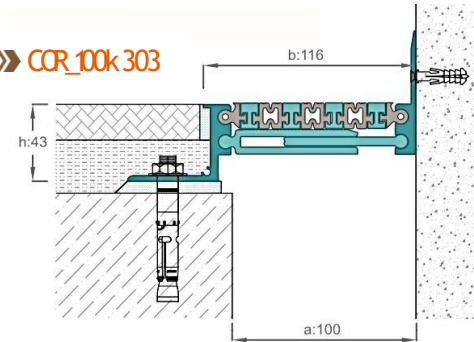

» COR_01_303

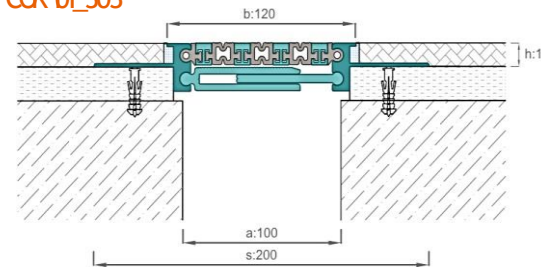

» COR_00_304

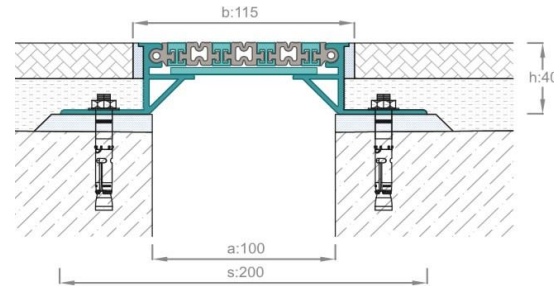

300 series de suelo,
pared y techo
300 series floor, wall,
Ceiling profiles

» COR_04_303

» COR_04_303

» COR_01B_303



» COR_01_303



» COR_02_303



» COR_00_303



» COR_03_303

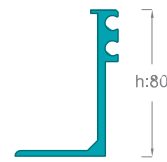

Las series COR 303 y 304 se pueden utilizar en todo tipo de edificios, como centros comerciales, hospitales, edificios gubernamentales y centros de negocios. También se pueden utilizar en zonas expuestas al tráfico vehicular con una altura mínima de 43 mm.
303 and 304 series can be used in all kinds of buildings such as shopping centers, hospitals, government buildings and business centres. These can also be used in areas exposed to vehicle traffic with minimum height of 43mm.

REF	DESCRIPCIÓN DESCRIPTION	ANCHO CONJUNTO (a) mm JOINT WIDTH	SUPERFICIE VISIBLE (b) mm SURFACE VISIBLE	ALTURA (h) mm PROFILE HEIGHT	ANCHO (s) mm TOTAL WIDTH	SUPERFICIE SURFACE	CAPACIDAD DE MOVIMIENTO MOVEMENT CAPACITY	CAPACIDAD DE CARGA LOAD CAPACITY
COR_081_302	Adecuado con cerámica. Suitable with ceramic.	80	100	14	185	Acabamento Alu + TPE Mill finish ALU + TPE	± 12	
COR_081B_302	Adecuado con cerámica y económico. Suitable with ceramic and economic.	80	100	15	178	Acabamento Alu + TPE Mill finish ALU + TPE	± 12	
COR_082_302	Adecuado con granito natural, mármol y etc. Suitable with natural granite, marble, etc.	80	100	28	185	Acabamento Alu + TPE Mill finish ALU + TPE	± 12	
COR_080_302	Adecuado con granito natural, mármol y etc. Suitable with natural granite, marble, etc.	80	100	43/60/80	185	Acabamento Alu + TPE Mill finish ALU + TPE	± 12	
COR_101_303	Adecuado con cerámica. Suitable with ceramic.	100	120	14	200	Acabamento Alu + TPE Mill finish ALU + TPE	± 15	
COR_101B_303	Adecuado con cerámica y económico. Suitable with ceramic and economic.	100	120	15	193	Acabamento Alu + TPE Mill finish ALU + TPE	± 15	
COR_102_303	Adecuado con granito natural, mármol y etc. Suitable with natural granite, marble, etc.	100	120	28	200	Acabamento Alu + TPE Mill finish ALU + TPE	± 15	
COR_100_303	Adecuado con granito natural, mármol y etc. Suitable with natural granite, marble, etc.	100	120	43/60/80	200	Acabamento Alu + TPE Mill finish ALU + TPE	± 15	
COR_100_304	Adecuado con cerámica y económico. Suitable with ceramic and economic.	100	115	40	200	Acabamento Alu + TPE Mill finish ALU + TPE	± 15	

Junta de expansión de suelo incrustado
Flush mounted floor expansion joint profiles



» COR_150 303

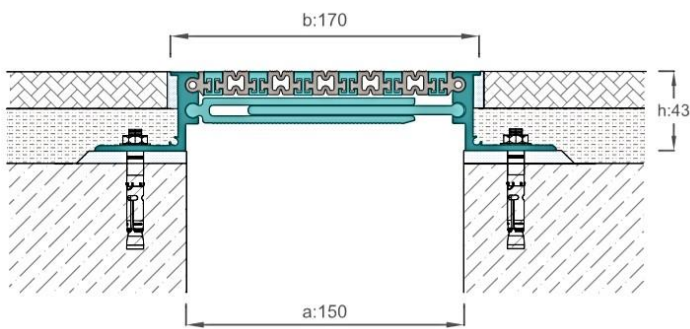

» COR_150K 303

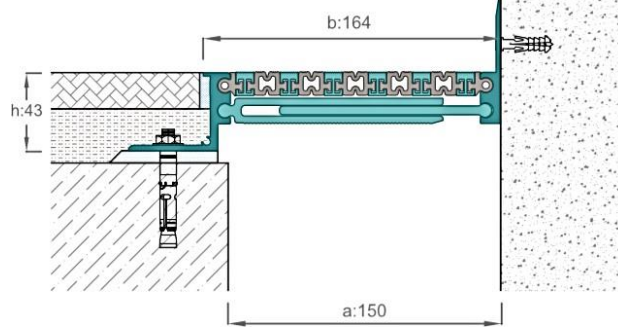

» COR_200 303

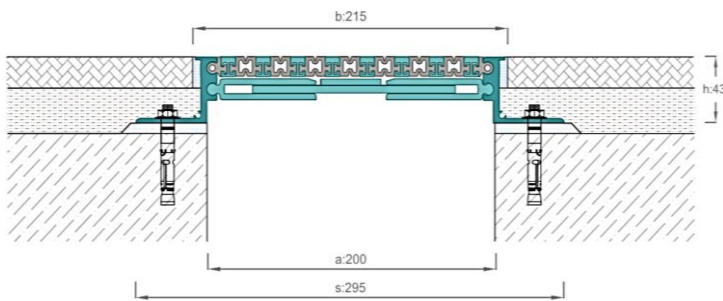

» COR_150 303



» COR_153 303



» COR_154 303



300 series de suelo,
pared y techo
300 series floor, wall,
Ceiling profiles

300 series de suelo,
pared y techo
300 series floor, wall,
Ceiling profiles

Las juntas de expansión de suelo de la serie COR 300 se utilizan para intervalos de 150 mm y 200 mm, se utilizan generalmente en áreas expuestas a la carga peatonal. Está montado con anclajes de acero y tornillos con espaciado de 35cm en ambos lados, montado y preparado en 3 metros de longitud.

The 300 series floor expansion joint profiles used for 150mm and 200mm gaps and generally utilized in areas exposed to pedestrian load. It is assembled with steel anchors and screws with 35cm spacing from both sides, Mounted and prepared in 3 meters lengths for delivery.



REF	DESCRIPCIÓN DESCRIPTION	ANCHO CONJUNTO (a) mm JOINT WIDTH	SUPERFICIE VISIBLE (b) mm SURFACE VISIBLE	ALTURA (h) mm PROFILE HEIGHT	ANCHO (s) mm TOTAL WIDTH	SUPERFICIE SURFACE	CAPACIDAD DE MOVIMIENTO MOVEMENT CAPACITY	CAPACIDAD DE CARGA LOAD CAPACITY
COR_150 303	Granito adecuado, mármol y, etc. Suitable with granite, marble, etc.	150	168	43,60,80	250	Acabamento Alu + TPE Mill finish ALU + TPE	± 25	
COR_200 303	Granito adecuado, mármol y, etc. Suitable with granite, marble, etc.	200	215	43,60,80	295	Acabamento Alu + TPE Mill finish ALU + TPE	± 35	

Junta de expansión de suelo incrustado
Flush mounted floor expansion joint profiles.



» CCR_50 308

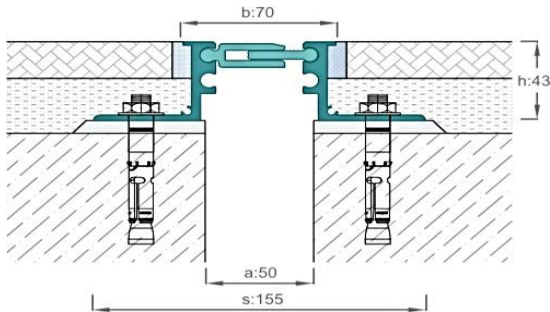

» CCR_100 309

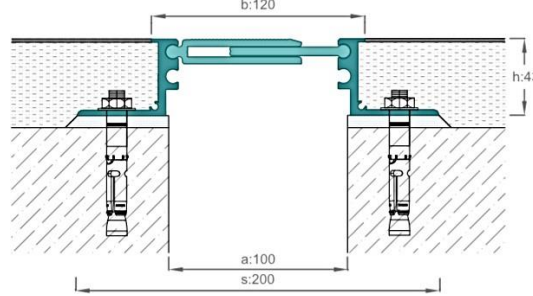

» CCR_150 309

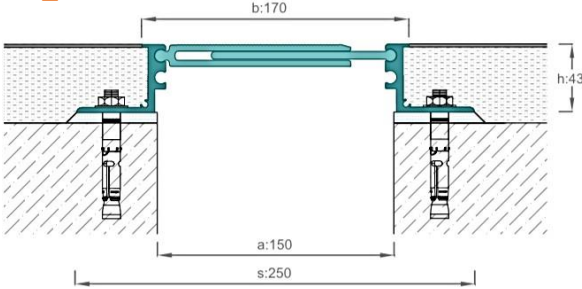

» CCR_160K 309

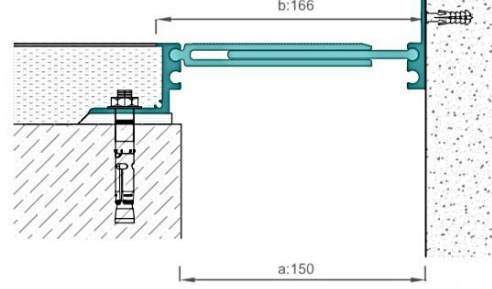

300 series de suelo,
pared y techo
300 series floor, wall,
Ceiling profiles



Las juntas de expansión horizontal y vertical de ambos acabados están completamente cubiertas en la superficie de aluminio.
Horizontally and vertically movable, decorative and economical under finish expansion joint profiles are fully covered in aluminum surface.



REF	DESCRIPCIÓN DESCRIPTION	ANCHO CONJUNTO (a) mm JOINT WIDTH	SUPERFICIE VISIBLE (b) mm SURFACE VISIBLE	ALTURA (h) mm PROFILE HEIGHT	ANCHO (s) mm TOTAL WIDTH	SUPERFICIE SURFACE	CAPACIDAD DE MOVIMIENTO MOVEMENT CAPACITY	CAPACIDAD DE CARGA LOAD CAPACITY
COR_051 308	Adecuado con cerámica. Suitable with ceramic.	50	70	14	155	Acabamento Alu Mill Finish ALU	± 10	
COR_052 308	Adecuado con granito natural, mármol y etc. Suitable with natural granite, marble etc.	50	70	28	155	Acabamento Alu Mill Finish ALU	± 10	
COR_050 308	Adecuado con solado de granito, mármol y etc Suitable with natural granite, marble etc.	50	70	43/60/80	155	Acabamento Alu Mill Finish ALU	± 10	
COR_080 309	Es necesario especificar la altura del pie Footing height is required to be specified.	80	100	14/28/43/60/80	185	Acabamento Alu Mill Finish ALU	± 12	
COR_100 309	Es necesario especificar la altura del pie Footing height is required to be specified.	100	120	14/28/43/60/80	200	Acabamento Alu Mill Finish ALU	± 15	
COR_150 309	Es necesario especificar la altura del pie Footing height is required to be specified.	150	170	43/60/80	250	Acabamento Alu Mill Finish ALU	± 25	

Junta de expansión de suelo de superficie
 Surface mounted floor expansion joint profiles

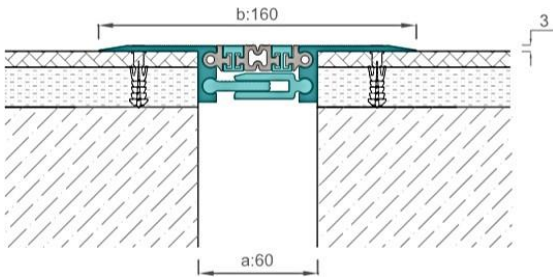

» COR_050 172

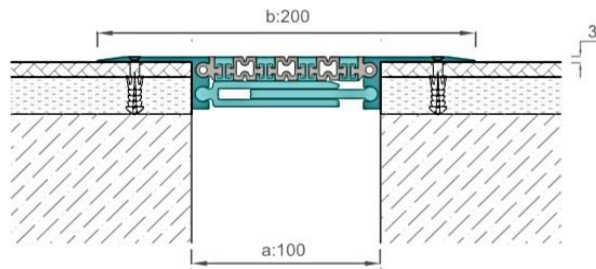

» COR_100 174

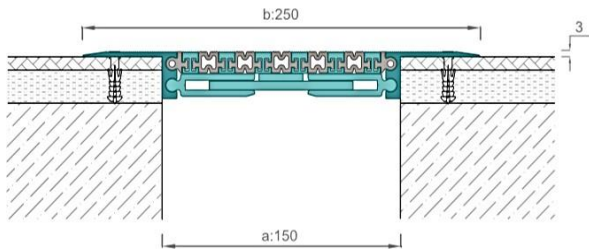

» COR_150 174





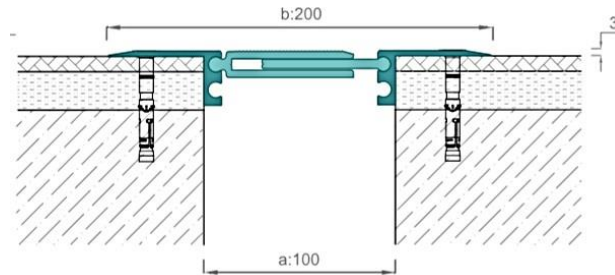









» COR_100 184

 300 series de suelo,
 pared y techo
 300 series floor, wall,
 Ceiling profiles

Estas juntas de expansión decorativas, son adecuadas para distancias de 35 mm a 200 mm, están provistas de agujeros en ambos lados. Las opciones de sellado TPE están disponibles en gris y negro.

Expansion joint profiles suitable for joint gaps from 35mm to 200mm. These decorative profiles come with screw holes on both sides. TPE gasket options available are at grey and black color.



REF	DESCRIPCIÓN DESCRIPTION	ANCHO CONJUNTO (a) mm JOINT WIDTH	SUPERFICIE VISIBLE (b) mm SURFACE VISIBLE	ALTURA (h) mm PROFILE HEIGHT	ANCHO (s) mm TOTAL WIDTH	SUPERFICIE SURFACE	CAPACIDAD DE MOVIMIENTO MOVEMENT CAPACITY	CAPACIDAD DE CARGA LOAD CAPACITY
COR_035 171	Adecuado con cerámica. Suitable with ceramic.					Acabamento Alu + TPE Mill finish ALU + TPE		 
COR_050 172	Adecuado con cerámica y económico. Suitable with ceramic and economic					Acabamento Alu + TPE Mill finish ALU + TPE		 
COR_080 173	Adecuado con granito natural, mármol y etc. Suitable with natural granite, marble etc.					Acabamento Alu + TPE Mill finish ALU + TPE		
COR_174 100	Adecuado con granito natural, mármol y etc. Suitable with natural granite, marble etc.					Acabamento Alu + TPE Mill finish ALU + TPE		
COR_174 150	Adecuado con cerámica. Suitable with ceramic.					Acabamento Alu + TPE Mill finish ALU + TPE		
COR_200 174	Adecuado con cerámica y económico. Suitable with ceramic and economic					Acabamento Alu + TPE Mill finish ALU + TPE		
COR_050 182	Adecuado con granito natural, mármol y etc. Suitable with natural granite, marble etc.					Acabamento Aluminio Mill finish Aluminium		
COR_080 183	Adecuado con granito natural, mármol y etc. Suitable with natural granite, marble etc.					Acabamento Aluminio Mill finish Aluminium		
COR_184 100	Adecuado con cerámica y económico Suitable with granite and economic					Acabamento Aluminio Mill finish Aluminium		
COR_150 184	Adecuado con cerámica y económico Suitable with granite and economic					Acabamento Aluminio Mill finish Aluminium		

Junta de expansión montada en pared/techo
Flush mounted wall and ceiling expansion joint profiles



» COR_030 208

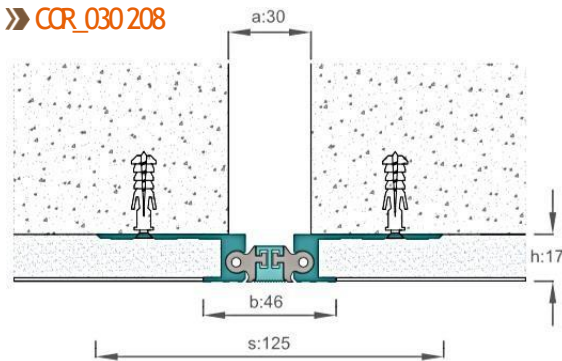

» COR_050 209

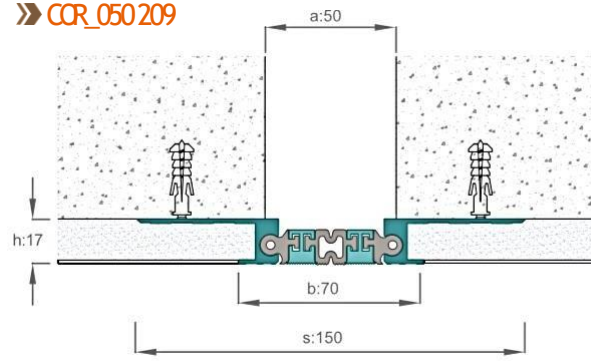

» COR_100 211

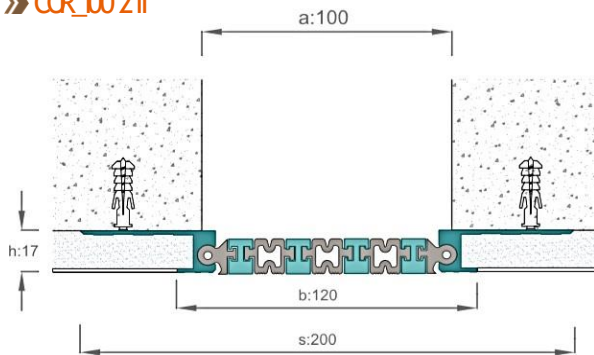

» COR_100 212

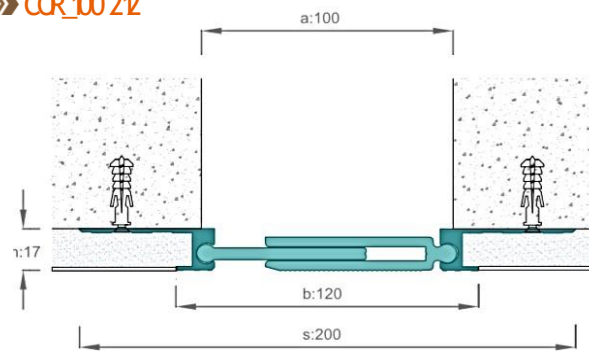

300 series de suelo,
pared y techo
300 series floor, wall,
ceiling profiles

Adaptable a paredes y techos compatibles con juntas de suelo de la serie COR 300. Se puede utilizar en revestimientos como yeso, cerámica y dry wall.
Adaptable to walls and ceilings which are compatible with COR 300 series floor profiles. Can be used in coverings such as, plaster, ceramic and dry wall.

REF	DESCRIPCIÓN DESCRIPTION	ANCHO CONJUNTO (a) mm JOINT WIDTH	SUPERFICIE VISIBLE (b) mm SURFACE VISIBLE	ALTURA PERFIL (h) mm PROFILE HEIGHT	ANCHO TOTAL (s) mm TOTAL WIDTH	SUPERFICIE SURFACE	CAPACIDADE MOVIMIENTO MOVEMENT CAPACITY
COR_030 208	Adecuado para solado, cerámica, placa de yeso / aluminio y superficie superior sellada Suitable with screed, ceramic, dry wall and etc / Aluminium & gasketed top surface	30	46	17	125	Acabamento Alu + TPE Mill finish ALU + TPE	± 5
COR_050 209	Adecuado para solado, cerámica, placa de yeso / aluminio y superficie superior sellada Suitable with screed, ceramic, dry wall and etc / Aluminium & gasketed top surface	50	70	17	150	Acabamento Alu + TPE Mill finish ALU + TPE	± 10
COR_080 210	Adecuado para solado, cerámica, placa de yeso / aluminio y superficie superior sellada Suitable with screed, ceramic, dry wall and etc / Aluminium & gasketed top surface	80	100	17	180	Acabamento Alu + TPE Mill finish ALU + TPE	± 12
COR_100 211	Adecuado para solado, cerámica, placa de yeso / aluminio y superficie superior sellada Suitable with screed, ceramic, dry wall and etc / Aluminium & gasketed top surface	100	120	17	200	Acabamento Alu + TPE Mill finish ALU + TPE	± 14
COR_150 211	Adecuado para solado, cerámica, placa de yeso / aluminio y superficie superior sellada Suitable with screed, ceramic, dry wall and etc / Aluminium & gasketed top surface	150	170	17	250	Acabamento Alu + TPE Mill finish ALU + TPE	± 25
COR_050 212	Adecuado para solado, cerámica, placa de yeso / superficie de aluminio Suitable with screed, ceramic, dry wall and etc / Aluminium top surface	50	70	17	150	Acabamento Aluminio Mill finish Aluminium	± 10
COR_080 212	Adecuado para solado, cerámica, placa de yeso / superficie de aluminio Suitable with screed, ceramic, dry wall and etc / Aluminium top surface	80	100	17	180	Acabamento Aluminio Mill finish Aluminium	± 12
COR_100 212	Adecuado para solado, cerámica, placa de yeso / superficie de aluminio Suitable with screed, ceramic, dry wall and etc / Aluminium top surface	100	120	17	200	Acabamento Aluminio Mill finish Aluminium	± 14
COR_150 212	Adecuado para solado, cerámica, placa de yeso / superficie de aluminio Suitable with screed, ceramic, dry wall and etc / Aluminium top surface	150	170	17	250	Acabamento Aluminio Mill finish Aluminium	± 25

Junta de expansión montada en pared/techo
Flush mounted wall and ceiling expansion joint profiles



» COR_030 258

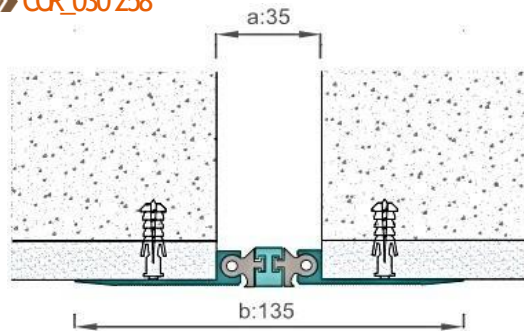

» COR_050 259

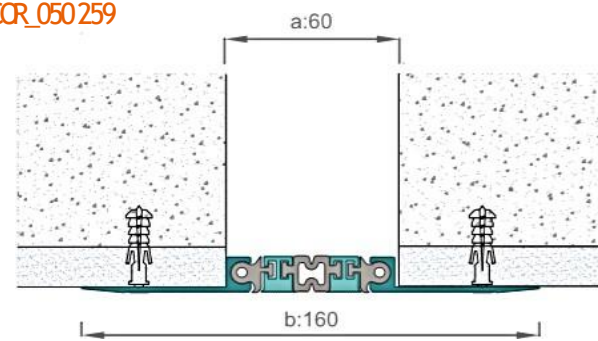

» COR_100 259

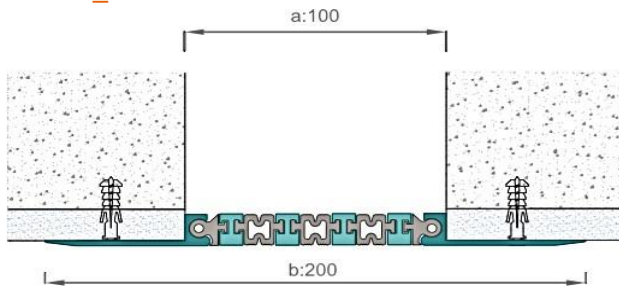

» COR_150 259

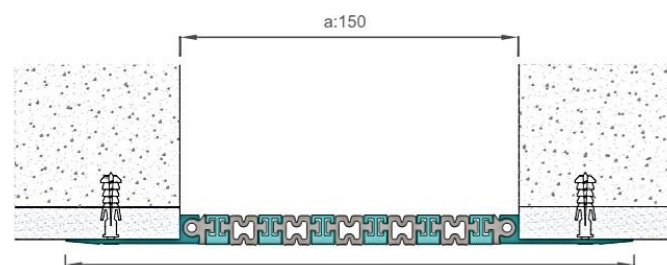

300 series de suelo,
pared y techo
300 series floor, wall,
ceiling profiles

Adecuado para paredes y techos compatibles con juntas de suelo de las series cor 300 y COR 172. Juntas de expansión montadas en superficie instaladas a partir de orificios de tornillo en ambos lados antes de la entrega.

Suitable for walls and ceilings which are compatible with COR 300 and COR 172 series floor profiles. Surface mounted expansion joint profiles fitted from screw holes on both sides before delivery.



REF	DESCRIPCIÓN DESCRIPTION	ANCHO CONJUNTO (a) mm JOINT WIDTH	SUPERFICIE VISIBLE (b) mm SURFACE VISIBLE	ALTURA PERFIL (h) mm PROFILE HEIGHT	ANCHO TOTAL (s) mm TOTAL WIDTH	SUPERFICIE SURFACE	CAPACIDAD DE MOVIMIENTO MOVEMENT CAPACITY
COR_030 258	Acabado fresado, colocado por tornillos, superficie superior de aluminio+ TPE/E Mill finish, screw holed, Alu+ TPE top surface	35	135	11	135	Acabamento Alu + TPE Mill finish ALU + TPE	± 5
COR_050 259	Acabado fresado, colocado por tornillos, superficie superior de aluminio+ TPE/E Mill finish, screw holed, Alu+ TPE top surface	60	160	11	160	Acabamento Alu + TPE Mill finish ALU + TPE	± 10
COR_080 259	Acabado fresado, colocado por tornillos, superficie superior de aluminio+ TPE Mill finish, screw holed, Alu + TPE top surface	80	180	11	180	Acabamento Alu + TPE Mill finish ALU + TPE	± 12
COR_100 259	Acabado fresado, colocado por tornillos, superficie superior de aluminio+ TPE/E Mill finish, screw holed, Alu+ TPE top surface	100	200	11	200	Acabamento Alu + TPE Mill finish ALU + TPE	± 14
COR_150 259	Acabado fresado, colocado por tornillos, superficie superior de aluminio+ TPE/E Mill finish, screw holed, Alu+ TPE top surface	150	250	11	250	Acabamento Alu + TPE Mill finish ALU + TPE	± 35
COR_200 259	Acabado fresado, colocado por tornillos, superficie superior de aluminio+ TPE Mill finish, screw holed, Alu + TPE top surface	200	300	11	300	Acabamento Aluminio Mill finish Aluminium	± 35



Juntas de suelo pesadas e higiénicas
Heavy duty and hygienic floor profiles

Junta de expansión de suelo incrustado
Flush mounted floor expansion joint profiles



»» COR_050 703

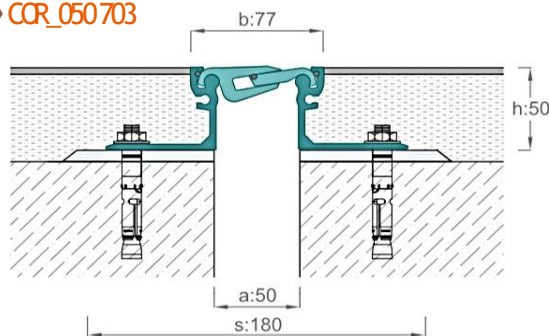

»» COR_050K 703

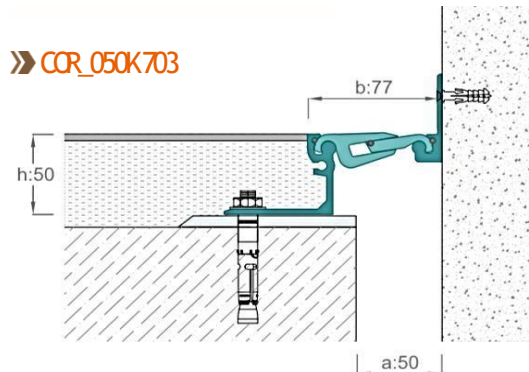

»» COR_050 700



»» COR_050 701



»» COR_050 702



»» COR_050 703



»» COR_050 704



»» COR_050 705

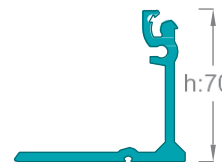

Juntas de suelo pesadas e higiénicas
Heavy duty and hygienic floor profiles

Las juntas de suelo de la serie 700 están diseñadas para ser decorativas, higiénicas y de servicio pesado con sección transversal superior especial; Juntas fiables a largo plazo se pueden utilizar en muchos proyectos diferentes, tales como centros comerciales, estructuras industriales pesadas, hospitales y aeropuertos, la longitud de producción es de 4 metros.

700 series floor to floor profiles are designed to be decorative, hygienic and resistant to heavy loads with special top cross section, long-term reliable profiles can be used in many different projects such as, shopping malls, heavy industrial structures, hospitals and airports, production length is 4 meters.



REF	DESCRIPCIÓN DESCRIPTION	ANCHO CONJUNTO (a) mm JOINT WIDTH	SUPERFICIE VISIBLE (b) mm SURFACE VISIBLE	ALTURA (h) mm PROFILE HEIGHT	ANCHO (s) mm TOTAL WIDTH	SUPERFICIE SURFACE	CAPACIDAD DE MOVIMIENTO MOVEMENT CAPACITY	CAPACIDAD DE CARGA LOAD CAPACITY
COR_050 700	Adecuado para centros comerciales, hospitales / superficie superior plana Suitable for shopping malls, Hospitals / Flat top surface	50	77	17	180	Acabamento Aluminio Mill finish Aluminium	± 10	3,5 Ton
COR_050 701	Adecuado para centros comerciales, hospitales / superficie superior plana Suitable for shopping malls, Hospitals / Flat top surface	50	77	30	180	Acabamento Aluminio Mill finish Aluminium	± 10	30 Ton 6,5 Ton
COR_050 702	Adecuado para centros comerciales, hospitales / superficie superior plana Suitable for shopping malls, Hospitals / Flat top surface	50	77	40	180	Acabamento Aluminio Mill finish Aluminium	± 10	30 Ton 6,5 Ton
COR_050 703	Adecuado para centros comerciales, hospitales / superficie superior plana Suitable for shopping malls, Hospitals / Flat top surface	50	77	50	180	Acabamento Aluminio Mill finish Aluminium	± 10	30 Ton 6,5 Ton
COR_050 704	Adecuado para centros comerciales, hospitales / superficie superior plana Suitable for shopping malls, Hospitals / Flat top surface	50	77	60	195	Acabamento Aluminio Mill finish Aluminium	± 10	30 Ton 6,5 Ton
COR_050 705	Adecuado para centros comerciales, hospitales / superficie superior plana Suitable for shopping malls, Hospitals / Flat top surface	50	77	70	195	Acabamento Aluminio Mill finish Aluminium	± 10	30 Ton 6,5 Ton
COR_080 710	Adecuado para centros comerciales, hospitales / superficie superior plana Suitable for shopping malls, Hospitals / Flat top surface	80	110	17	210	Acabamento Aluminio Mill finish Aluminium	± 16	2,5 Ton
COR_080 711	Adecuado para centros comerciales, hospitales / superficie superior plana Suitable for shopping malls, Hospitals / Flat top surface	80	110	30	210	Acabamento Aluminio Mill finish Aluminium	± 16	30 Ton 6,5 Ton
COR_080 712	Adecuado para centros comerciales, hospitales / superficie superior plana Suitable for shopping malls, Hospitals / Flat top surface	80	110	40	210	Acabamento Aluminio Mill finish Aluminium	± 16	30 Ton 6,5 Ton
COR_080 713	Adecuado para centros comerciales, hospitales / superficie superior plana Suitable for shopping malls, Hospitals / Flat top surface	80	110	50	210	Acabamento Aluminio Mill finish Aluminium	± 16	30 Ton 6,5 Ton



» COR_100 723

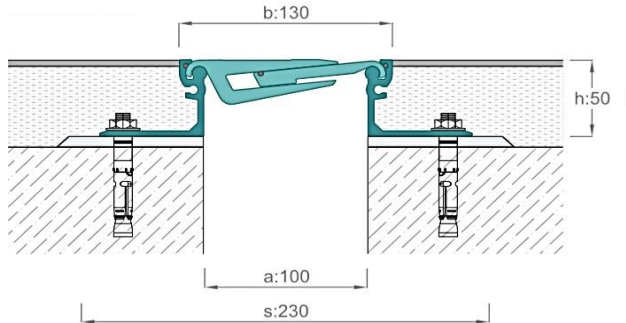

» COR_100K723

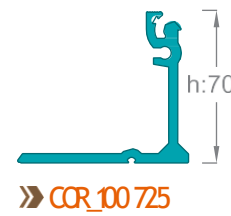
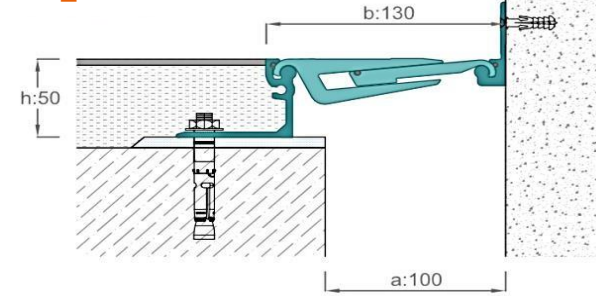

Juntas de suelo
pesadas e higiénicas
Heavy duty and
hygienic floor profiles

Adecuado para revestimientos de suelo como granito, mármol, cerámica, pavimento industrial y suelos de PVC con diferentes alturas de soporte. Montado en el suelo con anclajes de acero, con intervalos de 35 cm en ambos lados. El uso de mortero epoxi es un paso esencial para evitar posibles roturas que pueden ocurrir en los lados. Cada diseño tiene su opción de esquina disponible, fabricada como en el diseño de los detalles de unión T, L +.

Suitable for flooring covers such as granite, marble, ceramic, industrial screed and PVC floors with different footing heights. Assembled to the floor with steel anchors by having intervals of 35cm from both sides. Using epoxy mortar is an essential step to avoid any possible breakage which can occur at sides. Each design has its corner option available manufactured as in design of T, L + joining detail.



REF	DESCRIPCIÓN DESCRIPTION	ANCHO CONJUNTO (a) mm JOINT WIDTH	SUPERFICIE VISIBLE (b) mm SURFACE VISIBLE	ALTURA (h) mm PROFILE HEIGHT	ANCHO (s) mm TOTAL WIDTH	SUPERFICIE SURFACE	CAPACIDAD DE MOVIMIENTO MOVEMENT CAPACITY	CAPACIDAD DE CARGA LOAD CAPACITY
COR_080 714	Adecuado para centros comerciales, hospitales / superficie superior plana Suitable for shopping malls, Hospitals / Flat top surface	80	110	60	225	Acabamento Aluminio Mill finish Aluminium	± 16	30 Ton 6,5 Ton
COR_080 715	Adecuado para centros comerciales, hospitales / superficie superior plana Suitable for shopping malls, Hospitals / Flat top surface	80	110	70	225	Acabamento Aluminio Mill finish Aluminium	± 16	30 Ton 6,5 Ton
COR_100 720	Adecuado para centros comerciales, hospitales / superficie superior plana Suitable for shopping malls, Hospitals / Flat top surface	100	130	17	230	Acabamento Aluminio Mill finish Aluminium	± 20	
COR_100 721	Adecuado para centros comerciales, hospitales / superficie superior plana Suitable for shopping malls, Hospitals / Flat top surface	100	130	30	230	Acabamento Aluminio Mill finish Aluminium	± 20	30 Ton 6,5 Ton
COR_100 722	Adecuado para centros comerciales, hospitales / superficie superior plana Suitable for shopping malls, Hospitals / Flat top surface	100	130	40	230	Acabamento Aluminio Mill finish Aluminium	± 20	30 Ton 6,5 Ton
COR_100 723	Adecuado para centros comerciales, hospitales / superficie superior plana Suitable for shopping malls, Hospitals / Flat top surface	100	130	50	230	Acabamento Aluminio Mill finish Aluminium	± 20	30 Ton 6,5 Ton
COR_100 724	Adecuado para centros comerciales, hospitales / superficie superior plana Suitable for shopping malls, Hospitals / Flat top surface	100	130	60	245	Acabamento Aluminio Mill finish Aluminium	± 20	30 Ton 6,5 Ton
COR_100 725	Adecuado para centros comerciales, hospitales / superficie superior plana Suitable for shopping malls, Hospitals / Flat top surface	100	130	70	245	Acabamento Aluminio Mill finish Aluminium	± 20	30 Ton 6,5 Ton

Junta de expansión de suelo incrustado
Flush mounted floor expansion joint profiles



» COR_050 820

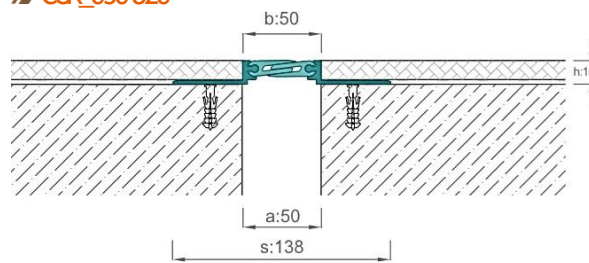

» COR_030 821

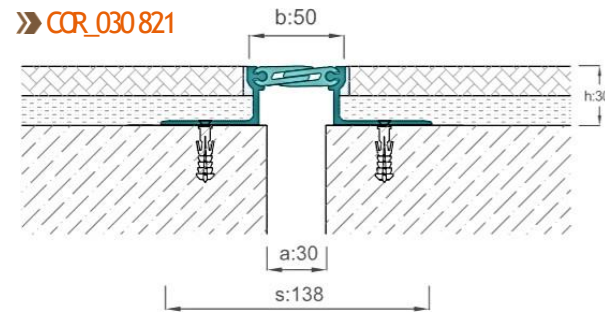

» COR_100 823

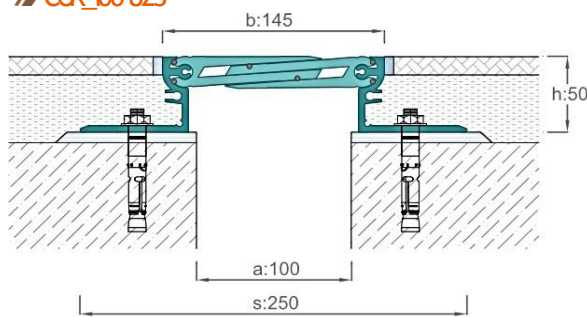

» COR_101 823

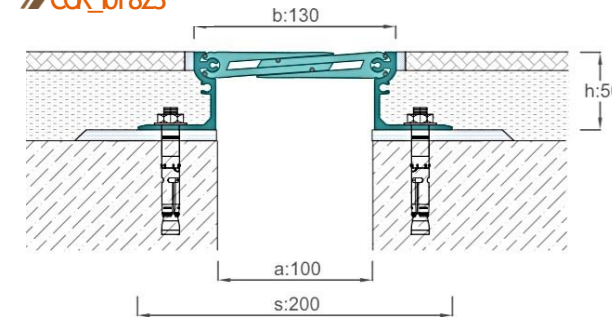

Juntas de suelo pesadas e higiénicas
Heavy duty and hygienic floor profiles

La serie COR 800 tiene capacidad de movimiento tridimensional y es higiénica, resistente a cargas pesadas con diferentes alturas de pie. Adecuado para todo tipo de suelos y duradero en centros comerciales, hospitales, hoteles y estructuras industriales.

COR 800 series have three-dimensional movement capacity and are hygienic, resistant to heavy loads with different footing heights, Suitable for all kinds of flooring types and durable at shopping centers, hospitals, hotels and industrial structures.



REF	DESCRIÇÃO DESCRIPTION	ANCHO CONJUNTO (a) mm JOINT WIDTH	SUPERFICIE VISIBLE (b) mm SURFACE VISIBLE	ALTURA (h) mm PROFILE HEIGHT	ANCHO (s) mm TOTAL WIDTH	SUPERFICIE SURFACE	CAPACIDAD DE MOVIMIENTO MOVEMENT CAPACITY	CAPACIDAD DE CARGA LOAD CAPACITY
COR_050 820	Adecuado para centros comerciales, hospitales / superficie superior plana Suitable for shopping malls, Hospitals / Flat top surface	50	50	15	138	Acabamento Aluminio Mill finish Aluminium	± 5	2,5 Ton
COR_030 821	Adecuado para centros comerciales, hospitales / superficie superior plana Suitable for shopping malls, Hospitals / Flat top surface	30	50	30	138	Acabamento Aluminio Mill finish Aluminium	± 5	9 Ton, 3,5 Ton
COR_100 823	Adecuado para centros comerciales, hospitales / superficie superior plana Suitable for shopping malls, Hospitals / Flat top surface	100	145	24/40/50/60/70	250	Acabamento Aluminio Mill finish Aluminium	± 20	30 Ton, 6,5 Ton
COR_101 823	Adecuado para centros comerciales, hospitales / superficie superior plana Suitable for shopping malls, Hospitals / Flat top surface	100	130	50/60/70/90	200	Acabamento Aluminio Mill finish Aluminium	± 18	9 Ton, 3,5 Ton
COR_150 823	Adecuado para centros comerciales, hospitales / superficie superior plana Suitable for shopping malls, Hospitals / Flat top surface	150	210	65	340	Acabamento Aluminio Mill finish Aluminium	+30/-25	30 Ton, 6,5 Ton
COR_151 823	Adecuado para centros comerciales, hospitales / superficie superior plana Suitable for shopping malls, Hospitals / Flat top surface	150	160	50	290	Acabamento Aluminio Mill finish Aluminium	± 20	9 Ton, 3,5 Ton
COR_200 823	Adecuado para centros comerciales, hospitales / superficie superior plana Suitable for shopping malls, Hospitals / Flat top surface	200	210	65	380	Acabamento Aluminio Mill finish Aluminium	± 30	30 Ton, 6,5 Ton
COR_202 823	Adecuado para centros comerciales, hospitales / superficie superior plana Suitable for shopping malls, Hospitals / Flat top surface	200	208	50	340	Acabamento Aluminio Mill finish Aluminium	± 30	9 Ton, 3,5 Ton
COR_250 823	Adecuado para centros comerciales, hospitales / superficie superior plana Suitable for shopping malls, Hospitals / Flat top surface	250	260	65	430	Acabamento Aluminio Mill finish Aluminium	± 45	30 Ton, 6,5 Ton

Junta de expansión de suelo incrustado
Flush mounted floor expansion joint profiles:



» CCR_150 823

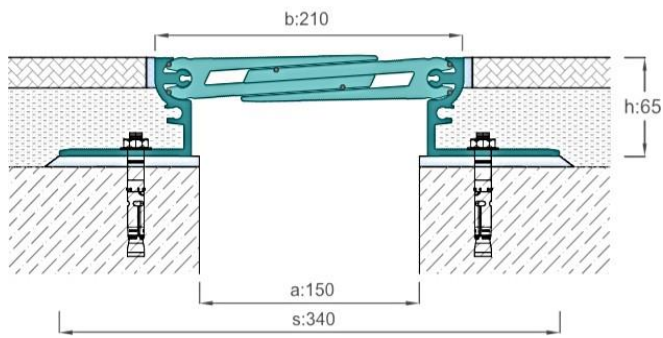

» CCR_150K 823

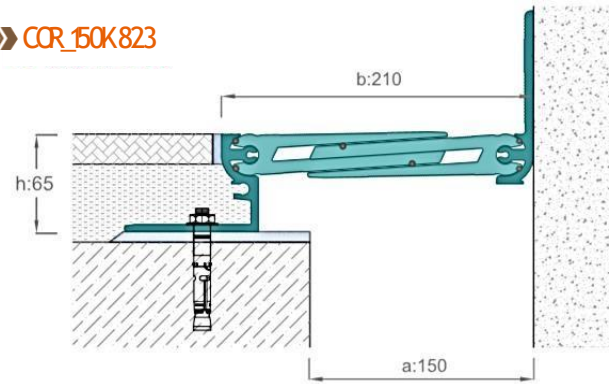

» CCR_151 823

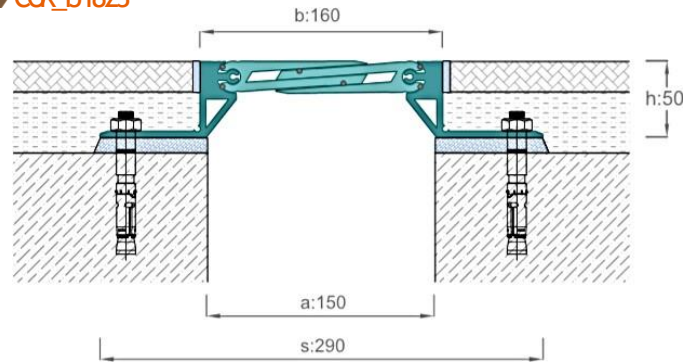

Juntas de suelo
pesadas e higiénicas
Heavy duty and
hygienic floor profiles

» CCR_100 820



» CCR_100 822



» CCR_100 823



» CCR_100 824



» CCR_100 825



» CCR_101 827

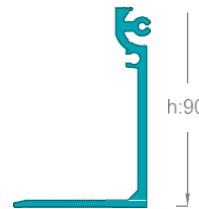

Junta de expansión de suelo incrustado
Flush mounted floor expansion joint profiles



» COR_100 821

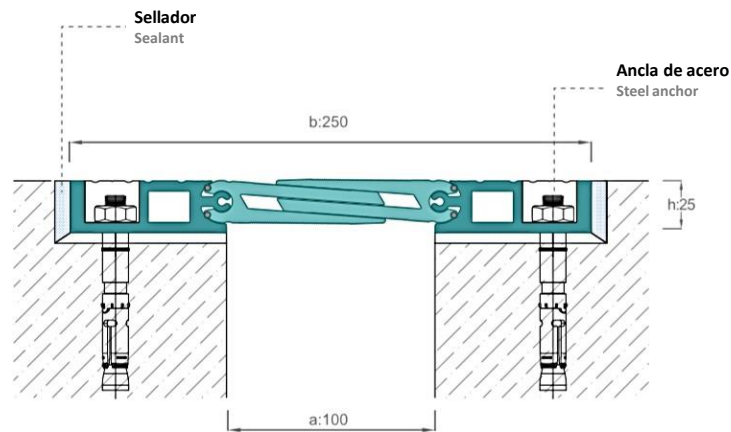

» COR_150 821

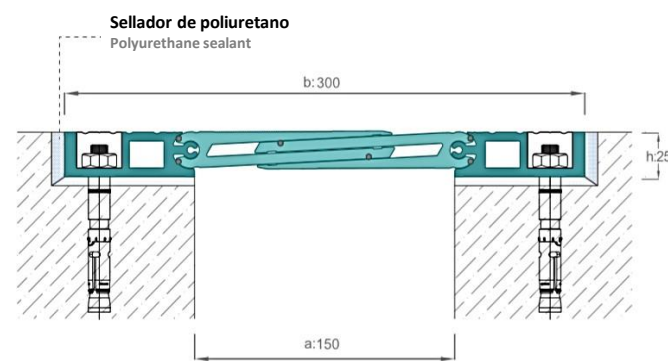

Juntas de suelo pesadas e higiénicas
Heavy duty and hygienic floor profiles

Especial para suelos sin cobertura. Fácilmente aplicable a pequeñas bandas de separación, resistente a cargas pesadas. En los conductores, se requieren dimensiones de holgura de 30 mm x 80 mm para montar estas juntas.

Special for no cover-floors. Easily applicable to the small gap ranges and resistant to heavy loads. At leads, 30mmx80mm gap dimensions are required to assemble these profiles.



REF	DESCRIPCIÓN DESCRIPTION	ANCHO CONJUNTO (a) mm JOINT WIDTH	SUPERFICIE VISIBLE (b) mm SURFACE VISIBLE	ALTURA (h) mm PROFILE HEIGHT	ANCHO (s) mm TOTAL WIDTH	SUPERFICIE SURFACE	CAPACIDAD DE MOVIMIENTO MOVEMENT CAPACITY	CAPACIDAD DE CARGA LOAD CAPACITY
COR_100 821	Adecuado para estructuras industriales y aparcamientos. Suitable for industrial structures and car parks.	100	250	25	250	Acabamento Aluminio Mill Finish Aluminium	± 20	30 Ton 6,5 Ton
COR_150 821	Adecuado para estructuras industriales y aparcamientos. Suitable for industrial structures and car parks.	150	300	25	300	Acabamento Aluminio Mill Finish Aluminium	± 25	30 Ton 6,5 Ton
COR_200 821	Adecuado para estructuras industriales y aparcamientos. Suitable for industrial structures and car parks.	200	350	25	350	Acabamento Aluminio Mill Finish Aluminium	± 25	15 Ton 3,5 Ton

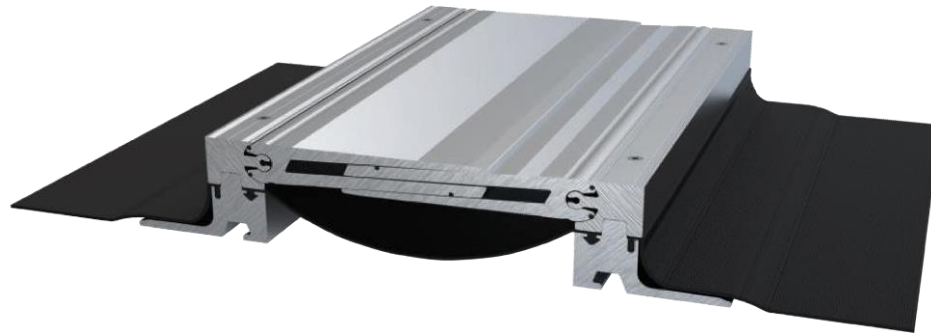

» COR_100 821

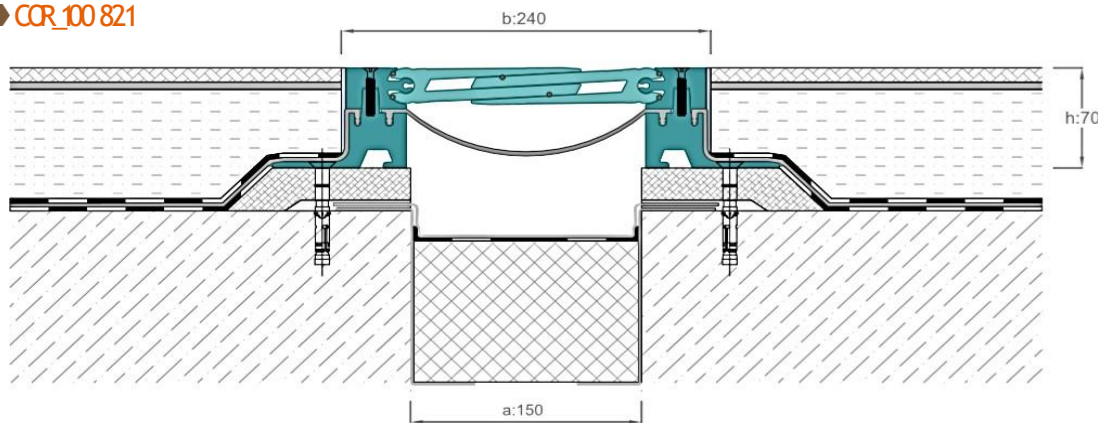

» COR_200 835

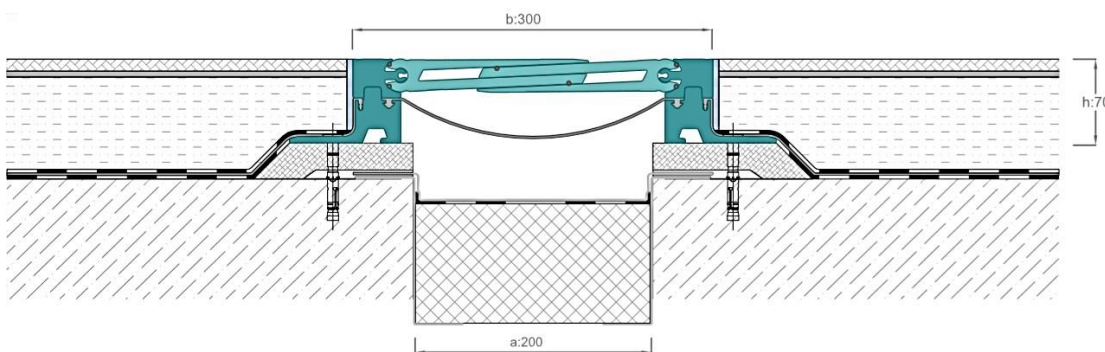

Juntas de suelo
 pesadas e higiénicas
 Heavy duty and
 hygienic floor profiles

La serie COR 835 son juntas de expansión de suelo multipropósitos. El diseño higiénico y las piezas de impermeabilización extraíbles opcionales son resistentes a cargas pesadas. Es preferido en aeropuertos, centros comerciales, hospitales y humedales.

COR 835 series are multi-purpose floor expansion joint profiles. Hygienic design and optional removable waterproofing parts are resistant to heavy loads. It is preferred in airports, shopping malls, hospitals and wet areas.

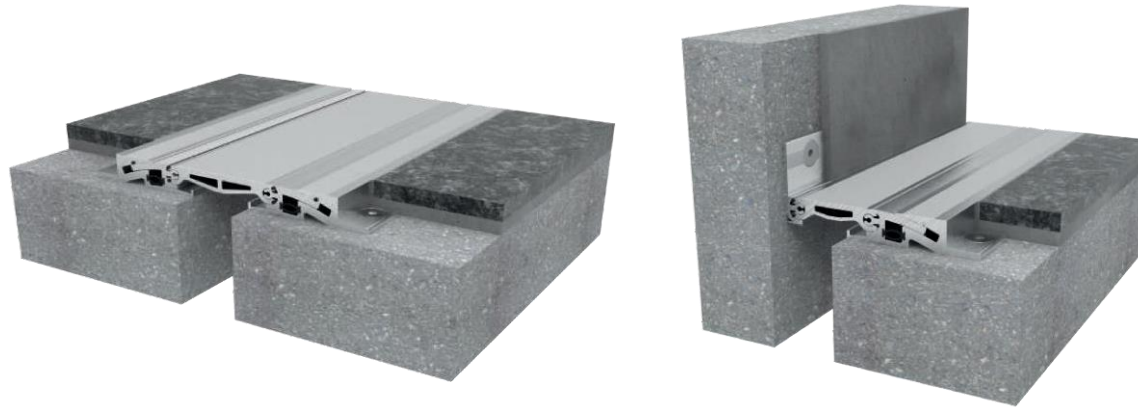

REF	DESCRIPCIÓN DESCRIPTION	ANCHO CONJUNTO (a) mm JOINT WIDTH	SUPERFICIE VISIBLE (b) mm SURFACE VISIBLE	ALTURA (h) mm PROFILE HEIGHT	ANCHO (s) mm TOTAL WIDTH	SUPERFICIE SURFACE	CAPACIDAD DE MOVIMIENTO MOVEMENT CAPACITY	CAPACIDAD DE CARGA LOAD CAPACITY
COR_150 835	Adecuado para estructuras industriales y aparcamientos Suitable for industrial structures and car parks	150	240	70	356	Acabamento Aluminio Mill finish Aluminium	+50/-30	30 Ton 7 Ton
COR_200 835	Adecuado para estructuras industriales y aparcamientos Suitable for industrial structures and car parks	200	300	70	406	Acabamento Aluminio Mill finish Aluminium	+ 50	30 Ton 7 Ton
COR_250 835	Adecuado para estructuras industriales y aparcamientos Suitable for industrial structures and car parks	250	350	70	456	Acabamento Aluminio Mill finish Aluminium	± 50	16 Ton 3,5 Ton

Junta de expansión de suelo incrustado
 Flush mounted floor expansion joint profiles

>> COR_050841

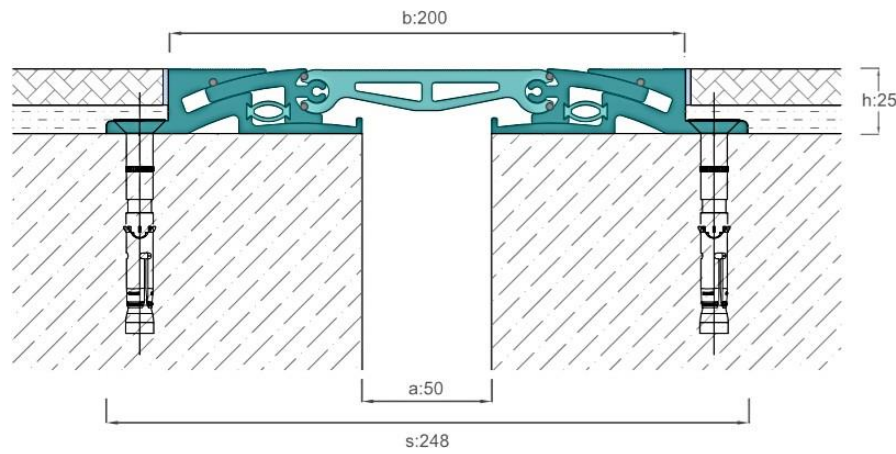

Juntas de suelo pesadas e higiénicas
 Heavy duty and hygienic floor profiles

>> COR_050K841

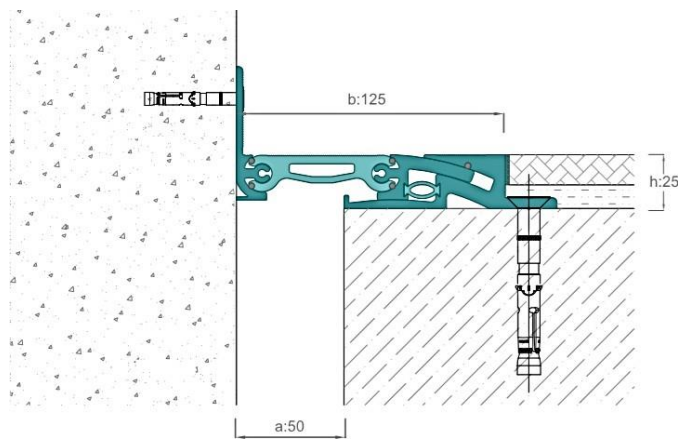

Las juntas de expansión de superficie superior de aluminio son resistentes a cargas pesadas. Móvil en direcciones tridimensionales y superficie antideslizante.
 Fully aluminum top surface expansion joint profiles are resistant to heavy loads. Movable in three dimensional directions and have non-slip surface.

REF	DESCRIÇÃO DESCRIPTION	ANCHO CONJUNTO (a) mm JOINT WIDTH	SUPERFICIE VISIBLE (b) mm SURFACE VISIBLE	ALTURA (h) mm PROFILE HEIGHT	ANCHO (s) mm TOTAL WIDTH	SUPERFICIE SURFACE	CAPACIDAD DE MOVIMIENTO MOVEMENT CAPACITY	CAPACIDAD DE CARGA LOAD CAPACITY
COR_050841	Adecuado para el tráfico de vehículos pesados / superficie superior de aluminio. Suitable for intense vehicle traffic / aluminum top surface.	50	200	25	248	Acabamento Aluminio Mill finish Aluminium	± 20	60 Ton 9 Ton
COR_100841	Adecuado para el tráfico de vehículos pesados / superficie superior de aluminio. Suitable for intense vehicle traffic / aluminum top surface.	100	250	25	298	Acabamento Aluminio Mill finish Aluminium	± 20	60 Ton 9 Ton
COR_150841	Adecuado para el tráfico de vehículos pesados / superficie superior de aluminio. Suitable for intense vehicle traffic / aluminum top surface.	150	300	25	345	Acabamento Aluminio Mill finish Aluminium	± 20	60 Ton 9 Ton



» CCR_100 841

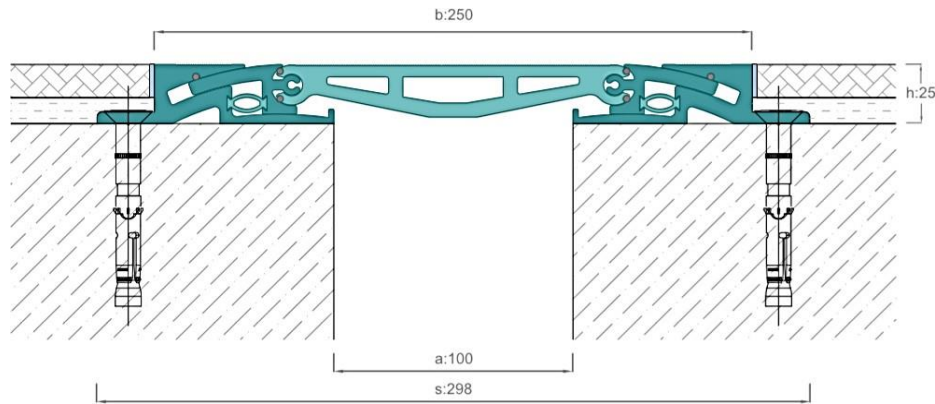

Juntas de suelo
pesadas e higiénicas
Heavy duty and
hygienic floor profiles

» CCR_100K 841

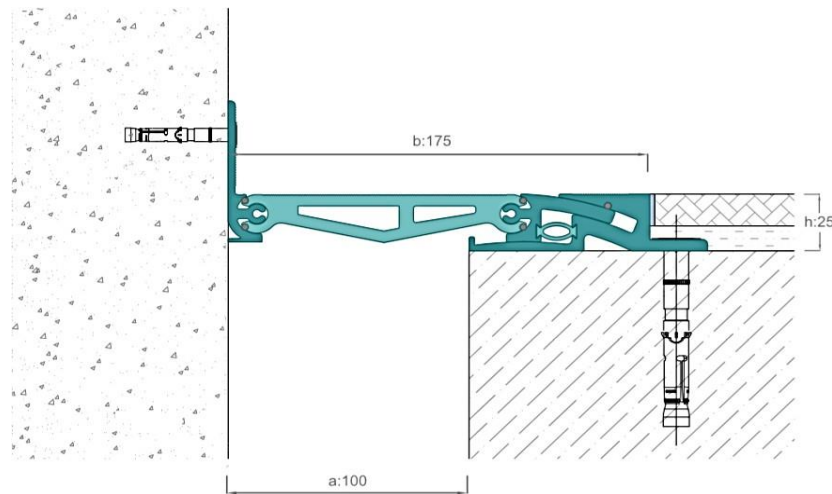

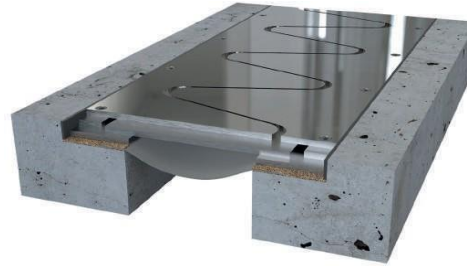

» COR_050 902

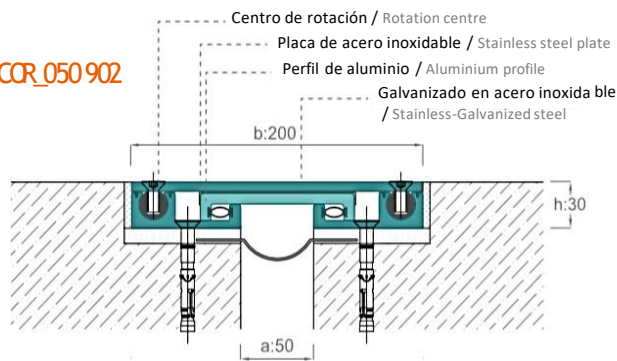

» COR_100 902

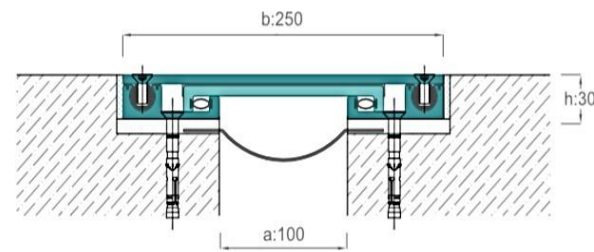

» COR_160 901

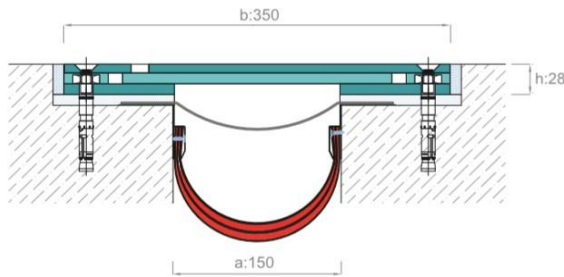

» Aplicación de esquina/Corner application

 pesadas e higiénicas
 Heavy duty and
 hygienic floor profiles

Especialmente diseñado para soportar cargas de carretillas elevadoras y utilizado en estructuras industriales con características de diseño curvadas linealmente y cuerpo de acero. Fabricado en galvanizado por inmersión y tipo de acero. T, + los detalles del sindicato también están disponibles.
 Specially designed to resist forklift loads and used in industrial structures with features of linearly curved design and steel body. Manufactured as dip galvanized and steel type. T, + joining details are also available.

REF	DESCRIPCIÓN DESCRIPTION	ANCHO CONJUNTO (a) mm JOINT WIDTH	SUPERFICIE VISIBLE (b) mm SURFACE VISIBLE	ALTURA (h) mm PROFILE HEIGHT	Ancho (s) mm TOTAL WIDTH	SUPERFICIE SURFACE	CAPACIDAD DE MOVIMIENTO MOVEMENT CAPACITY	CAPACIDAD DE CARGA LOAD CAPACITY
COR_050 902	Fondo de aluminio + superficie superior galvanizada Aluminum bottom part + galvanized top surface	50	200	30	200	Galvanizado Galvanized	± 20	60 Ton 9 Ton
COR_051 902	Fondo de aluminio + superficie superior de acero inoxidable Aluminum bottom part + stainless steel top surface	50	200	30	200	Acero inoxidable Stainless steel	± 20	60 Ton 9 Ton
COR_052 902	Fondo de aluminio + superficie superior de aluminio Aluminum bottom part + aluminum top surface	50	200	30	200	Aluminio Aluminium	± 20	60 Ton 9 Ton
COR_050 901	Fondo de aluminio + superficie superior galvanizada Aluminum bottom part + galvanized top surface	50	200	28	200	Galvanizado Galvanized	± 10	60 Ton 9 Ton
COR_100 902	Fondo de aluminio + superficie superior galvanizada Aluminum bottom part + galvanized top surface	100	250	30	250	Galvanizado Galvanized	± 20	60 Ton 9 Ton
COR_101 902	Fondo de aluminio + superficie superior de acero inoxidable Aluminum bottom part + stainless steel top surface	100	250	30	250	Acero inoxidable Stainless steel	± 20	60 Ton 9 Ton
COR_102 902	Fondo de aluminio + superficie superior de aluminio Aluminum bottom part + aluminum top surface	100	250	30	250	Aluminio Aluminium	± 20	60 Ton 9 Ton
COR_100 901	Fondo de aluminio + superficie superior galvanizada Aluminum bottom part + galvanized top surface	100	300	28	300	Galvanizado Galvanized	± 10	60 Ton 9 Ton
COR_150 902	Fondo de aluminio + superficie superior galvanizada Aluminum bottom part + galvanized top surface	150	300	30	300	Galvanizado Galvanized	± 20	60 Ton 9 Ton
COR_151 902	Fondo de aluminio + superficie superior de acero inoxidable Aluminum bottom part + stainless steel top surface	150	300	30	300	Acero inoxidable Stainless steel	± 20	60 Ton 9 Ton
COR_152 902	Fondo de aluminio + superficie superior de aluminio Aluminum bottom part + aluminum top surface	150	300	30	300	Aluminio Aluminium	± 20	60 Ton 9 Ton
COR_150 901	Fondo de aluminio + superficie superior galvanizada Aluminum bottom part + galvanized top surface	150	350	28	350	Galvanizado Galvanized	± 10	60 Ton 9 Ton
COR_200 901	Fondo de aluminio + superficie superior galvanizada Aluminum bottom part + galvanized top surface	200	400	30	400	Galvanizado Galvanized	± 10	60 Ton 9 Ton

Junta de expansión de suelo de superficie
Surface mounted floor expansion joint profiles



» COR_050753

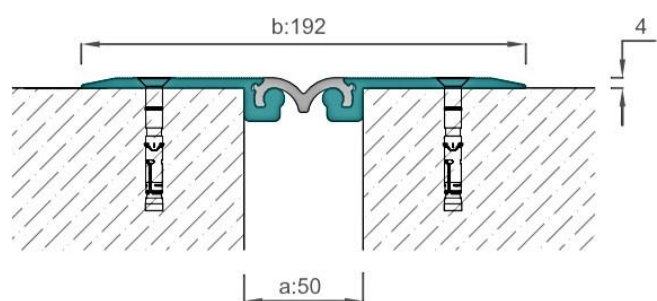

» COR_050K753

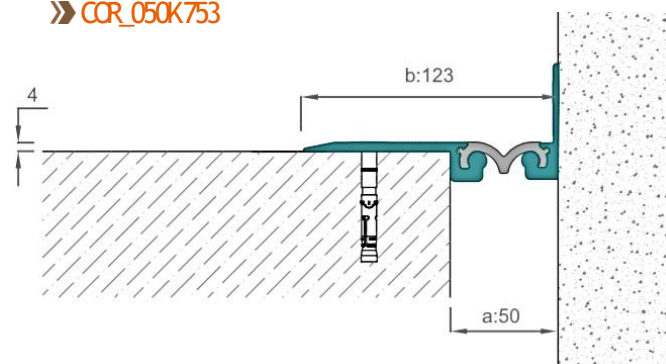

» COR_100773

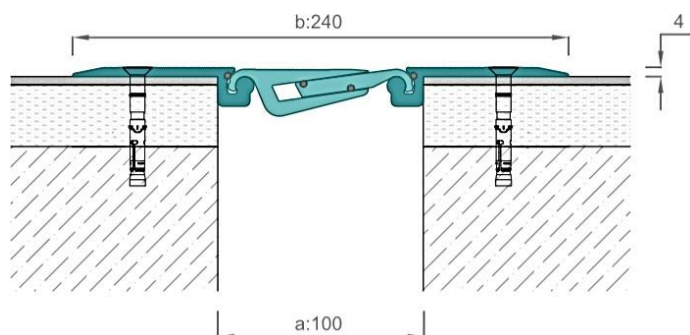

» COR_100K773

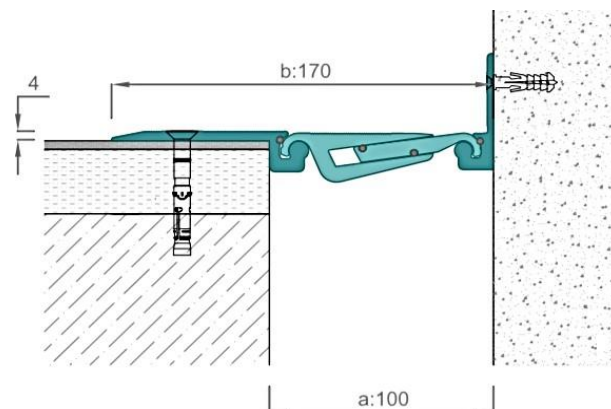

Juntas de suelo pesadas e higiénicas
Heavy duty and hygienic floor profiles

Las juntas de suelo de superficie son resistentes al tráfico de vehículos ligeros. Se puede aplicar en revestimientos de suelos terminados, como suelos de hormigón crudo. Montado en el suelo con anclajes. Acero
Surface mounted floor profiles are resistant to light vehicle traffic. Can be applied on finished floor covers such as gross concrete floors. Assembled to the floor with steel anchors.



REF	DESCRIPCIÓN DESCRIPTION	ANCHO CONJUNTO (a) mm JOINT WIDTH	SUPERFICIE VISIBLE (b) mm SURFACE VISIBLE	ALTURA (h) mm PROFILE HEIGHT	ANCHO (s) mm TOTAL WIDTH	SUPERFICIE SURFACE	CAPACIDAD DE MOVIMIENTO MOVEMENT CAPACITY	CAPACIDAD DE CARGA LOAD CAPACITY
COR_050753	Adecuado para el tráfico de vehículos pesados / superficie superior de aluminio. Suitable for intense vehicle traffic / aluminium top surface.	50	192	14	192	Acabamento Alu + TPE Mill finish Alu + TPE	± 10	9 Ton 5 Ton
COR_080763	Adecuado para el tráfico de vehículos pesados / superficie superior de aluminio. Suitable for intense vehicle traffic / aluminium top surface.	80	220	14	220	Acabamento Aluminio Mill finish Aluminium	± 10	9 Ton 3.5 Ton
COR_100773	Adecuado para el tráfico de vehículos pesados / superficie superior de aluminio. Suitable for intense vehicle traffic / aluminium top surface.	100	240	14	240	Acabamento Aluminio Mill finish Aluminium	± 12	6 Ton 1.5 Ton

Junta de expansión de suelo de superficie
 Surface mounted floor expansion joint profiles

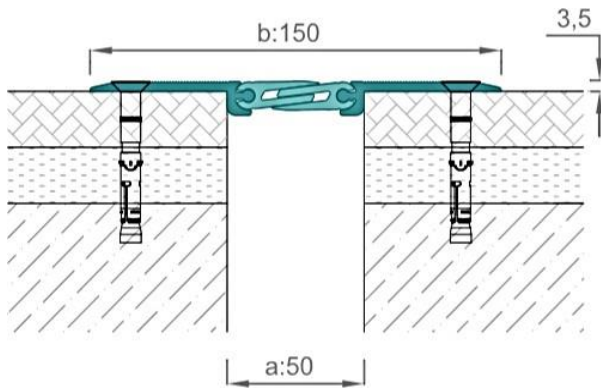

» CCR_050 883

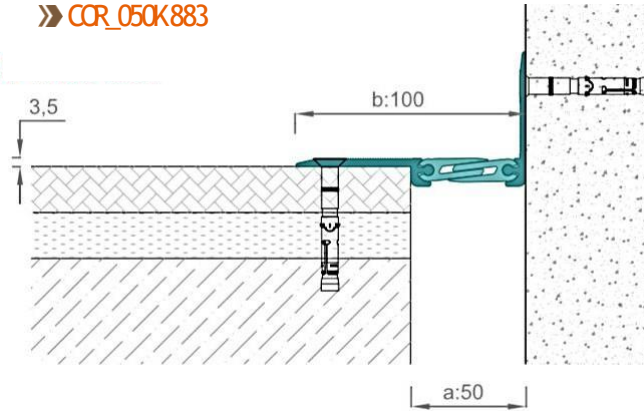

» CCR_050K 883

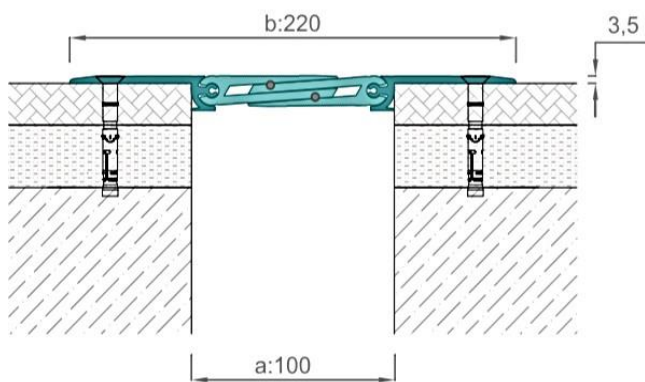

» CCR_100 883



» CCR_100K 883

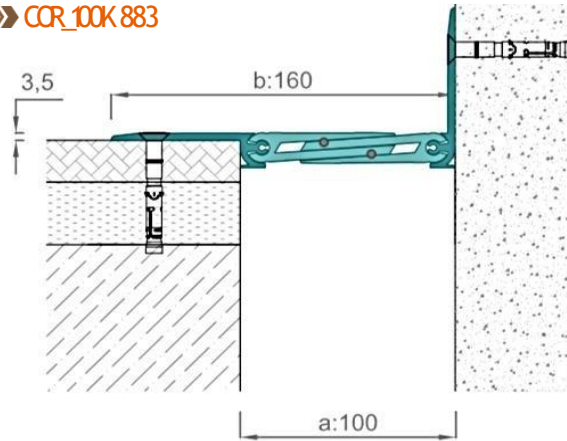

Juntas de suelo
pesadas e higiénicas
Heavy duty and
hygienic floor profiles

Las juntas de suelo de superficie pueden moverse en direcciones tridimensionales.
Surface Mounted floor profiles have the capacity to move in three dimensional directions



REF	DESCRIPCIÓN DESCRIPTION	ANCHO CONJUNTO (a) mm JOINT WIDTH	SUPERFICIE VISIBLE (b) mm SURFACE VISIBLE	ALTURA (h) mm PROFILE HEIGHT	ANCHO (s) mm TOTAL WIDTH	SUPERFICIE SURFACE	CAPACIDAD DE MOVIMIENTO MOVEMENT CAPACITY	CAPACIDAD DE CARGA LOAD CAPACITY
COR_050 883	Adecuado para aparcamientos/agujeros aéreos. Suitable for car parks/countersunk holes	50	150	10	150	Acabamento Aluminio. Mill finish Aluminium	± 5	1.5 Ton
COR_100 883	Adecuado para aparcamientos/agujeros aéreos. Suitable for car parks/countersunk holes	100	220	13	220	Acabamento Aluminio. Mill finish Aluminium	± 12	6 Ton, 1.5 Ton
COR_150 883	Adecuado para aparcamientos/agujeros aéreos. Suitable for car parks/countersunk holes	150	300	20	300	Acabamento Aluminio. Mill finish Aluminium	± 25	3.5 Ton, 1.5 Ton
COR_200 883	Adecuado para aparcamientos/agujeros aéreos. Suitable for car parks/countersunk holes	200	350	26	350	Acabamento Aluminio. Mill finish Aluminium	+40/-15	3.5 Ton, 2 Ton

Juntas de expansión sísmica
Seismic expansion joint profiles

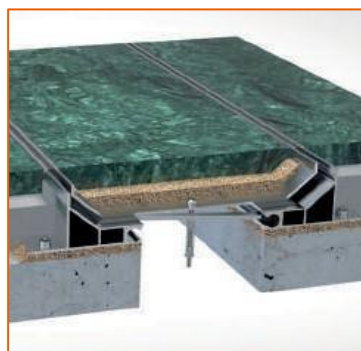
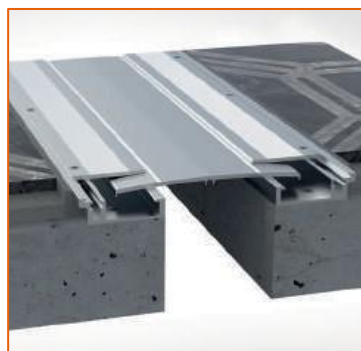
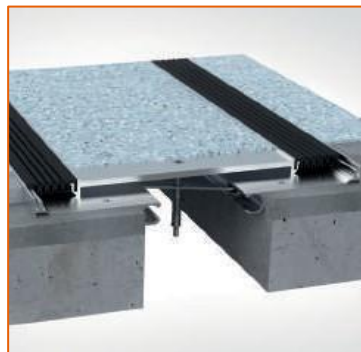

Incrustación de juntas sísmicas de dilatación
 Flush mounted seismic floor joint profiles

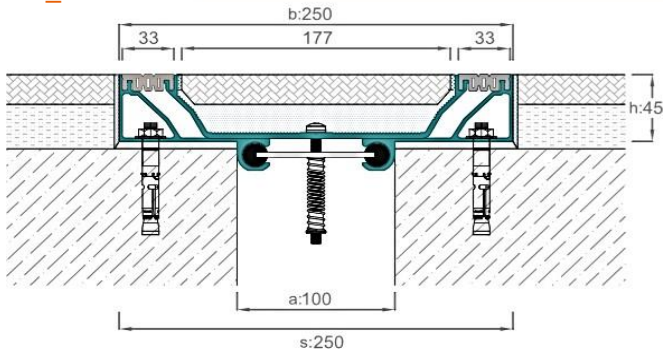

» COR_100 802

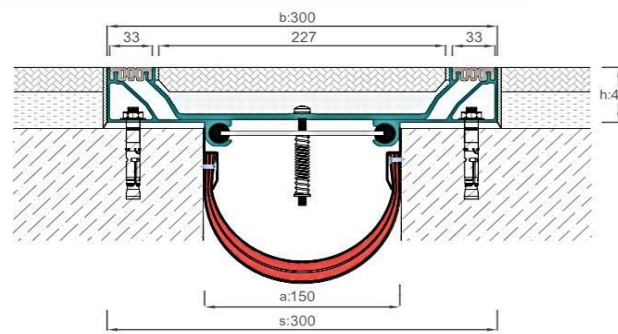

» COR_150 802

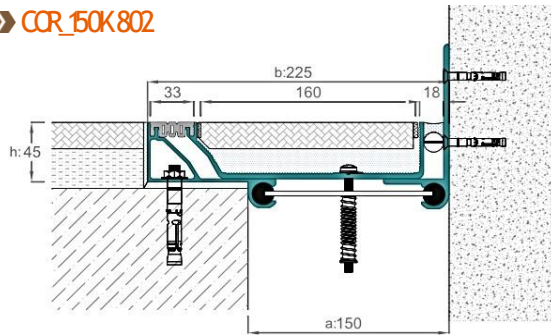

» COR_150K 802

 Juntas sísmicas de suelos,
 paredes y techos
 Seismic floor, wall, Ceiling
 profiles

Adecuado para revestimientos de suelo de bajo nivel como cubiertas de PVC y epoxi. La alta capacidad móvil y las juntas de sellado TPE grandes se pueden usar para pisos.

Suitable for low levelled floor covers such as PVC and epoxy covers. High movable capacity and large TPE gasketed profiles are usable for floors.



REF	DESCRIPCIÓN DESCRIPTION	ANCHO CONJUNTO (a) mm JOINT WIDTH	SUPERFICIE VISIBLE (b) mm SURFACE VISIBLE	ALTURA (h) mm PROFILE HEIGHT	ANCHO (s) mm TOTAL WIDTH	SUPERFICIE SURFACE	CAPACIDAD DE MOVIMIENTO MOVEMENT CAPACITY	CAPACIDAD DE CARGA LOAD CAPACITY
COR_100 802	Junta de suelo sísmica con junta de expansión Seismic floor expansion joint profile with gasket	100	250	45	250	Acabamento Aluminio Mill finish Aluminium	± 50	+ Maq. Limpieza Cleaning machine
COR_150 802	Junta de suelo sísmica con junta de expansión Seismic floor expansion joint profile with gasket	150	300	45	300	Acabamento Aluminio Mill finish Aluminium	± 70	+ Maq. Limpieza Cleaning machine
COR_200 802	Junta de suelo sísmica con junta de expansión Seismic floor expansion joint profile with gasket	200	400	45	400	Acabamento Aluminio Mill finish Aluminium	+100/-80	+ Maq. Limpieza Cleaning machine
COR_250 802	Junta de suelo sísmica con junta de expansión Seismic floor expansion joint profile with gasket	250	480	60	480	Acabamento Aluminio Mill finish Aluminium	± 125	+ Maq. Limpieza Cleaning machine
COR_300 802	Junta de suelo sísmica con junta de expansión Seismic floor expansion joint profile with gasket	300	600	60	600	Acabamento Aluminio Mill finish Aluminium	± 150	+ Maq. Limpieza Cleaning machine
COR_350 802	Junta de suelo sísmica con junta de expansión Seismic floor expansion joint profile with gasket	350	650	60	650	Acabamento Aluminio Mill finish Aluminium	± 175	+ Maq. Limpieza Cleaning machine
COR_400 802	Junta de suelo sísmica con junta de expansión Seismic floor expansion joint profile with gasket	400	700	60	700	Acabamento Aluminio Mill finish Aluminium	+175/-200	+ Maq. Limpieza Cleaning machine
COR_450 802	Junta de suelo sísmica con junta de expansión Seismic floor expansion joint profile with gasket	450	750	60	750	Acabamento Aluminio Mill finish Aluminium	+175/-225	+ Maq. Limpieza Cleaning machine
COR_500 802	Junta de suelo sísmica con junta de expansión Seismic floor expansion joint profile with gasket	500	800	60	800	Acabamento Aluminio Mill finish Aluminium	+175/-250	+ Maq. Limpieza Cleaning machine



» COR 100_803

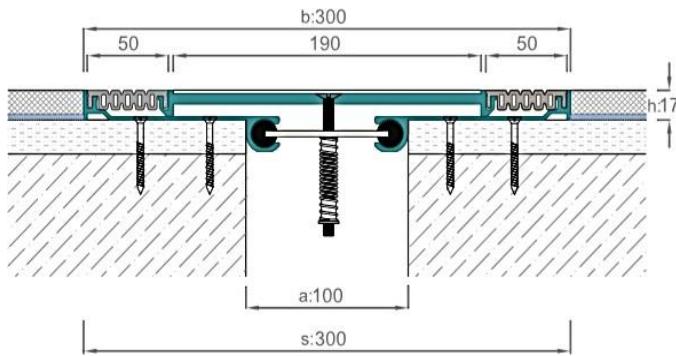

» COR 150_803

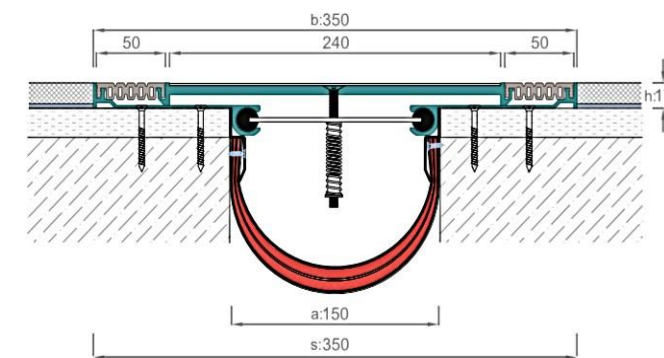
 Juntas sísmicas de suelos,
 paredes y techos
 Seismic floor, wall, ceiling
 profiles

» COR 200_803

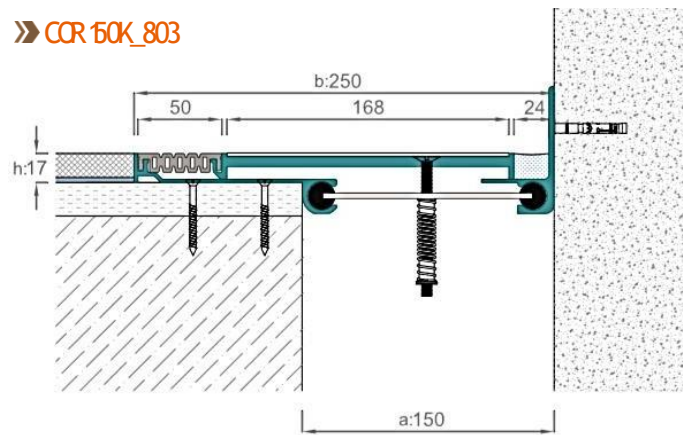

Adecuado para revestimientos de suelo de bajo nivel como cubiertas de PVC y epoxy. La alta capacidad móvil y los grandes perfiles de sellado TPE se pueden usar para pisos.
 Suitable for low levelled floor covers such as PVC and epoxy covers. High movable capacity and large TPE gasketed profiles are usable for floors.



REF	DESCRIPCIÓN DESCRIPTION	ANCHO CONJUNTO (a) mm JOINT WIDTH	SUPERFICIE VISIVEL (b) mm SURFACE VISIBLE	ALTURA (h) mm PROFILE HEIGHT	ANCHO (s) mm TOTAL WIDTH	SUPERFICIE SURFACE	CAPACIDAD DE MOVIMIENTO MOVEMENT CAPACITY	CAPACIDAD DE CARGA LOAD CAPACITY
COR_100803	Adecuado para pisos de PVC / Con junta Suitable for PVC floor covers / gasketed	100	300	17	300	Acabado Alu + TPE + Cubierta Mill finish Alu + TPE + Cover	± 50	+ Maq. Limpieza Cleaning machine
COR_150803	Adecuado para pisos de PVC / Con junta Suitable for PVC floor covers / gasketed	150	350	17	350	Acabado Alu + TPE + Cubierta Mill finish Alu + TPE + Cover	± 75	+ Maq. Limpieza Cleaning machine
COR_200803	Adecuado para pisos de PVC / Con junta Suitable for PVC floor covers / gasketed	200	400	17	400	Acabado Alu + TPE + Cubierta Mill finish Alu + TPE + Cover	± 100	+ Maq. Limpieza Cleaning machine

Juntas de expansión sísmica, incrustaciones para suelos
Flush mounted seismic floor joint profiles



Perfil en U de acero inoxidable
Stainless steel U Profile

» COR 100_804

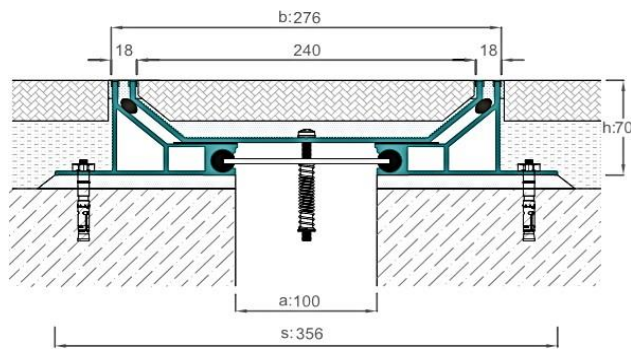

» COR 150_804

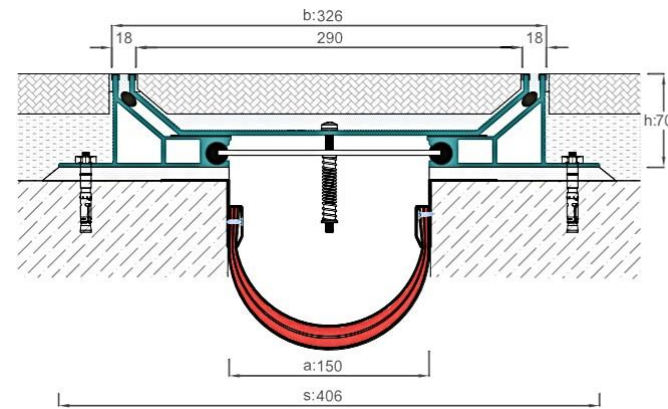

» COR 150K_804

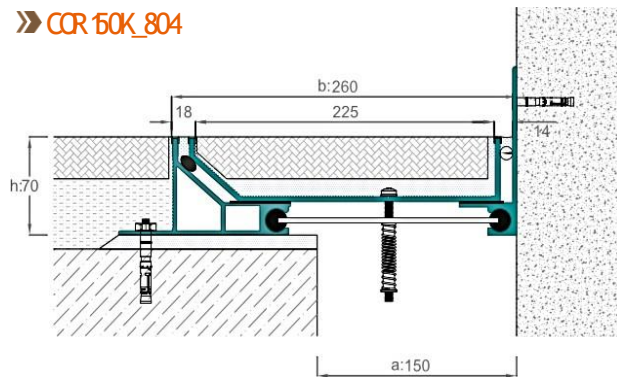

Juntas sísmicas de suelos,
paredes y techos
Seismic floor, wall, Ceiling
profiles



Diseñado para aplicarse en grandes espacios y proporcionar pequeñas partes visibles. Aún así, la serie COR 803 tiene menos capacidad de movimiento en comparación con otras juntas sísmicas, pero el diseño decorativo todavía lo hace especial.
Designed to apply on large gaps and provide small visible portions. Even though, COR 803 series has less movement capacity compared to other seismic profiles, the decorative design still makes it special to be preferred.

REF	DESCRIPCIÓN DESCRIPTION	ANCHO CONJUNTO (a) mm JOINT WIDTH	SUPERFICIE VISIBLE (b) mm SURFACE VISIBLE	ALTURA (h) mm PROFILE HEIGHT	ANCHO (s) mm TOTAL WIDTH	SUPERFICIE SURFACE	CAPACIDAD DE MOVIMIENTO MOVEMENT CAPACITY	CAPACIDAD DE CARGA LOAD CAPACITY
COR_100_804	Superficie superior en acero inoxidable + aplicación de sellador Stainless steel top surface + Sealant application	100	276	70	356	Acero Inoxidável + Sellador + Tapa Stainless steel + Sealant + Cover	± 50	+ Maq. Limpeza Cleaning machine
COR_150_804	Superficie superior en acero inoxidable + aplicación de sellador Stainless steel top surface + Sealant application	150	326	70	406	Acero Inoxidável + Sellador + Tapa Stainless steel + Sealant + Cover	± 75	+ Maq. Limpeza Cleaning machine
COR_200_804	Superficie superior en acero inoxidable + aplicación de sellador Stainless steel top surface + Sealant application	200	376	70	456	Acero Inoxidável + Sellador + Tapa Stainless steel + Sealant + Cover	± 75	+ Maq. Limpeza Cleaning machine
COR_250_804	Superficie superior en acero inoxidable + aplicación de sellador Stainless steel top surface + Sealant application	250	426	70	506	Acero Inoxidável + Sellador + Tapa Stainless steel + Sealant + Cover	± 75	+ Maq. Limpeza Cleaning machine
COR_300_804	Superficie superior en acero inoxidable + aplicación de sellador Stainless steel top surface + Sealant application	300	590	70	671	Acero Inoxidável + Sellador + Tapa Stainless steel + Sealant + Cover	± 75	+ Maq. Limpeza Cleaning machine

Juntas de expansión sísmica, incrustaciones para suelos
 Flush mounted seismic floor joint profiles

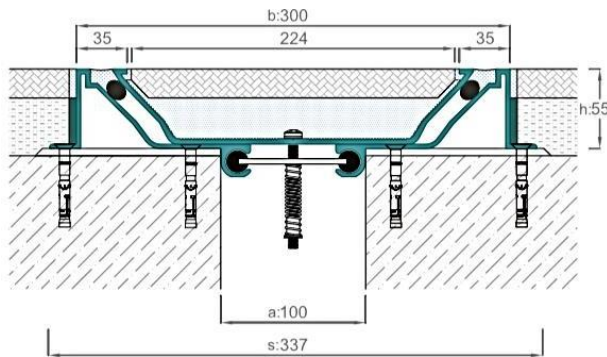

>> COR 100_806

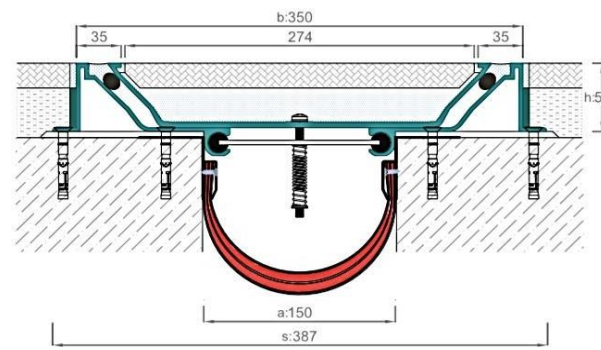

>> COR 150_806

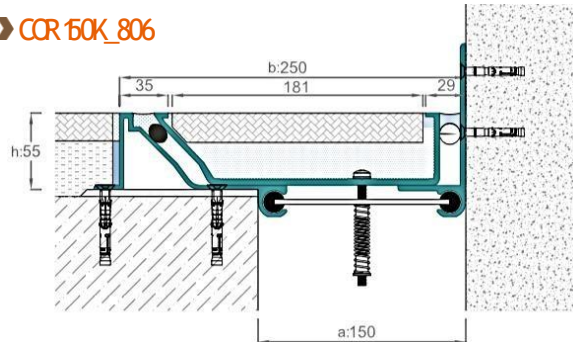

>> COR 200_806

 Juntas sísmicas de suelos,
 paredes y techos
 Seismic floor, wall, ceiling
 profiles

La serie COR 806 son opciones económicas y alternativas, las juntas de expansión sísmica del suelo para una alta capacidad de movimiento. Son aplicables a grandes huecos con superficie visible muy estrecha. Adecuado para todo tipo de suelos. La masa epoxi utilizada en la parte central para evitar grietas o daños puede ocurrir en la cubierta del suelo.

COR 806 series are economic and alternative options to floor seismic expansion joint profiles to have high movement capacity. They are applicable to large gaps with very narrow visible surface. Suitable for all flooring types. Epoxy filler used in middle part to avoid any cracks or damages could occur to floor cover.



REF	DESCRIPCIÓN DESCRIPTION	ANCHO CONJUNTO (a) mm JOINT WIDTH	SUPERFICIE VISIBLE (b) mm SURFACE VISIBLE	ALTURA (h) mm PROFILE HEIGHT	ANCHO (s) mm TOTAL WIDTH	SUPERFICIE SURFACE	CAPACIDAD DE MOVIMIENTO MOVEMENT CAPACITY	CAPACIDAD DE CARGA LOAD CAPACITY
COR_100_806	Junta sísmica aplicada al sellador Sealant applied seismic floor profile	100	300	55	337	Acabado Alu + Sellador + Revestimiento de suelo Mill finish Alu + Sealant + Floor cover	± 50	+ Maq. Limpieza Cleaning machine
COR_150_806	Junta sísmica aplicada al sellador Sealant applied seismic floor profile	150	350	55	387	Acabado Alu + Sellador + Revestimiento de suelo Mill finish Alu + Sealant + Floor cover	± 75	+ Maq. Limpieza Cleaning machine
COR_200_806	Junta sísmica aplicada al sellador Sealant applied seismic floor profile	200	400	55	437	Acabado Alu + Sellador + Revestimiento de suelo Mill finish Alu + Sealant + Floor cover	± 100	+ Maq. Limpieza Cleaning machine
COR_250_806	Junta sísmica aplicada al sellador Sealant applied seismic floor profile	250	550	65	587	Acabado Alu + Sellador + Revestimiento de suelo Mill finish Alu + Sealant + Floor cover	± 125	+ Maq. Limpieza Cleaning machine
COR_300_806	Junta sísmica aplicada al sellador Sealant applied seismic floor profile	300	600	65	637	Acabado Alu + Sellador + Revestimiento de suelo Mill finish Alu + Sealant + Floor cover	± 150	+ Maq. Limpieza Cleaning machine
COR_350_806	Junta sísmica aplicada al sellador Sealant applied seismic floor profile	350	650	65	687	Acabado Alu + Sellador + Revestimiento de suelo Mill finish Alu + Sealant + Floor cover	± 175	+ Maq. Limpieza Cleaning machine
COR_400_806	Junta sísmica aplicada al sellador Sealant applied seismic floor profile	400	700	65	737	Acabado Alu + Sellador + Revestimiento de suelo Mill finish Alu + Sealant + Floor cover	± 200	+ Maq. Limpieza Cleaning machine
COR_450_806	Junta sísmica aplicada al sellador Sealant applied seismic floor profile	450	750	65	787	Acabado Alu + Sellador + Revestimiento de suelo Mill finish Alu + Sealant + Floor cover	± 200	+ Maq. Limpieza Cleaning machine
COR_500_806	Junta sísmica aplicada al sellador Sealant applied seismic floor profile	500	800	65	837	Acabado Alu + Sellador + Revestimiento de suelo Mill finish Alu + Sealant + Floor cover	± 200	+ Maq. Limpieza Cleaning machine

Juntas de expansión sísmica, incrustaciones para suelos
 Flush mounted seismic floor joint profiles

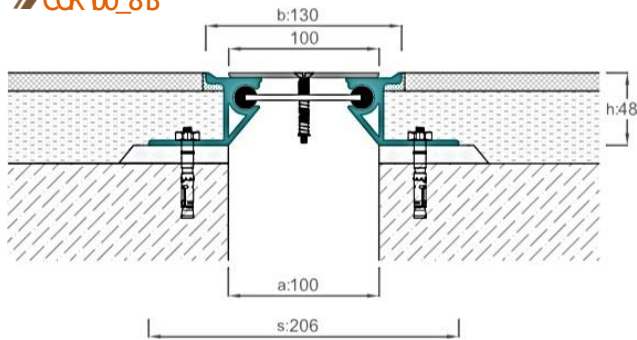

» COR 100_813

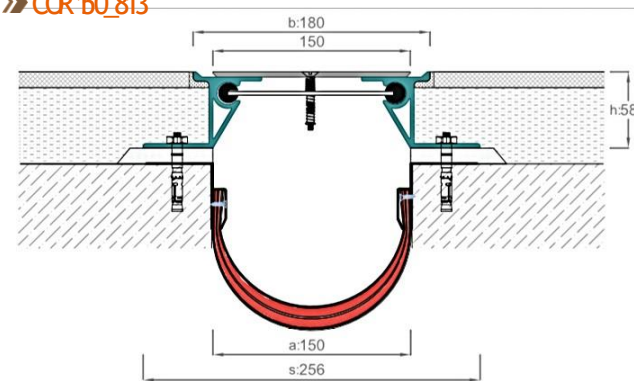

» COR 150_813

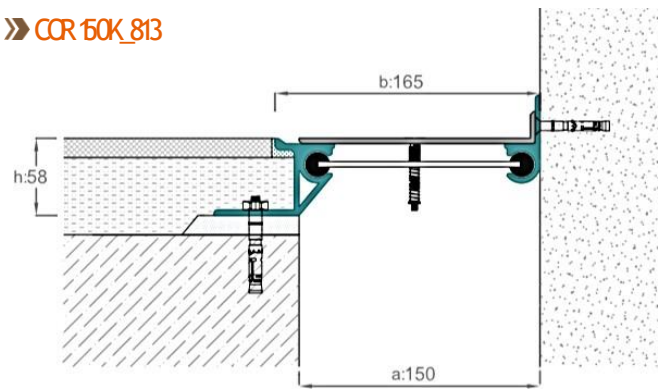

» COR 160K_813

 Juntas sísmicas de suelos,
 paredes y techos
 Seismic floor, wall, ceiling
 profiles

Las juntas higiénicas y decorativas de la serie COR 813 se componen del perfil inferior de aluminio y la placa superior de acero inoxidable. Especialmente utilizado en estaciones de metro, centros comerciales y hospitales.

Hygienic and decorative COR 813 series profiles are composed of aluminum bottom profile and stainless-steel top plate. Especially used in metro stations, shopping centers and hospitals.



REF	DESCRIPCIÓN DESCRIPTION	ANCHO CONJUNTO (a) mm JOINT WIDTH	SUPERFICIE VISIBLE (b) mm SURFACE VISIBLE	ALTURA (h) mm PROFILE HEIGHT	ANCHO (s) mm TOTAL WIDTH	SUPERFICIE SURFACE	CAPACIDAD DE MOVIMIENTO MOVEMENT CAPACITY	CAPACIDAD DE CARGA LOAD CAPACITY
COR_100_813	Superficie superior en acero inoxidable + junta sísmica del suelo Stainless steel top surface + Seismic floor profile	100	130	48	206	Acabado Alu + Acero Inoxidable Mill finish Alu + Stainless steel	+40/-50	3,5 Ton
COR_150_813	Superficie superior en acero inoxidable + junta sísmica del suelo Stainless steel top surface + Seismic floor profile	150	180	58	256	Acabado Alu + Acero Inoxidable Mill finish Alu + Stainless steel	+60/-60	3,5 Ton
COR_200_813	Superficie superior en acero inoxidable + junta sísmica del suelo Stainless steel top surface + Seismic floor profile	200	230	58	306	Acabado Alu + Acero Inoxidable Mill finish Alu + Stainless steel	+60/-100	3,5 Ton
COR_250_813	Superficie superior en acero inoxidable + junta sísmica del suelo Stainless steel top surface + Seismic floor profile	250	280	58	356	Acabado Alu + Acero Inoxidable Mill finish Alu + Stainless steel	+60/-125	+ Maq. Limpieza Cleaning machine
COR_300_813	Superficie superior en acero inoxidable + junta sísmica del suelo Stainless steel top surface + Seismic floor profile	300	330	58	406	Acabado Alu + Acero Inoxidable Mill finish Alu + Stainless steel	+60/-150	+ Maq. Limpieza Cleaning machine

Juntas de expansión sísmica, incrustaciones para suelos
 Flush mounted seismic floor joint profiles

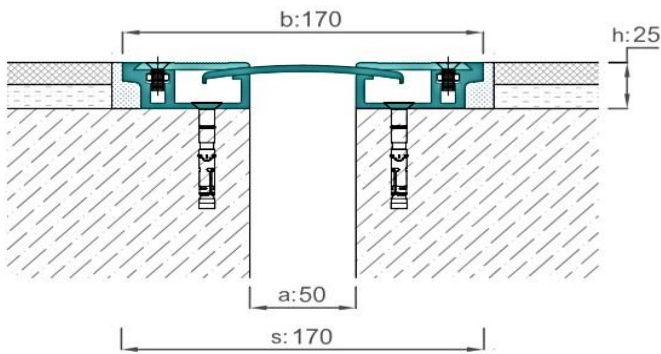

» COR050_851

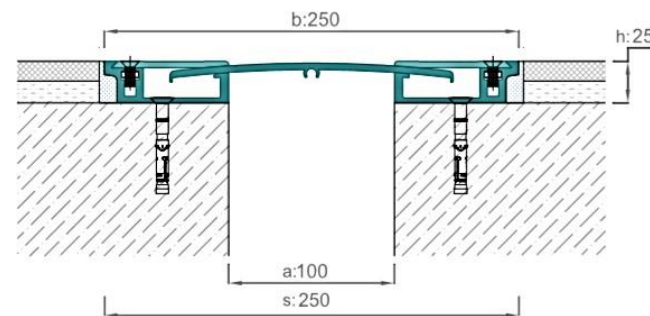

» COR100_851

 Juntas sísmicas de suelos,
 paredes y techos
 Seismic floor, wall, Ceiling
 profiles

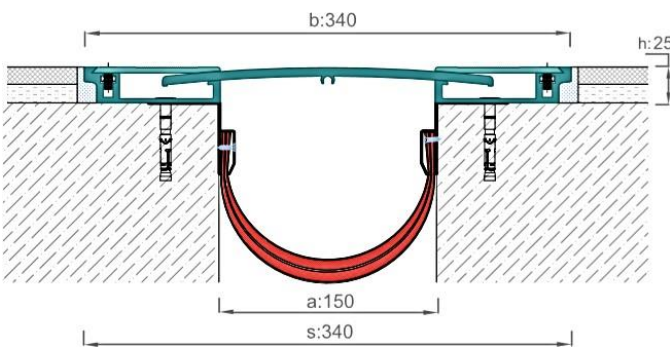
» COR150_851



» COR100K_851

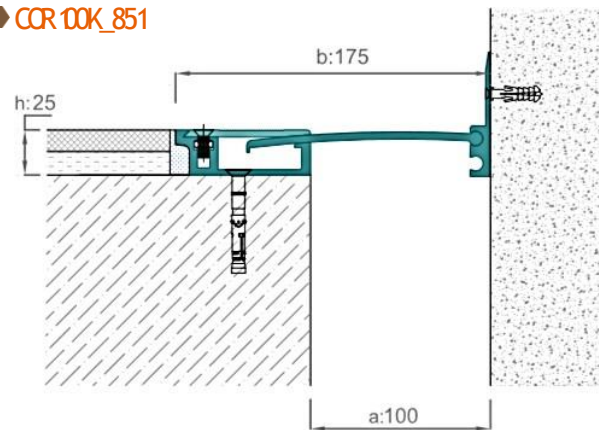

Las juntas de expansión de mecha sísmica tienen características de alta capacidad de movimiento y resistentes a cargas pesadas con una superficie superior totalmente en aluminio.

Seismic floor expansion joint profiles have the features of high movement capacity and resistant to heavy loads with completely aluminum top surface.



REF	DESCRIPCIÓN DESCRIPTION	ANCHO CONJUNTO (a) mm JOINT WIDTH	SUPERFICIE VISIBLE (b) mm SURFACE VISIBLE	ALTURA (h) mm PROFILE HEIGHT	ANCHO (s) mm TOTAL WIDTH	SUPERFICIE SURFACE	CAPACIDAD DE MOVIMIENTO MOVEMENT CAPACITY	CAPACIDAD DE CARGA LOAD CAPACITY
COR_050851	Junta de suelo sísmica con superficie de aluminio. Aluminum top surfaced seismic floor profile	50	170	25	170	Acabamento Aluminio. Mill finish Aluminum	± 25	3,5 Ton
COR_100851	Junta de suelo sísmica con superficie de aluminio. Aluminum top surfaced seismic floor profile	100	250	25	250	Acabamento Aluminio. Mill finish Aluminum	+50/-50	2,5 Ton
COR_101851	Junta de suelo sísmica con superficie de aluminio. Aluminum top surfaced seismic floor profile	100	290	25	290	Acabamento Aluminio. Mill finish Aluminum	± 60	2,5 Ton
COR_125851	Junta de suelo sísmica con superficie de aluminio. Aluminum top surfaced seismic floor profile	125	330	25	330	Acabamento Aluminio. Mill finish Aluminum	± 60	2,5 Ton
COR_150851	Junta de suelo sísmica con superficie de aluminio. Aluminum top surfaced seismic floor profile	150	340	25	340	Acabamento Aluminio. Mill finish Aluminum	± 60	2,5 Ton
COR_200851	Junta de suelo sísmica con superficie de aluminio. Aluminum top surfaced seismic floor profile	200	390	25	390	Acabamento Aluminio. Mill finish Aluminum	± 60	1,5 Ton

Juntas de expansión sísmica, incrustaciones para suelos
Flush mounted seismic floor joint profiles



» COR 100_932

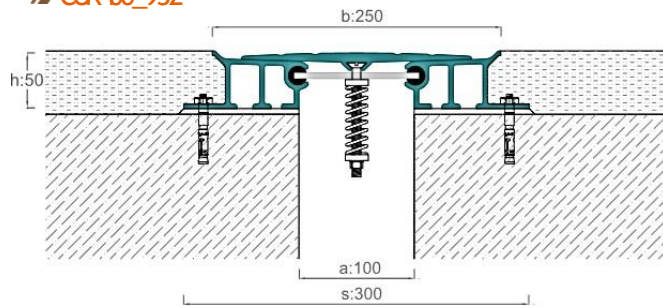

» COR 150_932

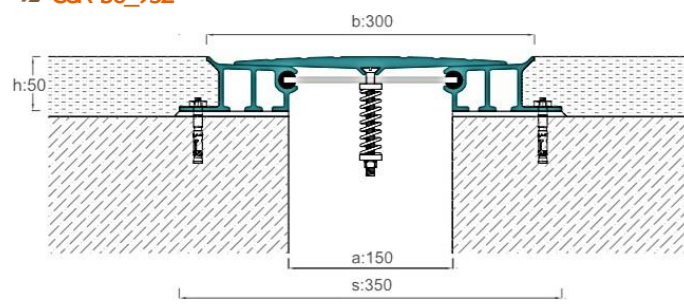

» COR 100K_932

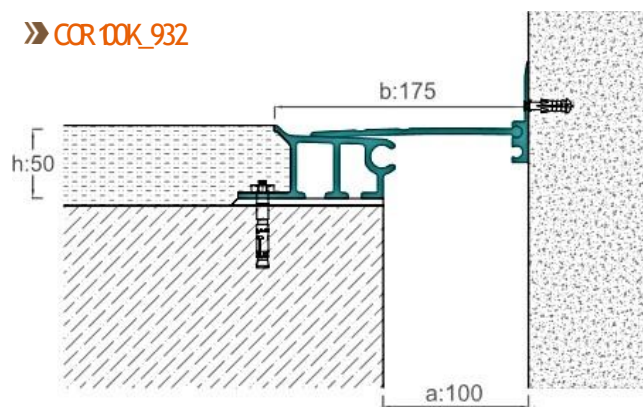

» COR 150K_932

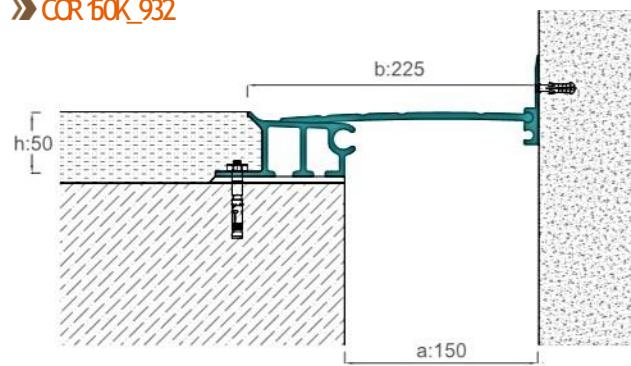

Juntas sísmicas de suelos,
paredes y techos
Seismic floor, wall, Ceiling
profiles

La serie COR 932 se compone de una gran superficie superior de aluminio y es capaz de moverse en direcciones tridimensionales.

COR 932 series are composed of large Aluminum top surface and have the capacity to move in 3 dimensional directions.

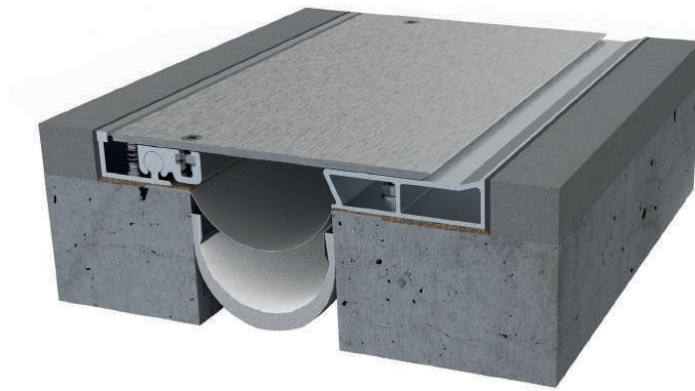

REF	DESCRIPCIÓN DESCRIPTION	ANCHO CONJUNTO (a) mm JOINT WIDTH	SUPERFICIE VISIBLE (b) mm SURFACE VISIBLE	ALTURA (h) mm PROFILE HEIGHT	ANCHO (s) mm TOTAL WIDTH	SUPERFICIE SURFACE	CAPACIDAD DE MOVIMIENTO MOVEMENT CAPACITY	CAPACIDAD DE CARGA LOAD CAPACITY
COR_100_932	Juntas sísmicas de alta capacidad de carga High load capacity seismic profiles	100	250	50	300	Acabamento Aluminio Mill finish Aluminum	± 50	15 To
COR_150_932	Juntas sísmicas de alta capacidad de carga High load capacity seismic profiles	150	300	50	350	Acabamento Aluminio Mill finish Aluminum	± 75	15 To
COR_200_932	Juntas sísmicas de alta capacidad de carga High load capacity seismic profiles	200	350	50	400	Acabamento Aluminio Mill finish Aluminum	+ 100	15 To

Juntas de expansión sísmica, incrustaciones para suelos
 Flush mounted seismic floor joint profiles

» COR_60_931

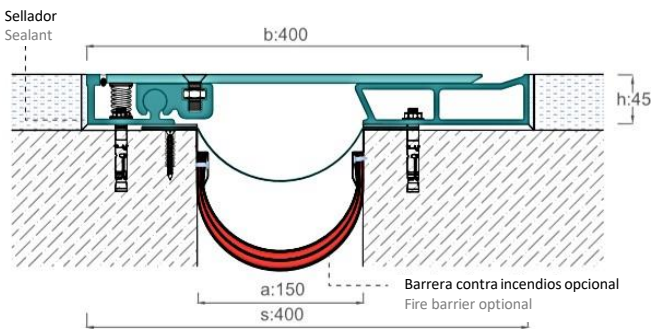

» COR_200_931

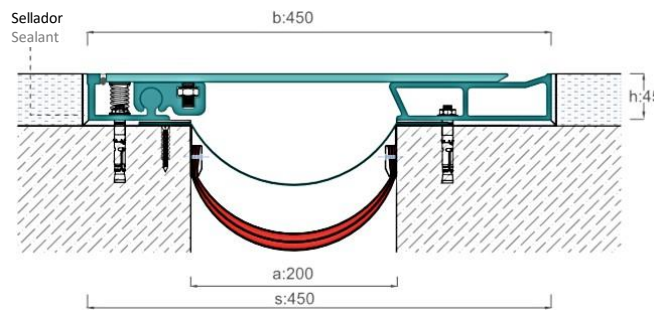
 Juntas sísmicas de suelos,
 paredes y techos
 Seismic floor, wall, ceiling
 profiles

» COR_60K_931

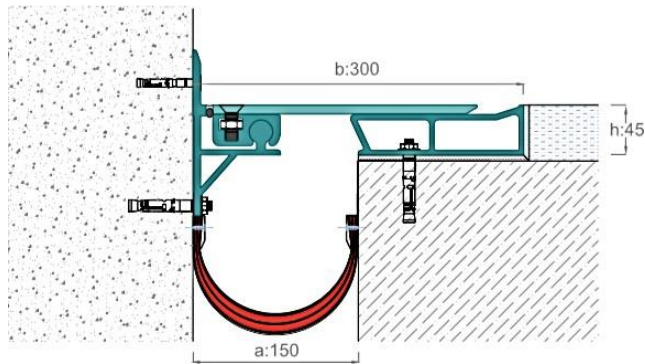

» COR_200K_931

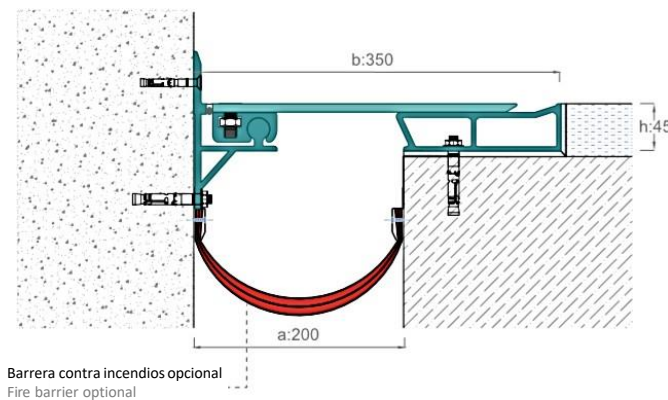

Las juntas de suelo empotradas están articuladas en un lado y tienen opciones alternativas de superficie superior hechas de acero galvanizado y aluminio.

Flush mounted floor profiles are one sided articulated and have alternative top surface options made of galvanized steel and aluminum.

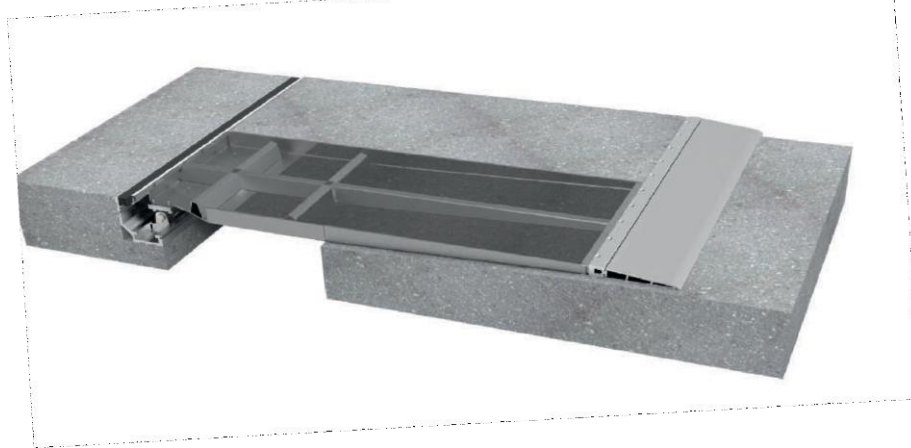

REF	DESCRIPCIÓN DESCRIPTION	ANCHO CONJUNTO (a) mm JOINT WIDTH	SUPERFICIE VISIBLE (b) mm SURFACE VISIBLE	ALTURA (h) mm PROFILE HEIGHT	ANCHO (s) mm TOTAL WIDTH	SUPERFICIE SURFACE	CAPACIDAD DE MOVIMIENTO MOVEMENT CAPACITY	CAPACIDAD DE CARGA LOAD CAPACITY
COR_050_931	Adecuado para estructuras industriales y aparcamientos Suitable for industrial structures and car parks	50	300	45	300	Acabamento Aluminio Mill finish Aluminum	± 25	30 Ton 6,5 Ton
COR_100_931	Adecuado para estructuras industriales y aparcamientos Suitable for industrial structures and car parks	100	350	45	350	Acabamento Aluminio Mill finish Aluminum	± 50	30 Ton 6,5 Ton
COR_150_931	Adecuado para estructuras industriales y aparcamientos Suitable for industrial structures and car parks	150	400	45	400	Acabamento Aluminio Mill finish Aluminum	± 75	30 Ton 6,5 Ton
COR_200_931	Adecuado para estructuras industriales y aparcamientos Suitable for industrial structures and car parks	200	450	45	450	Acabamento Aluminio Mill finish Aluminum	± 100	15 Ton 3,5 Ton
COR_250_931	Adecuado para estructuras industriales y aparcamientos Suitable for industrial structures and car parks	250	550	45	550	Acabado Alu + Acero Galvanizado Mill finish Alu + Galvanized steel	± 100	15 Ton 3,5 Ton
COR_300_931	Adecuado para estructuras industriales y aparcamientos Suitable for industrial structures and car parks	300	600	45	600	Acabado Alu + Acero Galvanizado Mill finish Alu + Galvanized steel	± 100	15 Ton 3,5 Ton

Juntas de dilatação de pavimento sísmico de embutir
 Flush mounted seismic floor joint profiles

>> COR500_961

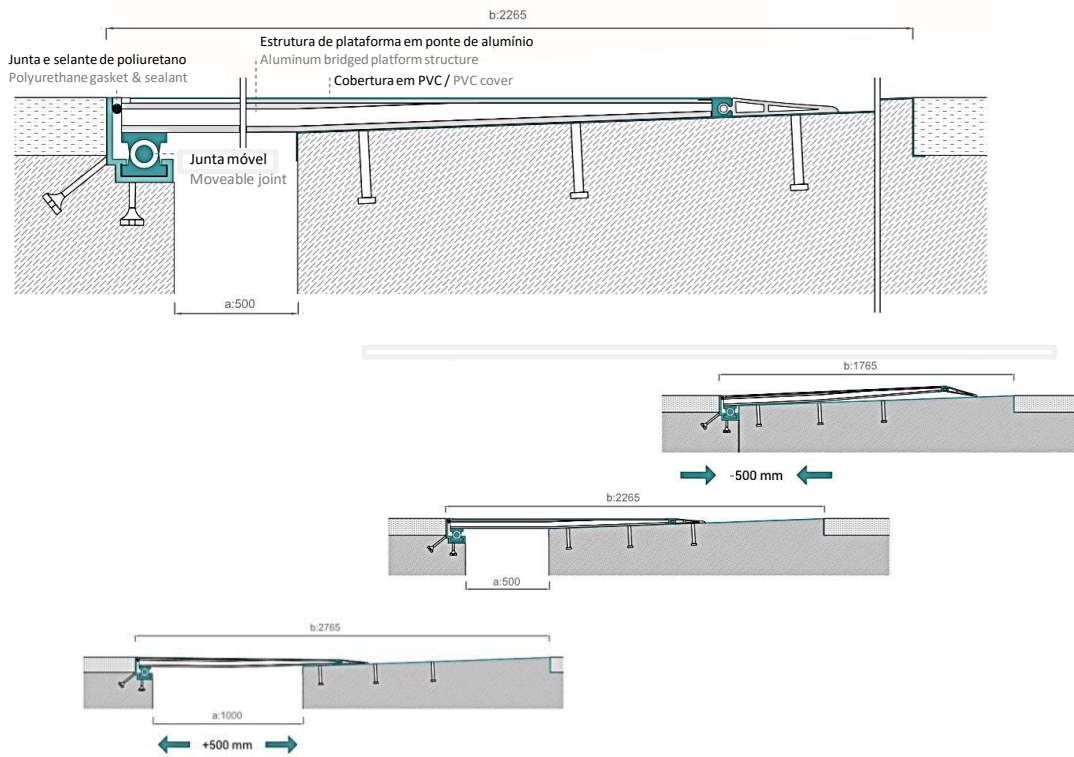
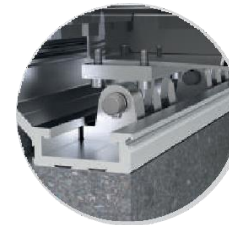
 Juntas sísmicas de suelos,
 paredes y techos
 Seismic floor, wall, ceiling
 profiles

La junta de expansión con bisagras está diseñada para grandes distancias con alta capacidad de movimiento. Regularmente se pueden observar en edificios con aislamiento sísmico. Adecuado para vehículos, rampas y aparcamientos.

Jointed expansion joint profiles are designed for large gaps with high movement capacity. Can often be seen in seismic isolated buildings. Suitable for vehicles, ramps and car parks.

REF	DESCRIPCIÓN DESCRIPTION	ANCHO CONJUNTO (a) mm JOINT WIDTH	SUPERFICIE VISIBLE (b) mm SURFACE VISIBLE	ALTURA (h) mm PROFILE HEIGHT	ANCHO (s) mm TOTAL WIDTH	SUPERFICIE SURFACE	CAPACIDAD DE MOVIMIENTO MOVEMENT CAPACITY	CAPACIDAD DE CARGA LOAD CAPACITY
COR_400961	Alta capacidad de manipulación para juntas grandes High moving capacity for large gaps	400	2065	65	2065	Aluminio + Acero galvanizado + PVC Aluminum + Galvanized steel + PVC	± 400	9 Ton
COR_500961	Alta capacidad de manipulación para juntas grandes High moving capacity for large gaps	500	2265	65	2265	Aluminio + Acero galvanizado + PVC Aluminum + Galvanized steel + PVC	± 500	9 Ton
COR_600961	Alta capacidad de manipulación para juntas grandes High moving capacity for large gaps	600	2465	65	2465	Aluminio + Acero galvanizado + PVC Aluminum + Galvanized steel + PVC	± 600	9 Ton
COR_700961	Alta capacidad de manipulación para juntas grandes High moving capacity for large gaps	700	2665	65	2665	Aluminio + Acero galvanizado + PVC Aluminum + Galvanized steel + PVC	± 700	9 Ton
COR_400971	Alta capacidad de manipulación para juntas grandes High moving capacity for large gaps	400	1274	65	1274	Aluminio + Acero galvanizado + PVC Aluminum + Galvanized steel + PVC	± 400	+ Tráf. Camilla Stretcher traf.
COR_500971	Alta capacidad de manipulación para juntas grandes High moving capacity for large gaps	500	1474	65	1474	Aluminio + Acero galvanizado + PVC Aluminum + Galvanized steel + PVC	± 500	+ Tráf. Camilla Stretcher traf.
COR_600971	Alta capacidad de manipulación para juntas grandes High moving capacity for large gaps	600	1674	65	1674	Aluminio + Acero galvanizado + PVC Aluminum + Galvanized steel + PVC	± 600	+ Tráf. Camilla Stretcher traf.
COR_700971	Alta capacidad de manipulación para juntas grandes High moving capacity for large gaps	700	1874	65	1874	Aluminio + Acero galvanizado + PVC Aluminum + Galvanized steel + PVC	± 700	+ Tráf. Camilla Stretcher traf.
COR_750971	Alta capacidad de manipulación para juntas grandes High moving capacity for large gaps	750	1924	65	1924	Aluminio + Acero galvanizado + PVC Aluminum + Galvanized steel + PVC	± 300	+ Tráf. Camilla Stretcher traf.

Juntas de dilatación de pavimento sísmico de embutir
Flush mounted seismic floor joint profiles



» COR 750_971

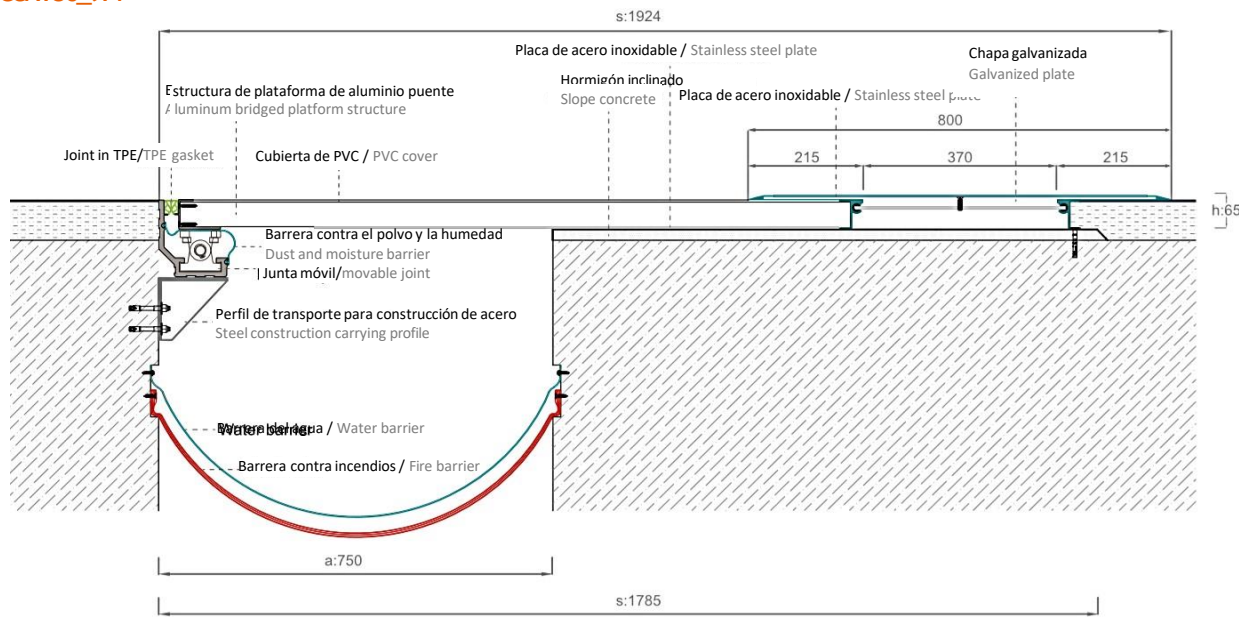

Juntas sísmicas de suelos,
paredes y techos
Seismic floor, wall, ceiling
profiles

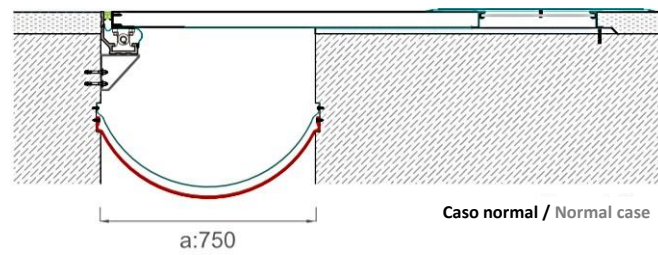
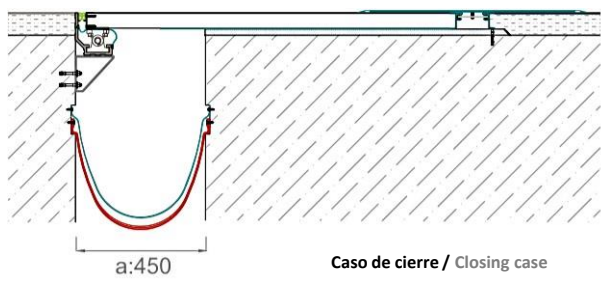

← -300 mm →

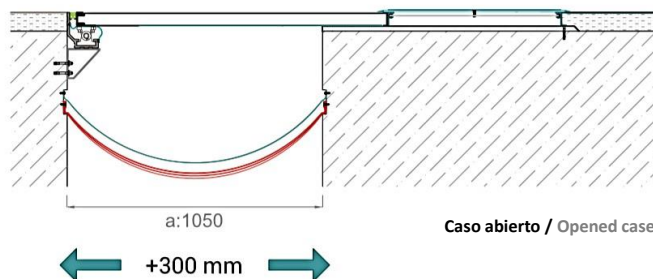

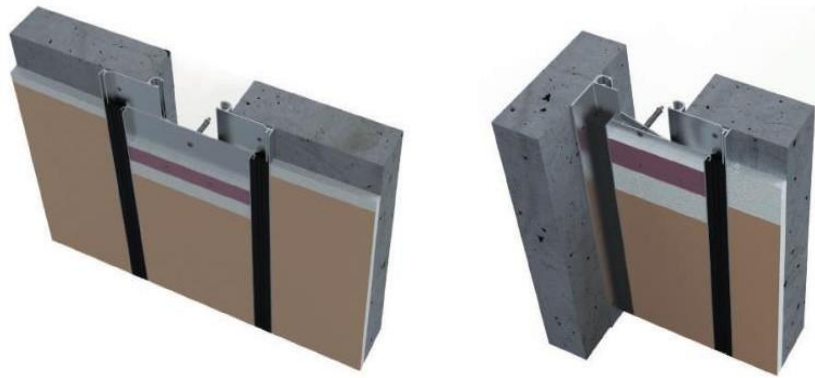
Juntas sísmicas incorporadas para montaje en pared y techo
 Flush mounted seismic wall and ceiling joint profiles

»» COR 100_232

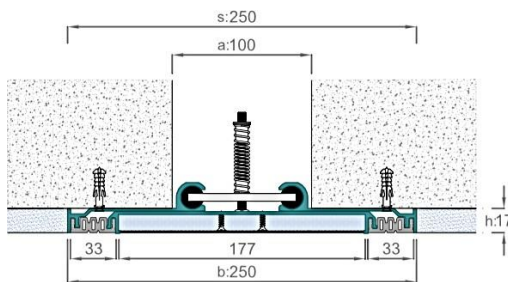

»» COR 150_232

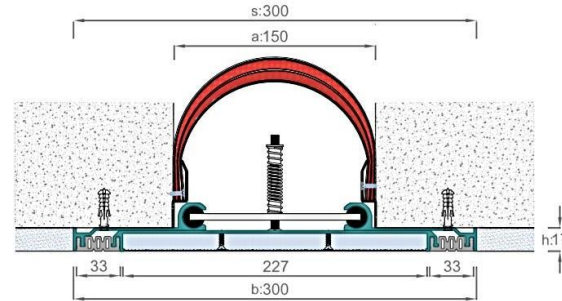

»» COR 160K_232

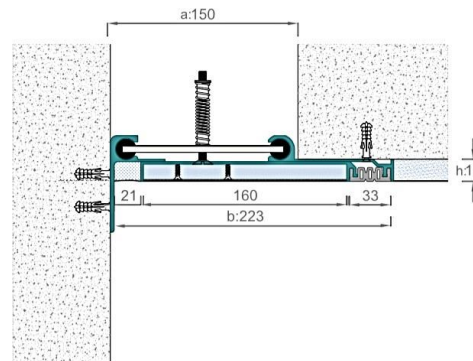
 Juntas sísmicas de suelos,
 paredes y techos
 Seismic floor, wall, ceiling
 profiles

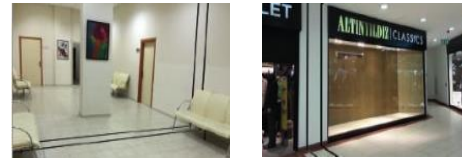
 COLOR 232 son las soluciones de pared y techo de la serie COR 802 de juntas de expansión sísmica.
 COR 232 are the wall and ceiling solutions of COR 802 seismic expansion joint series.

REF	DESCRIPCIÓN DESCRIPTION	ANCHO CONJUNTO (a) mm JOINT WIDTH	SUPERFICIE VISIBLE (b) mm SURFACE VISIBLE	ALTURA PERFIL (h) mm PROFILE HEIGHT	ANCHO TOTAL (s) mm TOTAL WIDTH	SUPERFICIE SURFACE	CAPACIDAD DE MOVIMIENTO MOVEMENT CAPACITY
COR_100_232	Adecuado para solado, yeso, etc/sello. Suitable with screed, dry wall and etc / gasketed	100	250	17	250	Acabado Alu + TPE + cubierta Mill finish ALU + TPE + Cover	± 50
COR_150_232	Adecuado para solado, yeso, etc/sello. Suitable with screed, dry wall and etc / gasketed	150	300	17	300	Acabado Alu + TPE + cubierta Mill finish ALU + TPE + Cover	± 70
COR_200_232	Adecuado para solado, yeso, etc/sello. Suitable with screed, dry wall and etc / gasketed	200	400	20	400	Acabado Alu + TPE + cubierta Mill finish ALU + TPE + Cover	+100/-80
COR_250_232	Adecuado para solado, yeso, etc/sello. Suitable with screed, dry wall and etc / gasketed	250	450	20	450	Acabado Alu + TPE + cubierta Mill finish ALU + TPE + Cover	+125/-80
COR_300_232	Adecuado para solado, yeso, etc/sello. Suitable with screed, dry wall and etc / gasketed	300	600	20	600	Acabado Alu + TPE + cubierta Mill finish ALU + TPE + Cover	± 150
COR_350_212	Adecuado para solado, yeso, etc/sello. Suitable with screed, dry wall and etc / gasketed	350	650	20	650	Acabado Alu + TPE + cubierta Mill finish ALU + TPE + Cover	± 175
COR_400_232	Adecuado para solado, yeso, etc/sello. Suitable with screed, dry wall and etc / gasketed	400	700	20	700	Acabado Alu + TPE + cubierta Mill finish ALU + TPE + Cover	+175/-200
COR_450_232	Adecuado para solado, yeso, etc/sello. Suitable with screed, dry wall and etc / gasketed	450	750	20	750	Acabado Alu + TPE + cubierta Mill finish ALU + TPE + Cover	+175/-225
COR_500_232	Adecuado para solado, yeso, etc/sello. Suitable with screed, dry wall and etc / gasketed	500	800	20	800	Acabado Alu + TPE + cubierta Mill finish ALU + TPE + Cover	± 25

Juntas sísmicas incorporadas para montaje en pared y techo
Flush mounted seismic wall and ceiling joint profiles

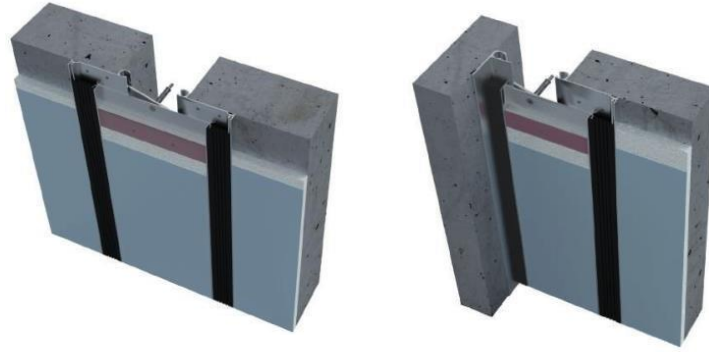

» COR 100_233

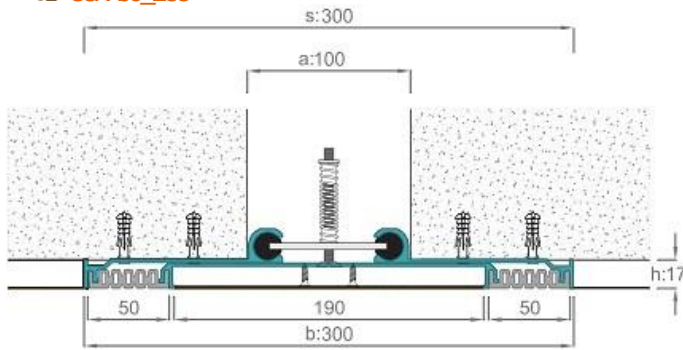

» COR 150_233

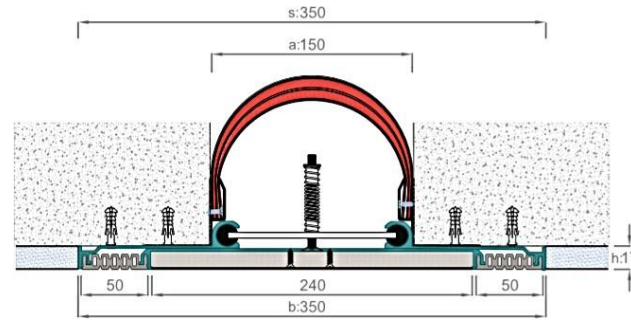

» COR 150K_233

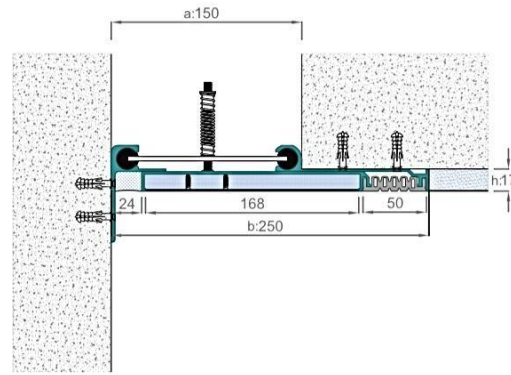

Juntas sísmicas de suelos,
paredes y techos
Seismic floor, wall, ceiling
profiles

Las juntas de pared y techo COR 233 son aplicables a proyectos en los que se han utilizado juntas de suelo sísmico COR 803.

COR 233 wall and ceiling series are applicable to the projects where COR 803 seismic floor profiles have been used.



REF	DESCRIPCIÓN DESCRIPTION	ANCHO CONJUNTO (a) mm JOINT WIDTH	SUPERFICIE VISIBLE (b) mm SURFACE VISIBLE	ALTURA PERFIL (h) mm PROFILE HEIGHT	ANCHO TOTAL (s) mm TOTAL WIDTH	SUPERFICIE SURFACE	CAPACIDAD DE MOVIMIENTO MOVEMENT CAPACITY
COR_100_233	Adecuado para solado, yeso, etc/sello. Suitable with screed, dry wall and etc / gasketed.	100	300	17	300	Acabado Alu + TPE + cubierta. Mill finish ALU + TPE + Cover.	± 50
COR_150_233	Adecuado para solado, yeso, etc/sello. Suitable with screed, dry wall and etc / gasketed.	150	350	17	350	Acabado Alu + TPE + cubierta. Mill finish ALU + TPE + Cover.	± 75
COR_200_233	Adecuado para solado, yeso, etc/sello. Suitable with screed, dry wall and etc / gasketed.	200	400	20	400	Acabado Alu + TPE + cubierta. Mill finish ALU + TPE + Cover.	± 100
COR_250_233	Adecuado para solado, yeso, etc/sello. Suitable with screed, dry wall and etc / gasketed.	250	450	20	450	Acabado Alu + TPE + cubierta. Mill finish ALU + TPE + Cover.	± 125
COR_300_233	Adecuado para solado, yeso, etc/sello. Suitable with screed, dry wall and etc / gasketed.	300	500	20	500	Acabado Alu + TPE + cubierta. Mill finish ALU + TPE + Cover.	± 125

Juntas sísmicas incorporadas para montaje en pared y techo
Flush mounted seismic wall and ceiling joint profiles.



» COR 100_234

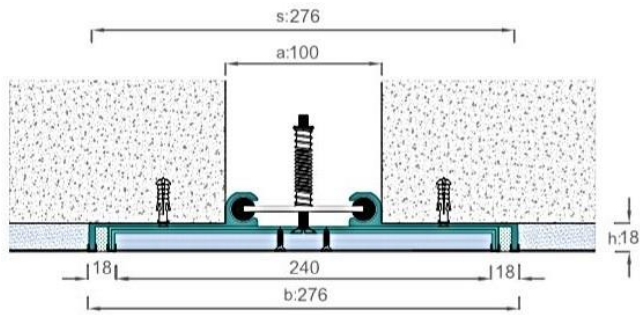

» COR 150_234

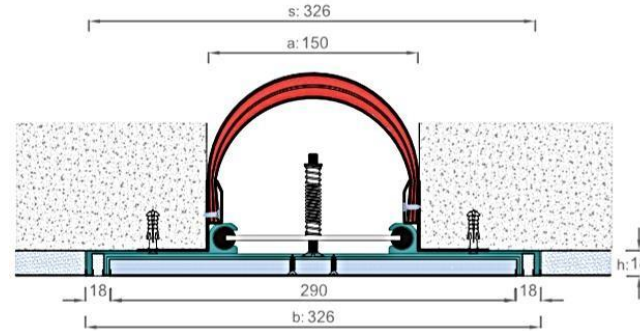

» COR 150K_234

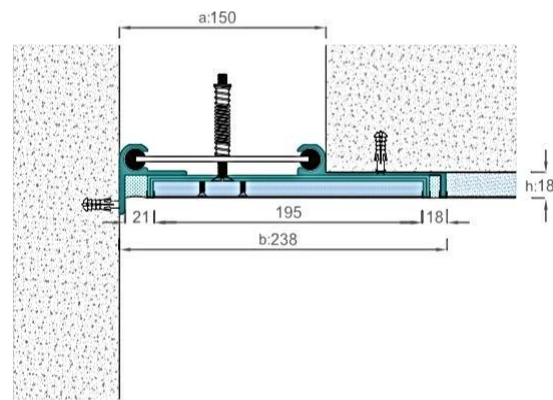

Juntas sísmicas de suelos,
paredes y techos
Seismic floor, wall, ceiling
profiles

Las juntas sísmicas COR 234 son compatibles con las juntas de expansión de suelo de la serie COR 804.

COR 234 seismic series are compatible with COR 804 series floor expansion joint profiles.



REF	DESCRIPCIÓN DESCRIPTION	ANCHO CONJUNTO (a) mm JOINT WIDTH	SUPERFICIE VISIBLE (b) mm SURFACE VISIBLE	ALTURA PERFIL (h) mm PROFILE HEIGHT	ANCHO TOTAL (s) mm TOTAL WIDTH	SUPERFICIE SURFACE	CAPACIDAD DE MOVIMIENTO MOVEMENT CAPACITY
COR_100234	Adecuado para cerámica, placas de yeso / superficie de acero inoxidable Suitable with ceramic, dry wall and etc / Stainless steel surface	100	276	18	276	Aço inoxidável + Selante + tampa Stainless steel + Sealant + Cover	± 50
COR_150234	Adecuado para cerámica, placas de yeso / superficie de acero inoxidable Suitable with ceramic, dry wall and etc / Stainless steel surface	150	326	18	326	Aço inoxidável + Selante + tampa Stainless steel + Sealant + Cover	± 75
COR_200234	Adecuado para cerámica, placas de yeso / superficie de acero inoxidable Suitable with ceramic, dry wall and etc / Stainless steel surface	200	376	18	376	Aço inoxidável + Selante + tampa Stainless steel + Sealant + Cover	± 75
COR_250234	Adecuado para cerámica, placas de yeso / superficie de acero inoxidable Suitable with ceramic, dry wall and etc / Stainless steel surface	250	426	18	426	Aço inoxidável + Selante + tampa Stainless steel + Sealant + Cover	± 75
COR_300234	Adecuado para cerámica, placas de yeso / superficie de acero inoxidable Suitable with ceramic, dry wall and etc / Stainless steel surface	300	476	18	476	Aço inoxidável + Selante + tampa Stainless steel + Sealant + Cover	± 75

Juntas sísmicas incorporadas para montaje en pared y techo.
 Flush mounted seismic wall and ceiling joint profiles.

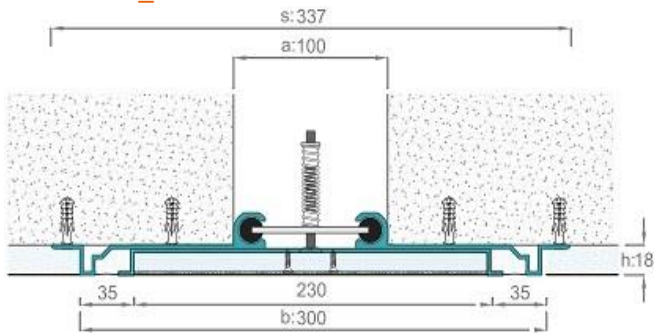

» COR 100_236

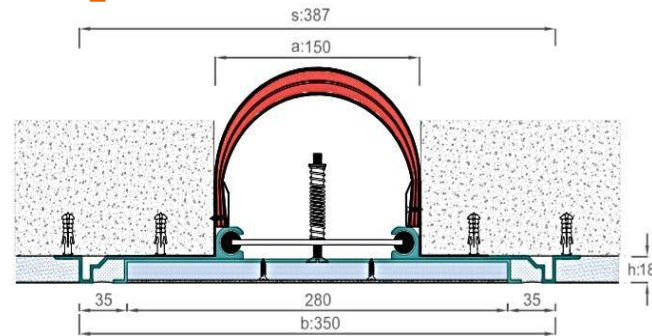

» COR 150_236

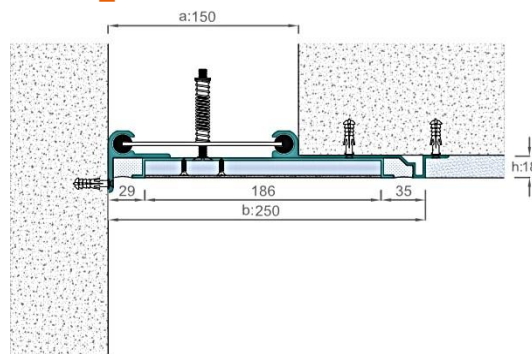

» COR 150K_236

 Juntas sísmicas de suelos,
 paredes y techos.
 Seismic floor, wall, ceiling
 profiles

Las juntas de pared y techo COR 236 son adecuadas para lugares donde se han utilizado juntas de expansión sísmica de suelo sísmica COR 806.

COR 236 wall and ceiling series are suitable to places where COR 806 seismic floor expansion joint profiles have been used.



REF	DESCRIPCIÓN DESCRIPTION	ANCHO CONJUNTO (a) mm JOINT WIDTH	SUPERFICIE VISIBLE (b) mm SURFACE VISIBLE	ALTURA PERFIL (h) mm PROFILE HEIGHT	ANCHO TOTAL (s) mm TOTAL WIDTH	SUPERFICIE SURFACE	CAPACIDAD DE MOVIMIENTO MOVEMENT CAPACITY
COR_100_236	Adecuado con solado de cerámica, placa de yeso / aplicación de sellador Suitable with screed ceramic, dry wall and etc / Sealant application	100	300	18	337	Acabado Alu + Sellador + cubierta Mill finish ALU + Sealant + Cover	± 50
COR_150_236	Adecuado con solado de cerámica, placa de yeso / aplicación de sellador Suitable with screed ceramic, dry wall and etc / Sealant application	150	350	18	387	Acabado Alu + Sellador + cubierta Mill finish ALU + Sealant + Cover	± 70
COR_200_236	Adecuado con solado de cerámica, placa de yeso / aplicación de sellador Suitable with screed ceramic, dry wall and etc / Sealant application	200	400	18	437	Acabado Alu + Sellador + cubierta Mill finish ALU + Sealant + Cover	± 100
COR_250_236	Adecuado con solado de cerámica, placa de yeso / aplicación de sellador Suitable with screed ceramic, dry wall and etc / Sealant application	250	550	18	587	Acabado Alu + Sellador + cubierta Mill finish ALU + Sealant + Cover	± 125
COR_300_236	Adecuado con solado de cerámica, placa de yeso / aplicación de sellador Suitable with screed ceramic, dry wall and etc / Sealant application	300	600	18	637	Acabado Alu + Sellador + cubierta Mill finish ALU + Sealant + Cover	± 150
COR_350_236	Adecuado con solado de cerámica, placa de yeso / aplicación de sellador Suitable with screed ceramic, dry wall and etc / Sealant application	350	650	18	687	Acabado Alu + Sellador + cubierta Mill finish ALU + Sealant + Cover	± 175
COR_400_236	Adecuado con solado de cerámica, placa de yeso / aplicación de sellador Suitable with screed ceramic, dry wall and etc / Sealant application	400	700	18	737	Acabado Alu + Sellador + cubierta Mill finish ALU + Sealant + Cover	± 200
COR_450_236	Adecuado con solado de cerámica, placa de yeso / aplicación de sellador Suitable with screed ceramic, dry wall and etc / Sealant application	450	750	18	787	Acabado Alu + Sellador + cubierta Mill finish ALU + Sealant + Cover	± 200
COR_500_236	Adecuado con solado de cerámica, placa de yeso / aplicación de sellador Suitable with screed ceramic, dry wall and etc / Sealant application	500	800	18	837	Acabado Alu + Sellador + cubierta Mill finish ALU + Sealant + Cover	± 200

Juntas sísmicas incorporadas para montaje en pared y techo
 Flush mounted seismic wall and ceiling joint profiles

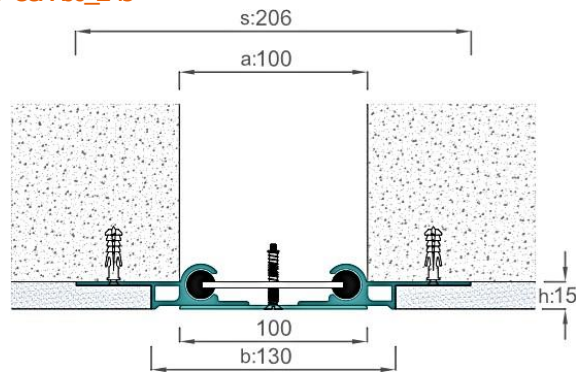

»» COR 100_243

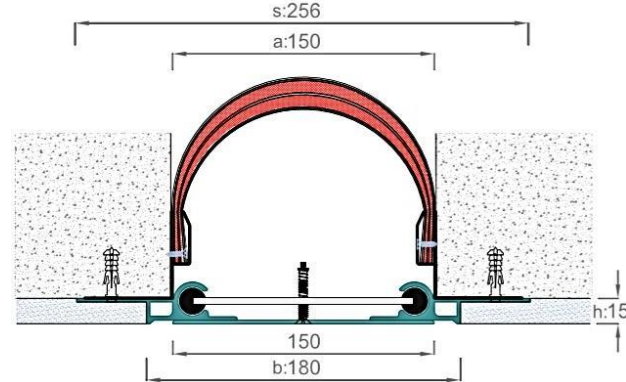

»» COR 150_243

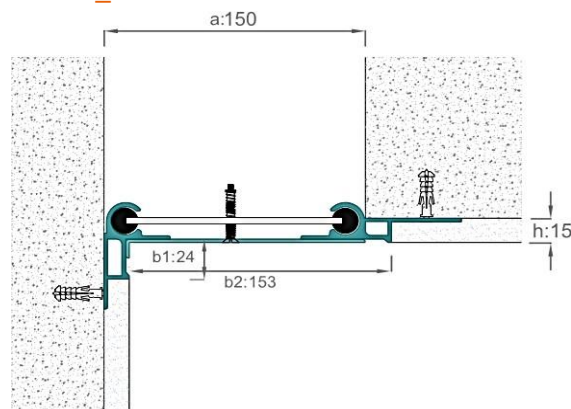

»» COR 150K_243

 Juntas sísmicas de suelos,
 paredes y techos
 Seismic floor, wall, ceiling
 profiles

La junta COR 243 es la preferida por su superficie superior brillante, donde se utilizó la junta COR 813 en el suelo.
 COR 243 series are preferred with its shiny top surface where COR 813 series has been used on the floor.



REF	DESCRIPCIÓN DESCRIPTION	ANCHO CONJUNTO (a) mm JOINT WIDTH	SUPERFICIE VISIBLE (b) mm SURFACE VISIBLE	ALTURA PERFIL (h) mm PROFILE HEIGHT	ANCHO TOTAL (s) mm TOTAL WIDTH	SUPERFICIE SURFACE	CAPACIDAD DE MOVIMIENTO MOVEMENT CAPACITY
COR_100_243	Adecuado para solado, placa de yeso / superficie superior en acero inoxidable Suitable with screed, dry wall and etc. / Stainless steel top surface	100	130	15	206	Acabado Alu + Acero Inoxidable Mill finish ALU + Stainless steel	+40/-50
COR_150_243	Adecuado para solado, placa de yeso / superficie superior en acero inoxidable Suitable with screed, dry wall and etc. / Stainless steel top surface	150	180	15	256	Acabado Alu + Acero Inoxidable Mill finish ALU + Stainless steel	+60/-75
COR_200_243	Adecuado para solado, placa de yeso / superficie superior en acero inoxidable Suitable with screed, dry wall and etc. / Stainless steel top surface	200	230	15	306	Acabado Alu + Acero Inoxidable Mill finish ALU + Stainless steel	+60/-100
COR_250_243	Adecuado para solado, placa de yeso / superficie superior en acero inoxidable Suitable with screed, dry wall and etc. / Stainless steel top surface	250	280	15	356	Acabado Alu + Acero Inoxidable Mill finish ALU + Stainless steel	+60/-125
COR_300_243	Adecuado para solado, placa de yeso / superficie superior en acero inoxidable Suitable with screed, dry wall and etc. / Stainless steel top surface	300	330	15	406	Acabado Alu + Acero Inoxidable Mill finish ALU + Stainless steel	+60/-150

Juntas sísmicas de pared y techo montadas en superficie
 Surface mounted seismic wall and ceiling expansion joint profiles

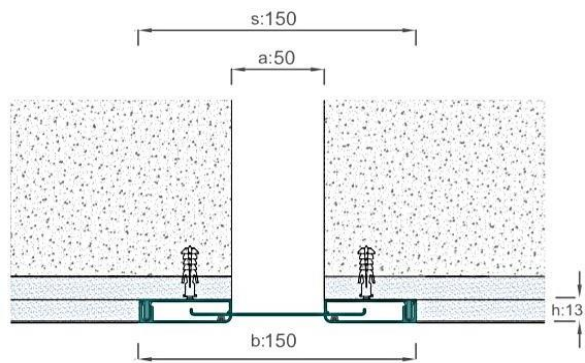
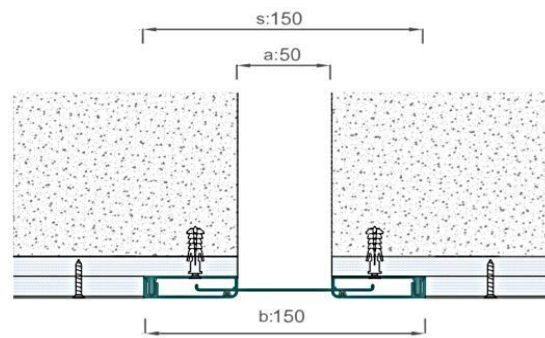

» COR050_281

 » COR050_281 Alternativa de aplicación de pared seca de doble capa
 Double layered dry wall application alternative

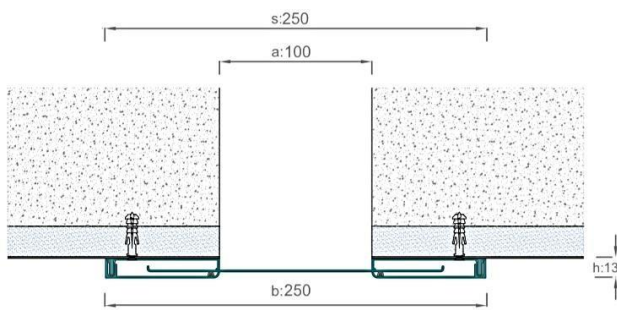
» COR100_281

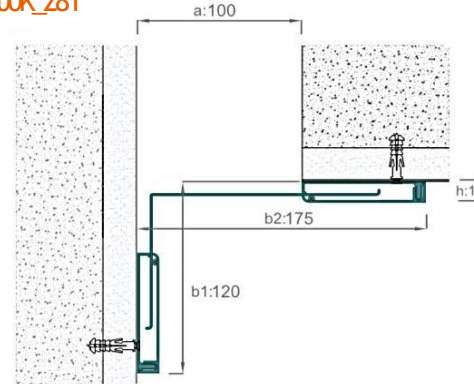

» COR100K_281

 Juntas sísmicas de suelos,
 paredes y techos
 Seismic floor, wall, ceiling
 profiles

Las juntas de expansión de pared y techo son adecuadas para todo tipo de revestimientos de pared con superficie superior de aluminio especial. Se puede entregar con recubrimiento anodizado o polvo. Adaptable con la mayoría de las juntas de expansión de suelo.

Wall and ceiling profiles are suitable for all kinds of wall coverings with the special aluminum top surface. Can be delivered by anodized or powder coated. Adoptable with most types of floor expansion joint profiles.



REF	DESCRIPCIÓN DESCRIPTION	ANCHO CONJUNTO (a) mm JOINT WIDTH	SUPERFICIE VISIBLE (b) mm SURFACE VISIBLE	ALTURA PERFIL (h) mm PROFILE HEIGHT	ANCHO TOTAL (s) mm TOTAL WIDTH	SUPERFICIE SURFACE	CAPACIDAD DE MOVIMIENTO MOVEMENT CAPACITY
COR_050_281	Superficie superior de aluminio, junta sísmica de pared y techo anodizado Aluminum top surface, anodized seismic wall and ceiling profile	50	150	13	150	Aluminio anodizado Aluminum anodised	± 40
COR_100_281	Superficie superior de aluminio, junta sísmica de pared y techo anodizado Aluminum top surface, anodized seismic wall and ceiling profile	100	250	13	250	Aluminio anodizado Aluminum anodised	± 50
COR_150_281	Superficie superior de aluminio, junta sísmica de pared y techo anodizado Aluminum top surface, anodized seismic wall and ceiling profile	150	300	13	300	Aluminio anodizado Aluminum anodised	± 165
COR_200_281	Superficie superior de aluminio, junta sísmica de pared y techo anodizado Aluminum top surface, anodized seismic wall and ceiling profile	200	350	13	350	Aluminio anodizado Aluminum anodised	± 165
COR_250_281	Superficie superior de aluminio, junta sísmica de pared y techo anodizado Aluminum top surface, anodized seismic wall and ceiling profile	250	400	13	400	Aluminio anodizado Aluminum anodised	± 65
COR_300_281	Superficie superior de aluminio, junta sísmica de pared y techo anodizado Aluminum top surface, anodized seismic wall and ceiling profile	300	450	13	450	Aluminio anodizado Aluminum anodised	± 65

Juntas sísmicas de pared y techo montadas en superficie
Surface mounted seismic wall and ceiling expansion joint profiles

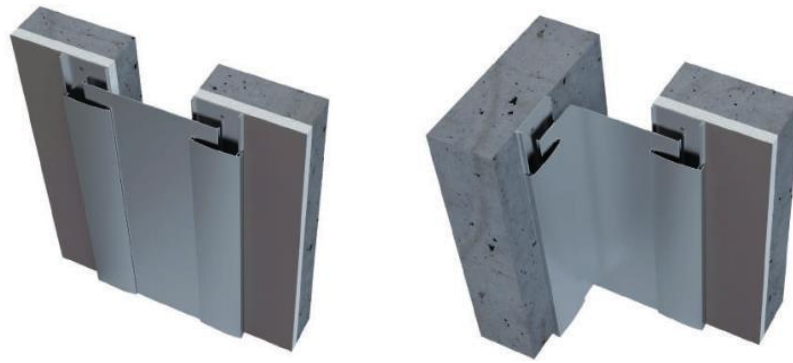

» COR 100_291

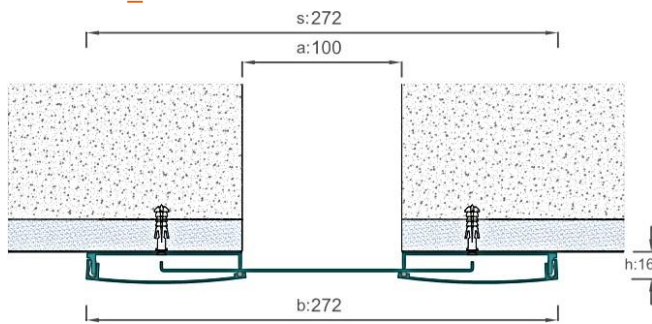

» COR 100K_291

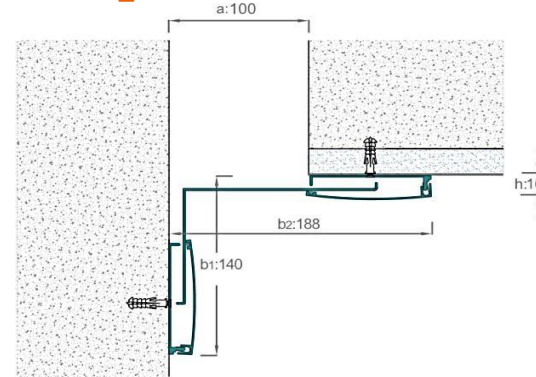

» COR 150_291

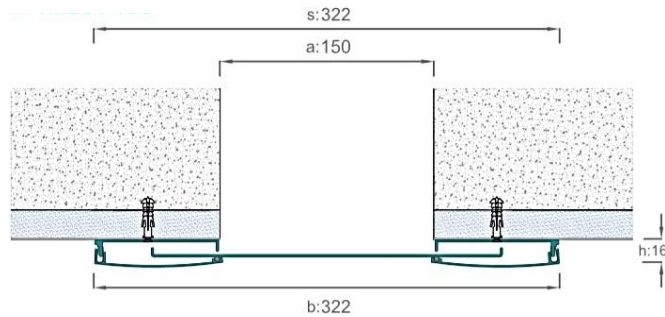

» COR 150K_291

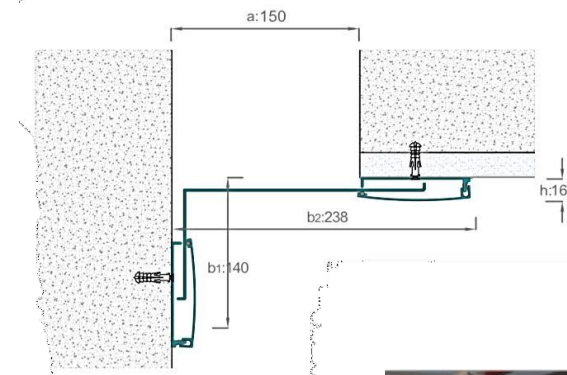

Juntas sísmicas de suelos,
paredes y techos
Seismic floor, wall, ceiling
profiles

Las juntas sísmicas de pared y techo tienen una amplia superficie lateral decorativa. Se puede entregar con recubrimiento en polvo o anodizado.

Seismic wall and ceiling profiles have the wide and decorative side surface. Can be delivered by powder coated or anodized.

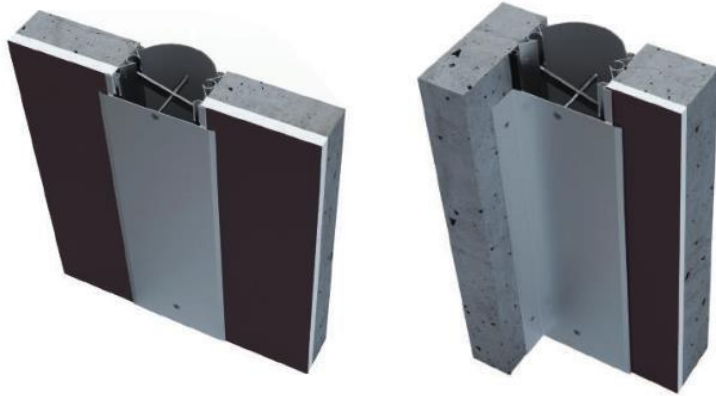

REF	DESCRIPCIÓN DESCRIPTION	ANCHO CONJUNTO (a) mm JOINT WIDTH	SUPERFICIE VISIBLE (b) mm SURFACE VISIBLE	ALTURA PERFIL (h) mm PROFILE HEIGHT	ANCHO TOTAL (s) mm TOTAL WIDTH	SUPERFICIE SURFACE	CAPACIDAD DE MOVIMIENTO MOVEMENT CAPACITY
COR_050_291	Superficie superior de aluminio, junta sísmica de pared y techo anodizado Aluminum top surface, anodized seismic wall and ceiling profile	50	222	16	222	Aluminio anodizado Aluminum anodised	± 50
COR_100_291	Superficie superior de aluminio, junta sísmica de pared y techo anodizado Aluminum top surface, anodized seismic wall and ceiling profile	100	272	16	272	Aluminio anodizado Aluminum anodised	± 75
COR_150_291	Superficie superior de aluminio, junta sísmica de pared y techo anodizado Aluminum top surface, anodized seismic wall and ceiling profile	150	322	16	322	Aluminio anodizado Aluminum anodised	± 75
COR_200_291	Superficie superior de aluminio, junta sísmica de pared y techo anodizado Aluminum top surface, anodized seismic wall and ceiling profile	200	372	16	372	Aluminio anodizado Aluminum anodised	± 75
COR_250_291	Superficie superior de aluminio, junta sísmica de pared y techo anodizado Aluminum top surface, anodized seismic wall and ceiling profile	250	422	16	422	Aluminio anodizado Aluminum anodised	± 75
COR_300_291	Superficie superior de aluminio, junta sísmica de pared y techo anodizado Aluminum top surface, anodized seismic wall and ceiling profile	300	472	16	472	Aluminio anodizado Aluminum anodised	± 75
COR_350_291	Superficie superior de aluminio, junta sísmica de pared y techo anodizado Aluminum top surface, anodized seismic wall and ceiling profile	350	522	16	522	Aluminio anodizado Aluminum anodised	± 75
COR_400_291	Superficie superior de aluminio, junta sísmica de pared y techo anodizado Aluminum top surface, anodized seismic wall and ceiling profile	400	572	16	572	Aluminio anodizado Aluminum anodised	± 75

Juntas sísmicas de pared y techo montadas en superficie
 Surface mounted seismic wall and ceiling expansion joint profiles

» COR 100_286

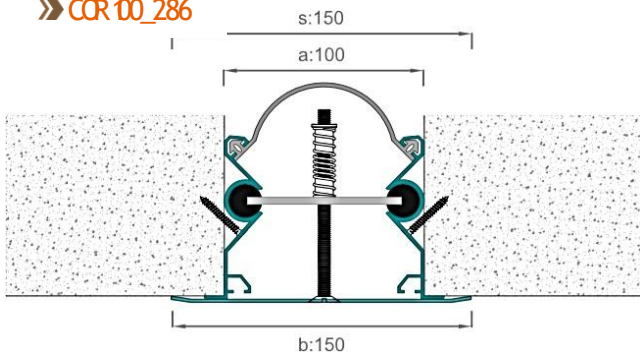

» COR 100K_286

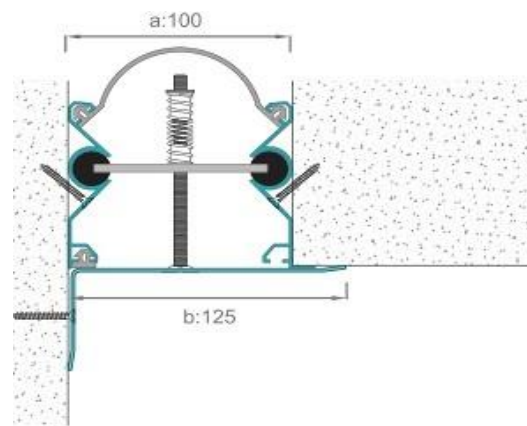

» COR 150_286

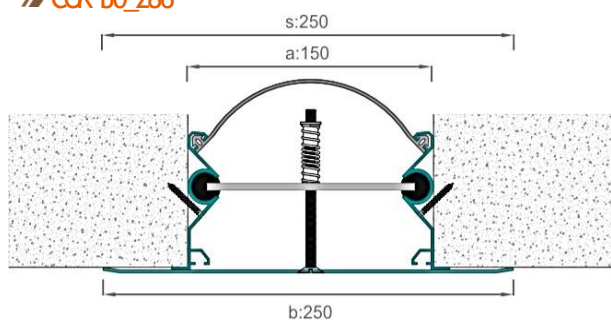

» COR 150K_286

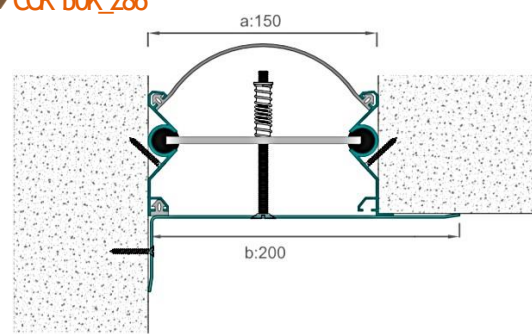
 Juntas sísmicas de suelos,
 paredes y techos
 Seismic floor, wall, ceiling
 profiles

Las juntas de expansión de pared y techo COR 286 tienen barreras de vapor y capacidad de dirección tridimensional. (con tornillo montado en el medio). Especialmente adecuado para fachadas.

COR 286 wall and ceiling expansion joint profiles have vapor barriers and movement capacity in 3-dimensional direction. (with screw mounted in the middle). Especially suitable for facade.



REF	DESCRIPCIÓN DESCRIPTION	ANCHO CONJUNTO (a) mm JOINT WIDTH	SUPERFICIE VISIVEL (b) mm SURFACE VISIBLE	ANCHO TOTAL (s) mm TOTAL WIDTH	SUPERFICIE SURFACE	CAPACIDAD DE MOVIMIENTO MOVEMENT CAPACITY
COR_100_286	Pared de superficie superior de aluminio y junta de techo anodizado. Anodized, aluminum top surface seismic wall and ceiling profile	100	150	206	Aluminio anodizado Aluminum anodised	+40/-50
COR_150_286	Pared de superficie superior de aluminio y junta de techo anodizado. Anodized, aluminum top surface seismic wall and ceiling profile	150	250	256	Aluminio anodizado Aluminum anodised	+60/-75
COR_200_286	Pared de superficie superior de aluminio y junta de techo anodizado. Anodized, aluminum top surface seismic wall and ceiling profile	200	350	306	Aluminio anodizado Aluminum anodised	+60/-100
COR_250_286	Pared de superficie superior de aluminio y junta de techo anodizado. Anodized, aluminum top surface seismic wall and ceiling profile	250	400	356	Aluminio anodizado Aluminum anodised	+60/-125
COR_300_286	Pared de superficie superior de aluminio y junta de techo anodizado. Anodized, aluminum top surface seismic wall and ceiling profile	300	500	406	Aluminio anodizado Aluminum anodised	+60/-150

Juntas sísmicas de pared y techo montadas en superficie.
Surface mounted seismic wall and ceiling expansion joint profiles.



» COR 100_293

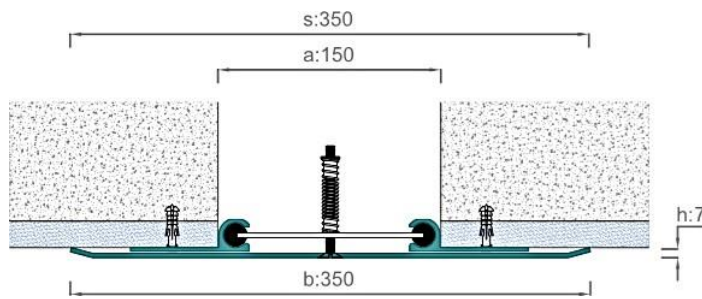

» COR 150_293

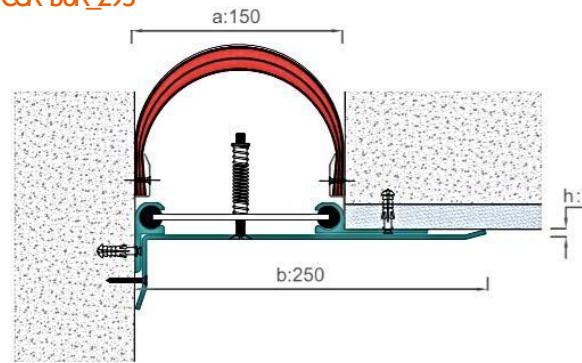

» COR 200_293

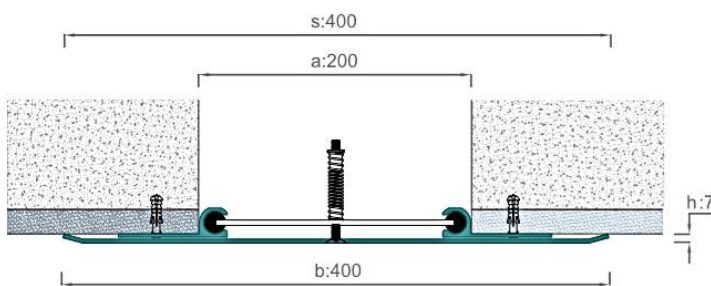

» COR 250_293

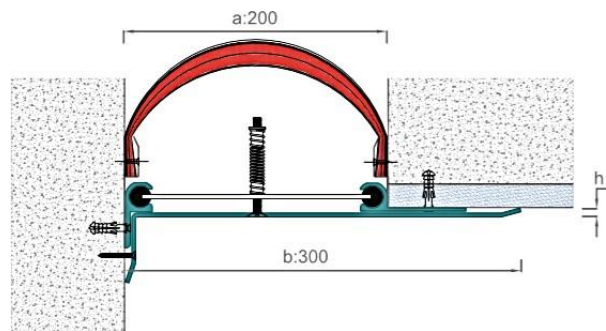

Juntas sísmicas de suelos,
paredes y techos
Seismic floor, wall, ceiling
profiles

Las juntas de expansión del techo son adecuadas para paredes y techos de estacionamientos y paredes donde se requiere una gran capacidad de manipulación. Puede ser producido por anodizado o recubierto de polvo en el color deseado.

Cover expansion joint profiles are suitable for car park walls and ceilings and walls where large movement capacity is being required. Can be produced by anodized or powder coated in required color.



REF	DESCRIPCIÓN DESCRIPTION	ANCHO CONJUNTO (a) mm JOINT WIDTH	SUPERFICIE VISIBLE (b) mm SURFACE VISIBLE	ALTURA PERFIL (h) mm PROFILE HEIGHT	ANCHO TOTAL (s) mm TOTAL WIDTH	SUPERFICIE SURFACE	CAPACIDAD DE MOVIMIENTO MOVEMENT CAPACITY
COR_100_293	Pared de superficie superior de aluminio y junta de techo anodizado. Anodized, aluminum top surface seismic wall and ceiling profile.	100	300	7	300	Aluminio anodizado Aluminum anodised	± 50
COR_150_293	Pared de superficie superior de aluminio y junta de techo anodizado. Anodized, aluminum top surface seismic wall and ceiling profile.	150	350	7	350	Aluminio anodizado Aluminum anodised	± 75
COR_200_293	Pared de superficie superior de aluminio y junta de techo anodizado. Anodized, aluminum top surface seismic wall and ceiling profile.	200	400	7	400	Aluminio anodizado Aluminum anodised	± 100
COR_250_293	Pared de superficie superior de aluminio y junta de techo anodizado. Anodized, aluminum top surface seismic wall and ceiling profile.	250	500	7	500	Aluminio anodizado Aluminum anodised	± 125
COR_300_293	Pared de superficie superior de aluminio y junta de techo anodizado. Anodized, aluminum top surface seismic wall and ceiling profile.	300	600	7	600	Aluminio anodizado Aluminum anodised	± 150

Juntas de estacionamiento
Car park expansion joint profiles



Junta de ampliación de pavimentos para aparcamientos
 Car park flush mounted floor expansion joint profiles

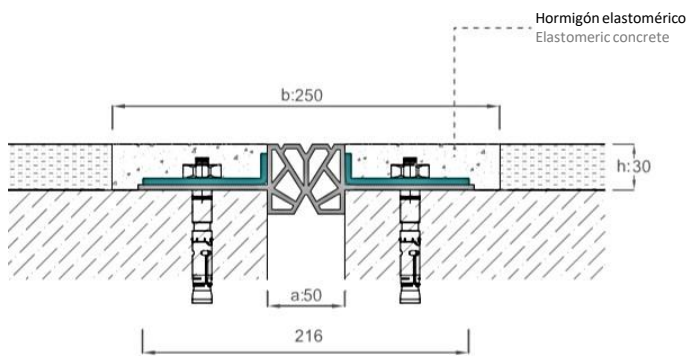

>> COR_050_910

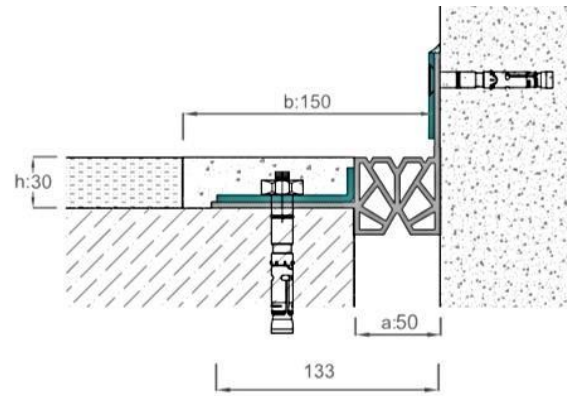

>> COR_050K_910 (Detalle de la esquina / Corner detail)

 Perfiles conjuntos de expansión
 de estacionamiento
 Car park expansion joint profiles

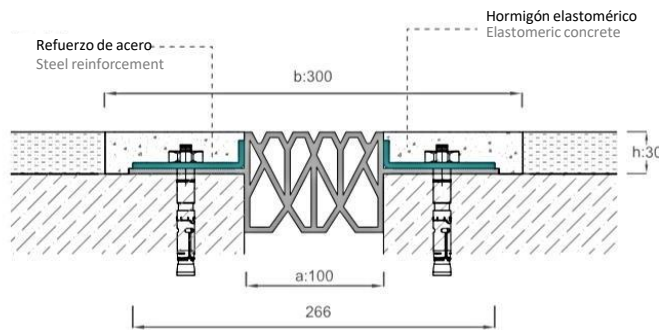
>> COR_100_910



>> COR_100K_910 (Detalle de la esquina / Corner detail)

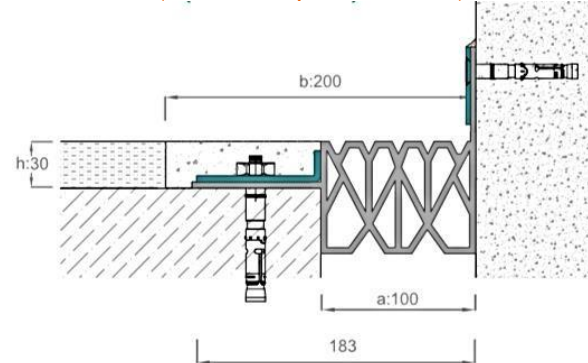

Las juntas de expansión de aparcamientos basadas en TPE y TPV pueden llegar al suelo en solo una hora. Con características tales como alta capacidad de flexión y contracción y resistente a la corrosión, la serie COR 910 es adecuada para aplicar hormigón base altamente polimérico.

TPE and TPV based car park expansion joint profiles are able to the ground in only an hour time. Having such characteristics as high capacity to bend Shrink and resistant to corrosion make COR 910 Series Suitable to apply highly polymeric based concrete.



REF	DESCRIPCIÓN DESCRIPTION	ANCHO CONJUNTO (a) mm JOINT WIDTH	SUPERFICIE VISIBLE (b) mm SURFACE VISIBLE	ALTURA (h) mm PROFILE HEIGHT	ANCHO (s) mm TOTAL WIDTH	SUPERFICIE SURFACE	CAPACIDAD DE MOVIMIENTO MOVEMENT CAPACITY	CAPACIDAD DE CARGA LOAD CAPACITY
COR_050910	Montado con juntas de acero Assembled with steel profiles	50	250	30	250	TPE + Acero TPE + Steel	± 25	30 Ton
COR_100910	Montado con juntas de acero Assembled with steel profiles	100	300	30	300	TPE + Acero TPE + Steel	± 50	30 Ton

Junta de ampliación de pavimentos para aparcamientos.
 Car park flush mounted floor expansion joint profiles.

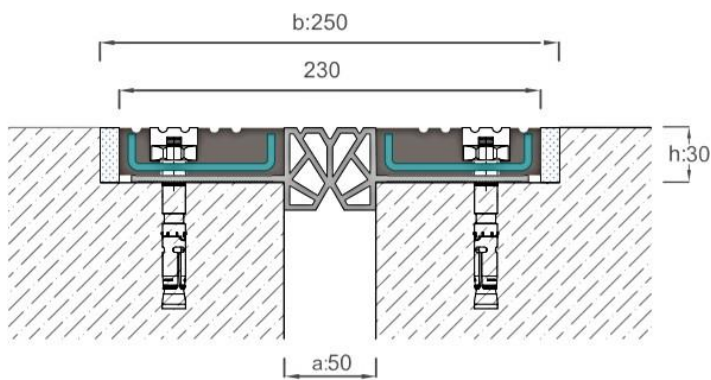

» COR050_911

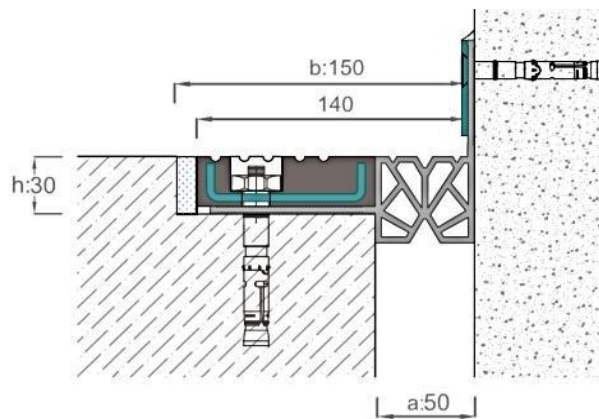

» COR050K_910 (Detalle de la esquina / Corner detail)

 Perfiles conjuntos de expansión
 de estacionamiento
 Car park expansion joint profiles.

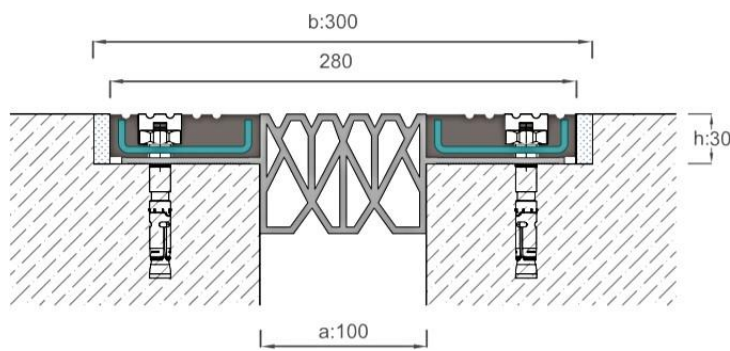
» COR100_911



» COR100K_911 (Detalle de la esquina / Corner detail)

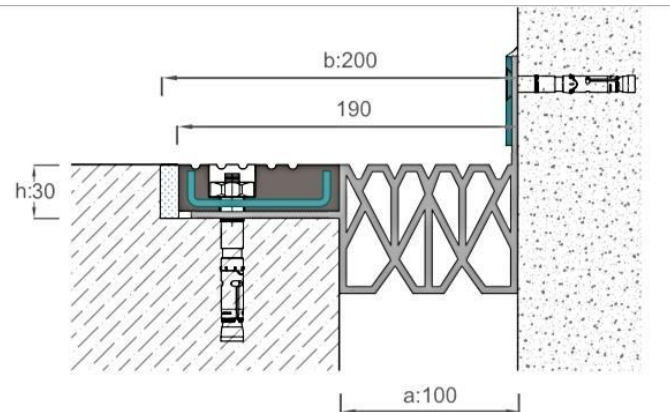

Las piezas intermedias TPV y TPE son resistentes a cargas pesadas, cómodas, silenciosas e impermeables cuando se montan correctamente. Además, las juntas laterales vulcanizadas están reforzadas con placas de acero.

TPV AND TPE middle parts are resistant to heavy loads, comfortable, quite and waterproofing when mounted properly. Furthermore, vulcanized side profiles are reinforced with steel plates.

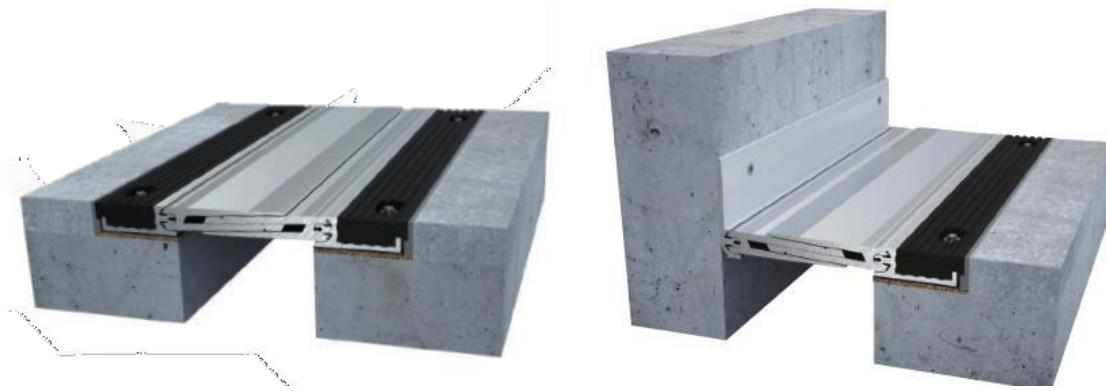

REF	DESCRIPCIÓN DESCRIPTION	ANCHO CONJUNTO (a) mm JOINT WIDTH	SUPERFICIE VISIVEL (b) mm SURFACE VISIBLE	ALTURA (h) mm PROFILE HEIGHT	ANCHO (s) mm TOTAL WIDTH	SUPERFICIE SURFACE	CAPACIDAD DE MOVIMIENTO MOVEMENT CAPACITY	CAPACIDAD DE CARGA LOAD CAPACITY
COR_050911	Juntas de suelo compuestas reforzadas de acero. Steel reinforced composite floor profile.	50	250	30	250	Caucho + TPE Rubber + TPE	± 25	30 Ton
COR_051911	Perfil de suelo compuesto reforzado de acero. Steel reinforced composite floor profile.	50	250	30	250	Caucho + TPE Rubber + TPE	± 40	30 Ton
COR_100911	Perfil de suelo compuesto reforzado de acero. Steel reinforced composite floor profile.	100	300	30	300	Caucho + TPE Rubber + TPE	± 50	30 Ton

Junta de ampliación de pavimentos para aparcamientos
 Car park flush mounted floor expansion joint profiles

>> COR 50_911

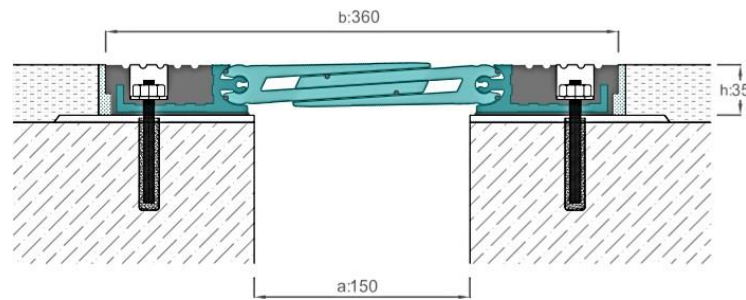

>> COR 200_911

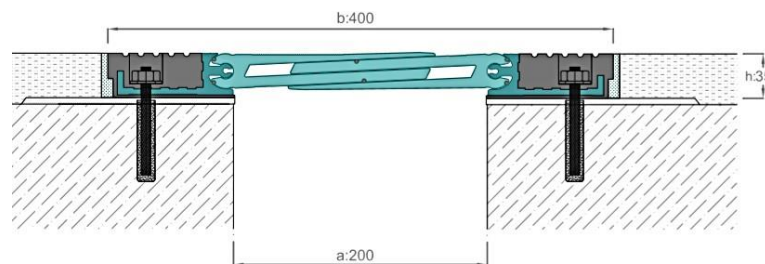

>> COR 500_911

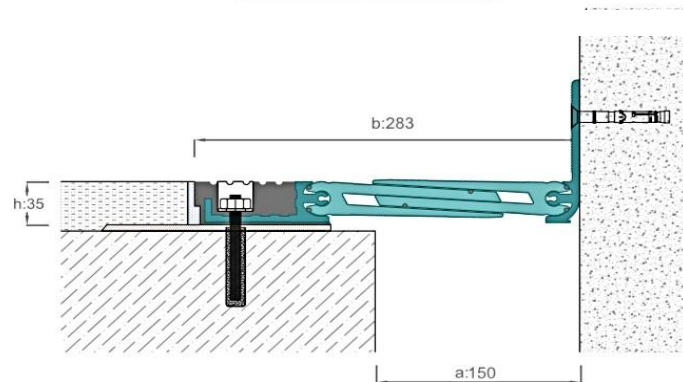
 Perfiles conjuntos de expansión
 de estacionamiento
 Car park expansion joint profiles

Desarrolladas por primera vez en el mundo, estas juntas de expansión de caucho + aluminio se han aplicado con éxito en amplias distancias de juntas de expansión en aparcamientos y en estructuras industriales.

Created for the first time in the world, these rubber + aluminum dilatation profiles successfully applied to wide expansion joint gaps in carparks and industrial structures. Provide opportunity to be quite and comfortable.



REF	DESCRIPCIÓN DESCRIPTION	ANCHO CONJUNTO (a) mm JOINT WIDTH	SUPERFICIE VISIBLE (b) mm SURFACE VISIBLE	ALTURA (h) mm PROFILE HEIGHT	ANCHO (s) mm TOTAL WIDTH	SUPERFICIE SURFACE	CAPACIDAD DE MOVIMIENTO MOVEMENT CAPACITY	CAPACIDAD DE CARGA LOAD CAPACITY
COR_150_911	Juntas de suelo compuestas, caucho y aluminio. Composite, rubber, aluminum floor profile	150	360	35	360	Acabado ALU + Caucho. Mill finish ALU + Rubber	+35/-25	30 Ton
COR_200_911	Juntas de suelo compuestas, caucho y aluminio. Composite, rubber, aluminum floor profile	200	400	35	400	Acabado ALU + Caucho. Mill finish ALU + Rubber	± 40	16 Ton
COR_250_911	Juntas de suelo compuestas, caucho y aluminio. Composite, rubber, aluminum floor profile	250	450	35	450	Acabado ALU + Caucho. Mill finish ALU + Rubber	± 40	9 Ton
COR_300_911	Juntas de suelo compuestas, caucho y aluminio. Composite, rubber, aluminum floor profile	300	500	35	500	Acabado ALU + Caucho. Mill finish ALU + Rubber	± 40	6,5 Ton

Juntas de ampliación de suelos superficiales para aparcamientos
 Car park surface mounted floor expansion joint profiles

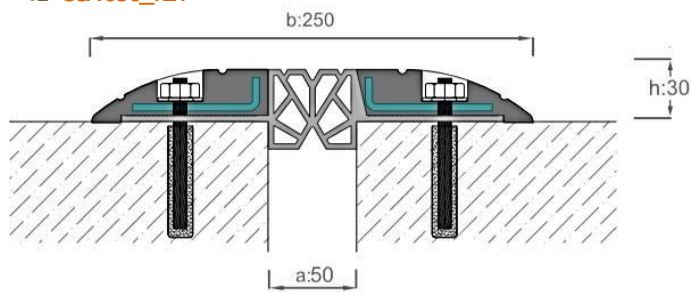

» COR050_921

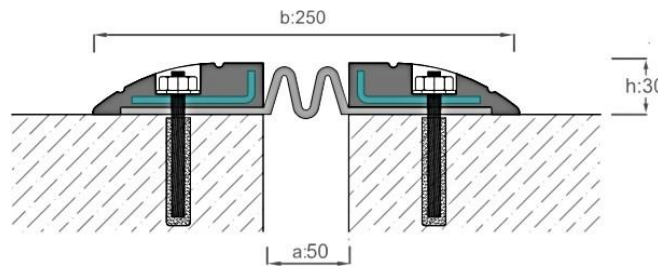

» COR051_921

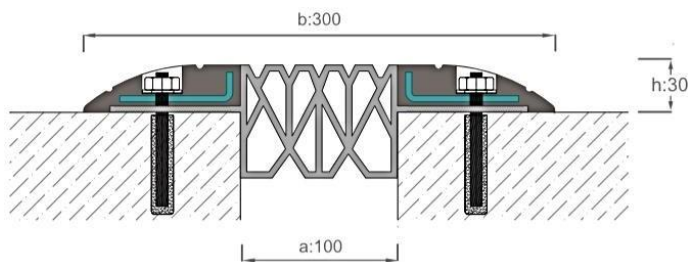

» COR100_921

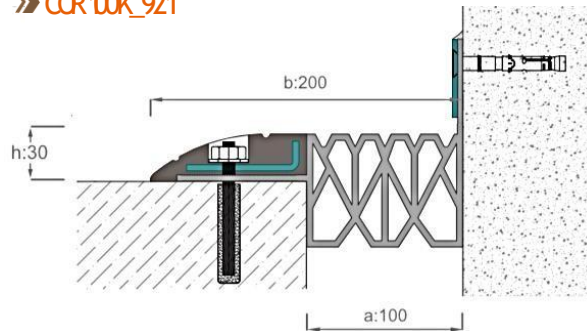

» COR100K_921

 Perfiles conjuntos de expansión
 de estacionamiento
 Car park expansion joint profiles

La serie COR 921 son juntas de expansión de caucho y acero. Aplicado en suelos en juntas de acabado y se puede utilizar como amortiguador de velocidad. Se monta en el suelo por anclajes de acero adecuados para tener juntas de 25 cm en el medio.

COR 921 series are rubber + steel composite expansion joint profiles. Applied to floors over finish profiles and can be used as a speed bumper. Ass wall assembled to the floor by appropriate steel anchors of having 25cm gaps in between.



REF	DESCRIPCIÓN DESCRIPTION	ANCHO CONJUNTO (a) mm JOINT WIDTH	SUPERFICIE VISIBLE (b) mm SURFACE VISIBLE	ALTURA (h) mm PROFILE HEIGHT	ANCHO (s) mm TOTAL WIDTH	SUPERFICIE SURFACE	CAPACIDAD DE MOVIMIENTO MOVEMENT CAPACITY	CAPACIDAD DE CARGA LOAD CAPACITY
COR_050_921	Parachoques de velocidad, compuesto, caucho, junta de acero. Speed bumper, Composite, rubber, steel profile	50	250	30	250	Caucho + TPE Rubber + TPE	± 25	9 Ton
COR_051_921	Parachoques de velocidad, compuesto, caucho, junta de acero. Speed bumper, Composite, rubber, steel profile	50	250	30	250	Caucho + TPE Rubber + TPE	± 40	9 Ton
COR_100_921	Parachoques de velocidad, compuesto, caucho, junta de acero Speed bumper, Composite, rubber, steel profile	100	300	30	300	Caucho + TPE Rubber + TPE	± 50	9 Ton
COR_101_921	Parachoques de velocidad, compuesto, caucho, junta de acero Speed bumper, Composite, rubber, steel profile	100	300	30	300	Acabado ALU + Caucho Mill finish ALU + Rubber	± 20	9 Ton
COR_150_921	Parachoques de velocidad, compuesto, caucho, junta de acero Speed bumper, Composite, rubber, steel profile	150	350	30	350	Acabado ALU + Caucho Mill finish ALU + Rubber	± 20	9 Ton
COR_200_921	Parachoques de velocidad, compuesto, caucho, junta de acero. Speed bumper, Composite, rubber, steel profile	200	462	35	462	Acabado ALU + Caucho Mill finish ALU + Rubber	± 40	9 Ton
COR_250_921	Parachoques de velocidad, compuesto, caucho, junta de acero Speed bumper, Composite, rubber, steel profile	250	512	35	512	Acabado ALU + Caucho Mill finish ALU + Rubber	± 50	9 Ton
COR_300_921	Parachoques de velocidad, compuesto, caucho, junta de acero Speed bumper, Composite, rubber, steel profile	300	562	35	562	Acabado ALU + Caucho Mill finish ALU + Rubber	± 60	9 Ton

Junta de ampliación de pavimentos para aparcamientos
Car park flush mounted floor expansion joint profiles



» COR 01_921

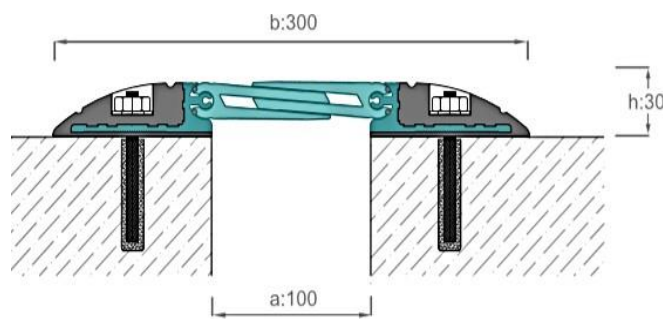

» COR 150_921

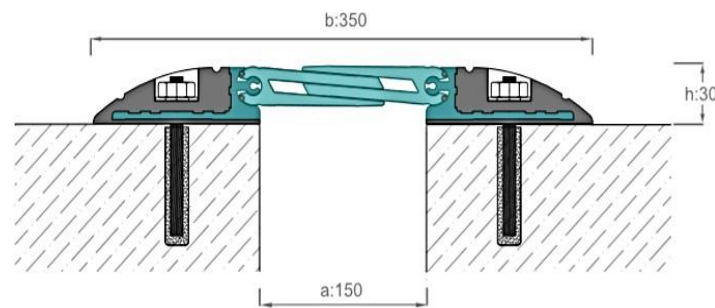

Perfiles conjuntos de expansión
de estacionamiento
Car park expansion joint profiles

» COR 200_921

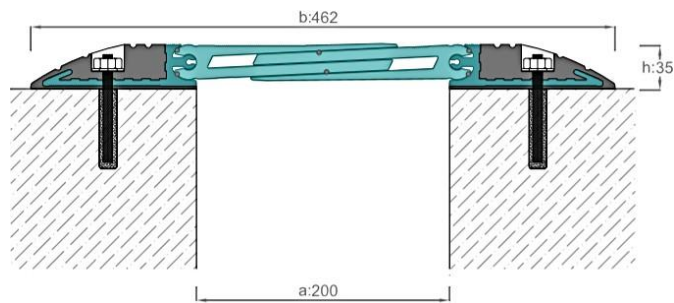

» Detalle de la esquina / Corner detail

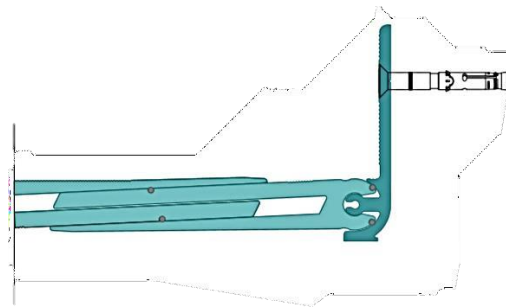

Desarrolladas por primera vez en el mundo, las juntas de expansión de aluminio + caucho TPE también presentan los detalles de las esquinas de cada proyecto.
Developed of the first time in the world, aluminum + TPE rubber expansion joint profiles also have the corner detail in each design.

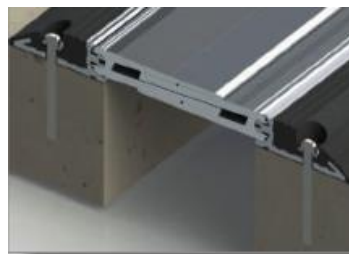

Junta de ampliación de pavimentos para aparcamientos
 Car park flush mounted floor expansion joint profiles

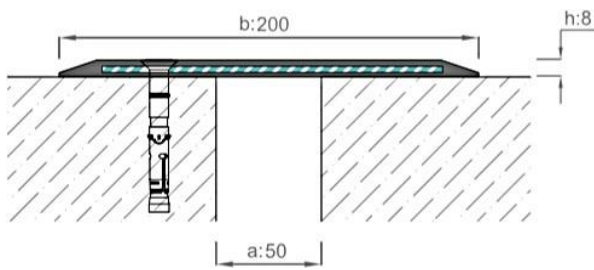

» COR_050_951

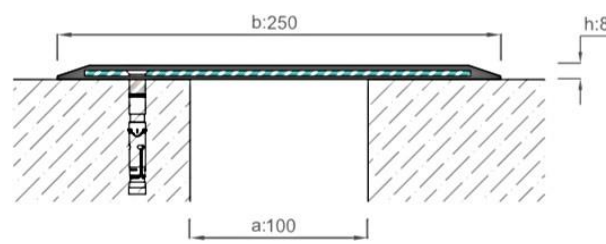

» COR_100_951

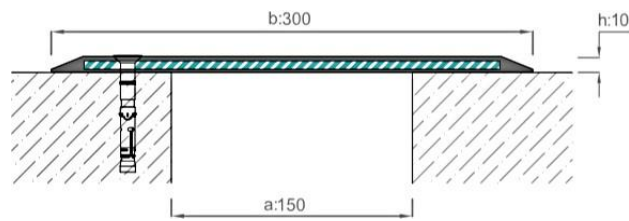

» COR_150_951

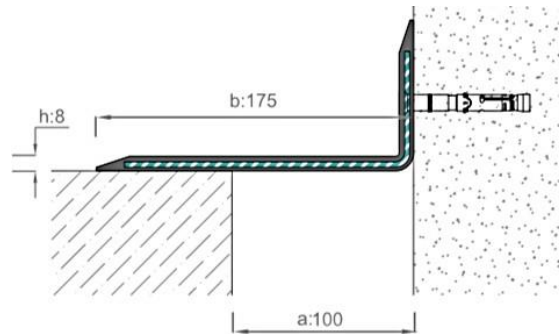

» COR_180_951

 Perfiles conjuntos de expansión
 de estacionamiento
 Car park expansion joint profiles

La serie COR 951 es una junta de expansión compuesta de caucho + acero. Aplicado al suelo y se puede utilizar como parachoques de velocidad. Montado en el suelo por anclajes de acero apropiados, con intervalos de 25 cm.

COR 951 series are rubber + steel composite expansion joint profiles. Applied to floors and can be used as a speed bumper. Assembled to the floor by appropriate steel anchors of having 25cm intervals.



REF	DESCRIPCIÓN DESCRIPTION	ANCHO CONJUNTO (a) mm JOINT WIDTH	SUPERFICIE VISIBLE (b) mm SURFACE VISIBLE	ALTURA (h) mm PROFILE HEIGHT	ST37 ESPESOR DE ACERO (mm) STEEL THICKNESS	ANCHO (s) mm TOTAL WIDTH	SUPERFICIE SURFACE	CAPACIDAD DE MOVIMIENTO MOVEMENT CAPACITY	CAPACIDAD DE CARGA LOAD CAPACITY
COR_050_951	Juntas de suelo de acero, de caucho y de acero Composite, rubber, steel floor profile	50	200	8	3	200	Goma Rubber	+50	9 Ton
COR_100_951	Juntas de suelo de acero, de caucho y de acero Composite, rubber, steel floor profile	80-100	250	8	3	250	Goma Rubber	+50/-100	9 Ton
COR_150_951	Juntas de suelo de acero, de caucho y de acero Composite, rubber, steel floor profile	120-150	300	10	4	300	Goma Rubber	+50/-150	6 Ton
COR_180_951	Juntas de suelo de acero, de caucho y de acero Composite, rubber, steel floor profile	180-200	350	12	5	350	Goma Rubber	+65/-180	3,5 Ton
COR_250_951	Juntas de suelo de acero, de caucho y de acero Composite, rubber, steel floor profile	250	400	12	6	400	Goma Rubber	+65/-250	3,5 Ton
COR_300_951	Juntas de suelo de acero, de caucho y de acero Composite, rubber, steel floor profile	300	600	15	8	600	Goma Rubber	+28mm	3,5 Ton

Junta de ampliación de pavimentos para aparcamientos
 Car park flush mounted floor expansion joint profiles

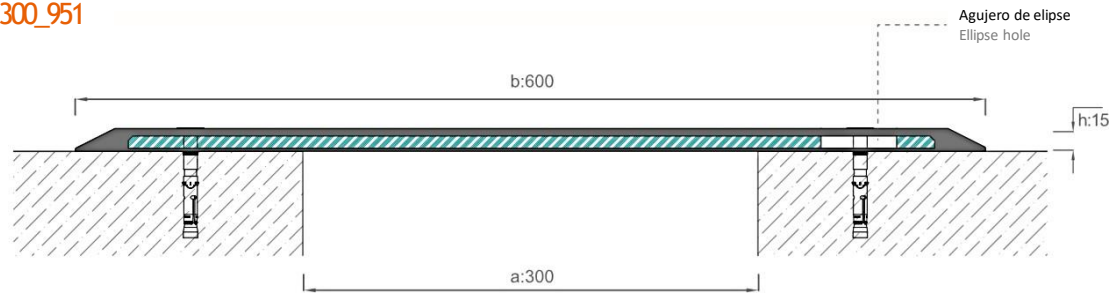

>> COR300_951

 Perfiles conjuntos de expansión
 de estacionamiento
 Car park expansion joint profiles

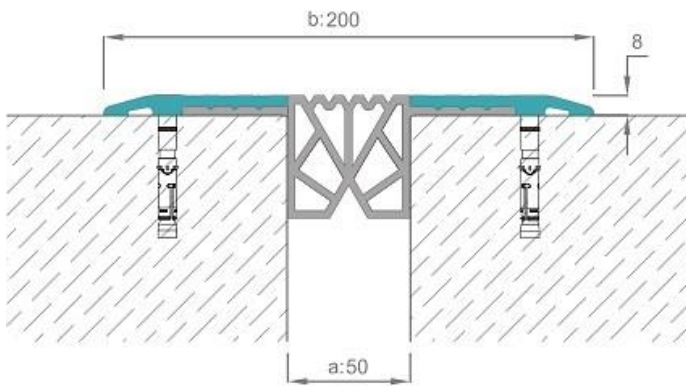
>> COR050_192

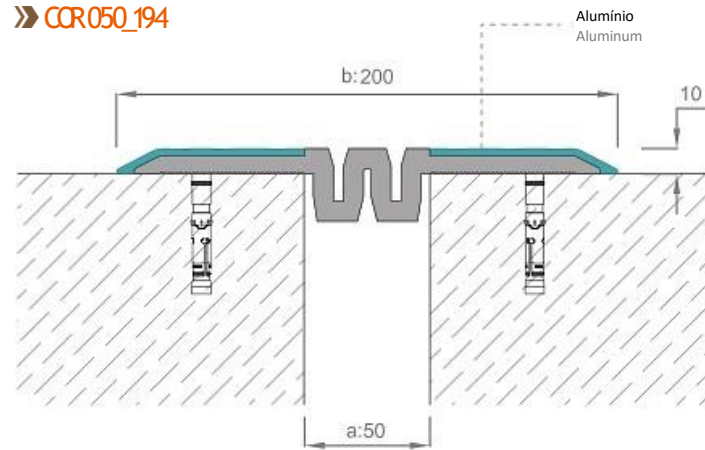

>> COR050_194



Las juntas de expansión de superficie de aluminio o acero inoxidable son adecuadas para juntas de estacionamiento de suelos montadas en superficie.

Aluminum or stainless steel top surfaced expansion joint profiles are suitable for surface mounted floor carpark profiles.



REF	DESCRIPCIÓN DESCRIPTION	ANCHO CONJUNTO (a) mm JOINT WIDTH	SUPERFICIE VISIBLE (b) mm SURFACE VISIBLE	ALTURA (h) mm PROFILE HEIGHT	ANCHO (s) mm TOTAL WIDTH	SUPERFICIE SURFACE	CAPACIDAD DE MOVIMIENTO MOVEMENT CAPACITY	CAPACIDAD DE CARGA LOAD CAPACITY
COR_050192	Junta de suelo incorporada con acabado fresado. Mill finish mounted floor profile	50	200	45	200	Acabamento ALU - TPE Mill finish ALU + TPE	± 25	9 Ton
COR_050194	Junta de suelo incorporada con acabado fresado. Mill finish mounted floor profile	50	200	20	200	Acabamento ALU + TPE Mill finish ALU + TPE	± 25	9 Ton

Juntas estancas y de dilatación de terraza
Watertight and terrace expansion joint
profiles

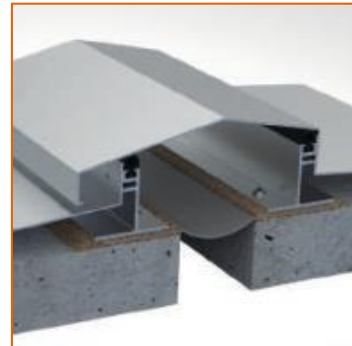
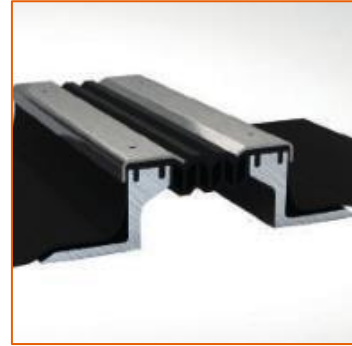
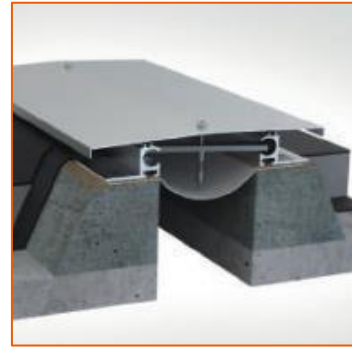

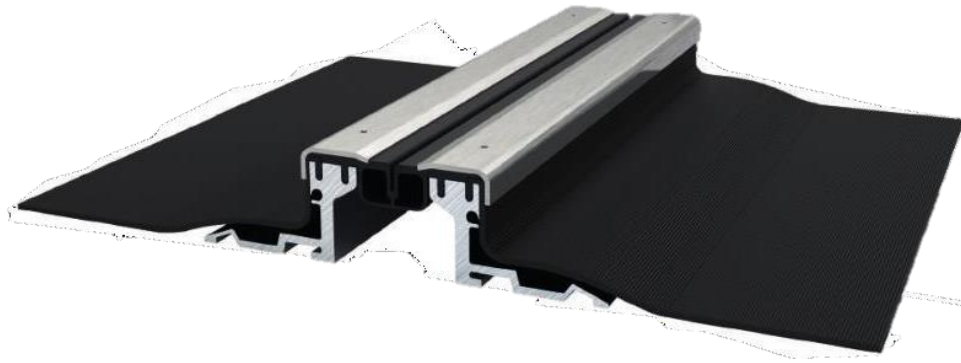
Juntas de expansión de incrustación totalmente estancas
 Flush mounted floor completely watertight expansion joint profiles

»» COR050_601

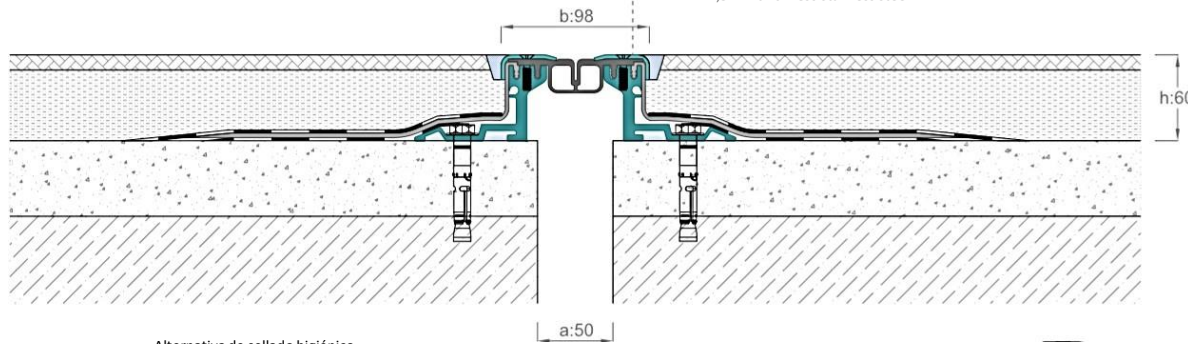
 Acero inoxidable con 2,5 mm de espesor
 2,5mm thickness stainless steel

 Juntas de expansión
 estancas
 Complete watertight
 expansion joint profiles

 Alternativa de sellado higiénico
 Hygienic gasket alternative

»» COR050A_600



»» COR050_600



»» COR050A_601



»» COR050A_602



»» COR050A_603

»» COR050_601SS

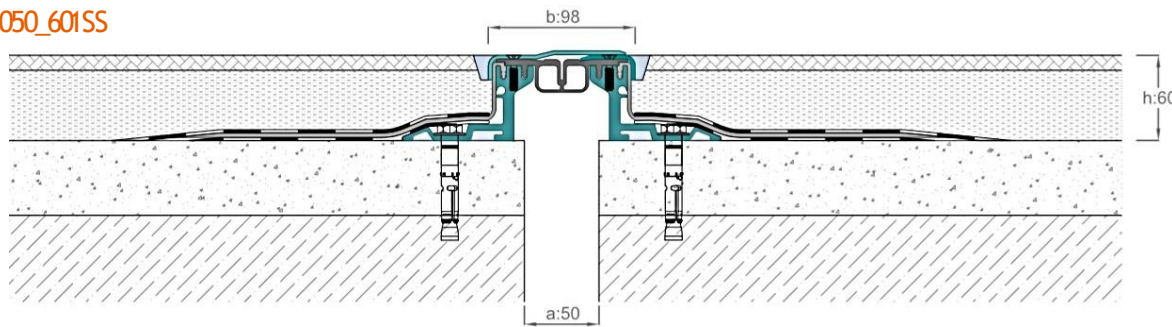
 Acero inoxidable SS 304 que se está utilizando, con membrana de betún de mezcla de goma.
 SS 304 stainless steel being used, adoptable with rubber mixture bitumen membrane.

REF	DESCRIPCIÓN DESCRIPTION	ANCHO CONJUNTO (a) mm JOINT WIDTH	SUPERFICIE VISIBLE (b) mm SURFACE VISIBLE	ALTURA (h) mm PROFILE HEIGHT	ANCHO (s) mm TOTAL WIDTH	SUPERFICIE SURFACE	CAPACIDAD DE MOVIMIENTO MOVEMENT CAPACITY	CAPACIDAD DE CARGA LOAD CAPACITY
COR_050A_600	Ideal para aplicaciones cerámicas Ideal for ceramic applications	50	97	25	580	TPV + Acero inoxidable TPV + Stainless steel	± 20	3,5 Ton
COR_050_600	Adecuado para granito, mármol, hormigón, etc. Suitable for granite, marble, concrete, etc.	50	98	50	560	TPV + Acero inoxidable TPV + Stainless steel	± 20	15 Ton 6 Ton
COR_050_600 SS	Adecuado para granito, mármol con superficie superior en acero inoxidable Suitable for granite, marble with stainless steel top surface	50	98	50	560	Acero inoxidable Stainless steel	± 20	15 Ton 6 Ton
COR_050_601	Adecuado para granito, mármol, hormigón, etc. Suitable for granite, marble, concrete, etc.	50	98	60	540	TPV + Acero inoxidable TPV + Stainless steel	± 20	15 Ton 6 Ton
COR_050_602	Adecuado para granito, mármol, hormigón, etc. Suitable for granite, marble, concrete, etc.	50	98	70	520	TPV + Acero inoxidable TPV + Stainless steel	± 20	15 Ton 6 Ton
COR_050_603	Adecuado para granito, mármol, hormigón, etc. Suitable for granite, marble, concrete, etc.	50	98	100	460	TPV + Acero inoxidable TPV + Stainless steel	± 20	15 Ton 6 Ton

Juntas de expansión de incrustación totalmente estancas
 Flush mounted floor completely watertight expansion joint profiles



Juntas de expansión
 estancas
 Complete watertight
 expansion joint profiles

» CCR050_601- K1

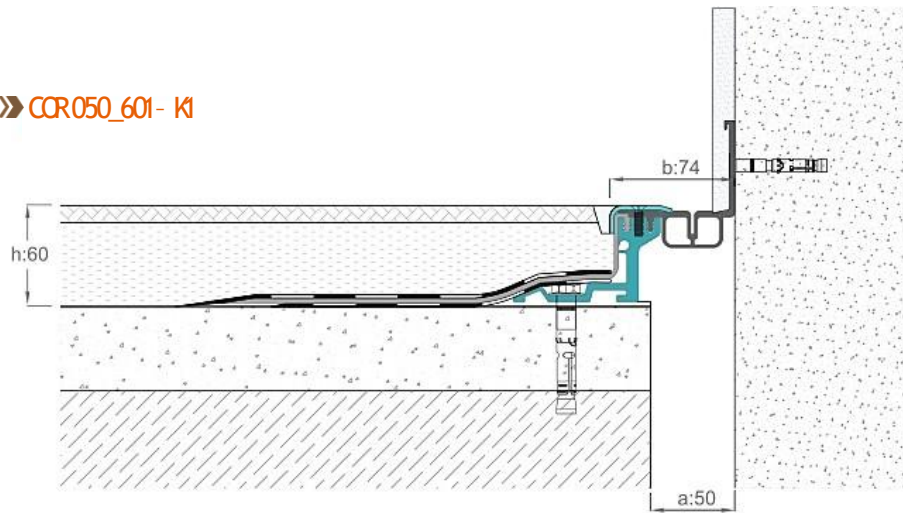

» CCR050_601- K2

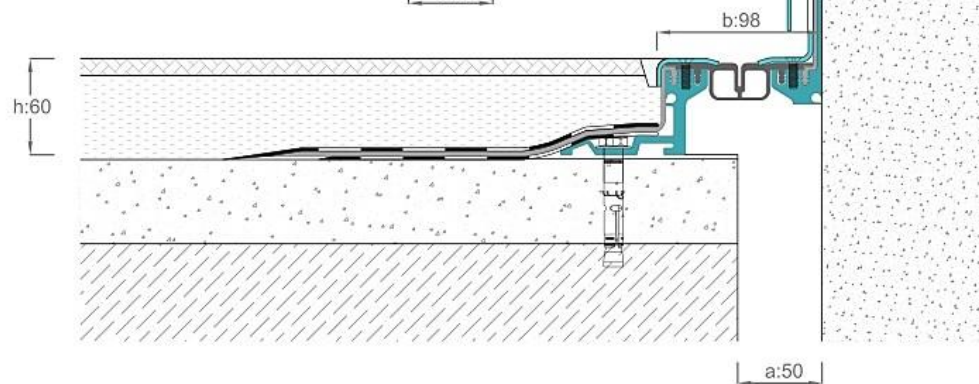

Las juntas de expansión de lado a piso termoplástica están compuestas de aluminio y acero inoxidable (SS304). Las juntas de expansión impermeables son totalmente higiénicas y completan el suelo, están conectadas a materiales aislantes aletas laterales y se utilizan en zonas húmedas y terrazas. Juntas producidas en longitudes de 3 metros y juntas en 15 metros por rodillos.

Floor to floor thermoplastic side winged expansion joint profiles are composite of aluminum and stainless steel (SS304). Materials hygienic and complete watertight floor expansion joint profiles are connected to isolation materials by side wings and used in wet areas and terraces. Profiles produced in 3 meters lengths and gaskets in 15 meters by rolls.



Juntas de expansión de incrustación totalmente estancas
 Flush mounted floor completely watertight expansion joint profiles

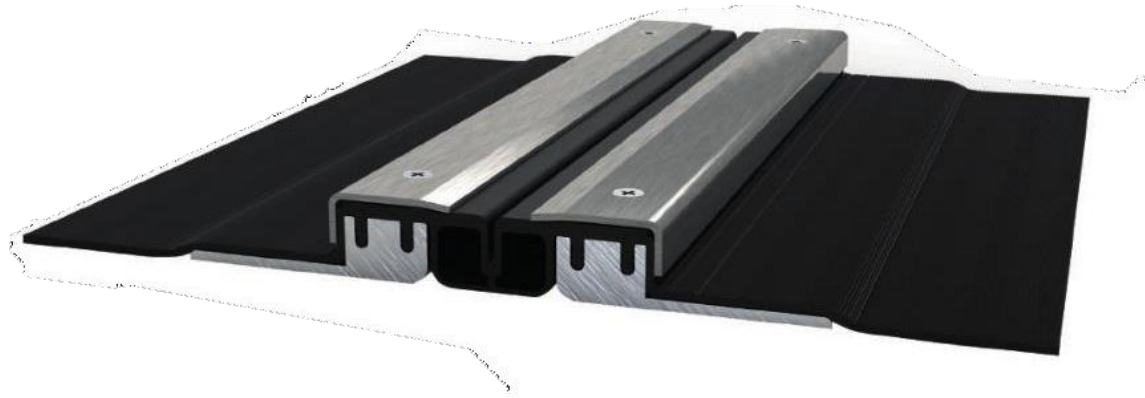

» CCR050_600- A

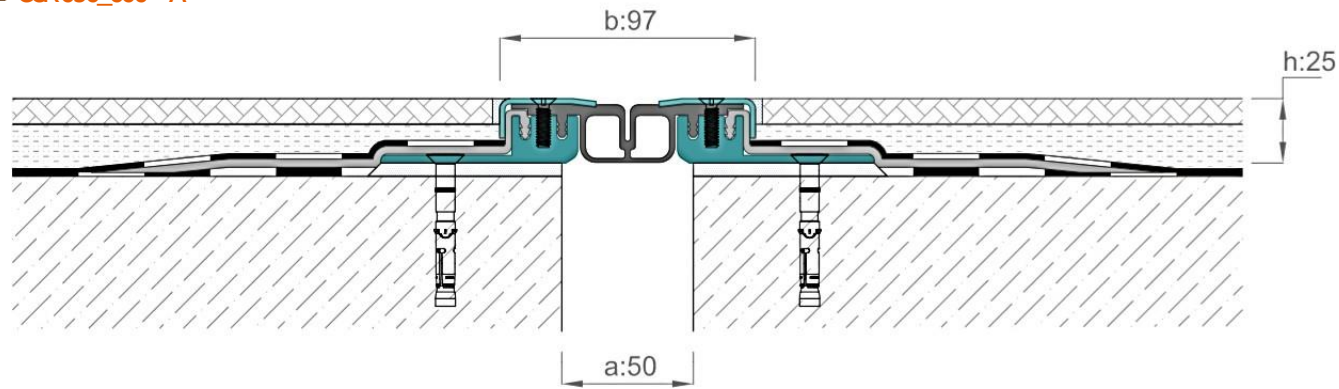

Juntas de expansión
 estancas
 Complete watertight
 expansion joint profiles

» CCR050_600- A2

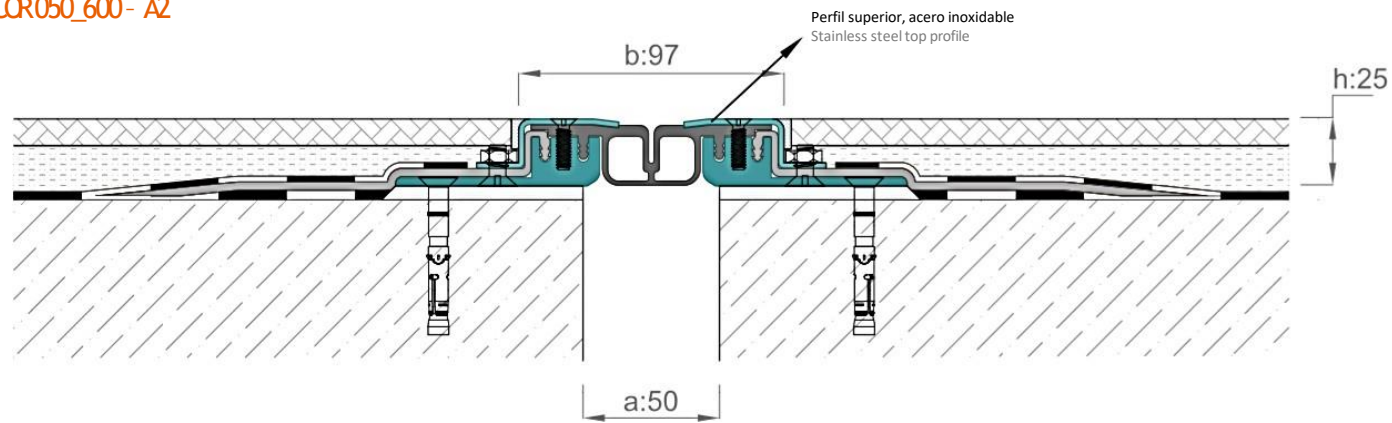

Estas juntas de expansión son de montaje incorporado y se insertan en TPE se utilizan para áreas húmedas y terrazas con baja altura de cobertura.
 These flush mounted and TPE inserted expansion joint profiles used for wet areas and terraces with low covering height.



Juntas de expansión de incrustación totalmente estancas
 Flush mounted floor completely watertight expansion joint profiles



Juntas de expansión estancas
 Complete watertight expansion joint profiles

» CCR050_600- AK1

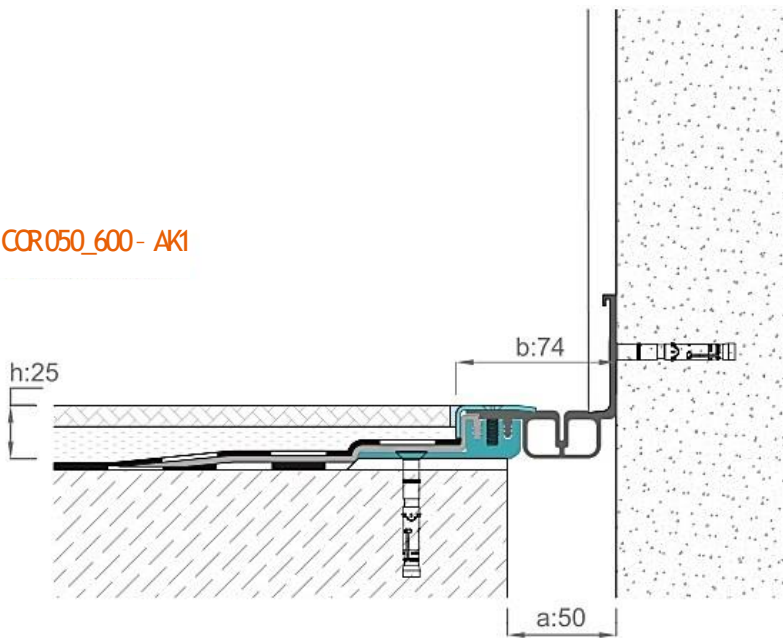

» CCR050_600- AK2

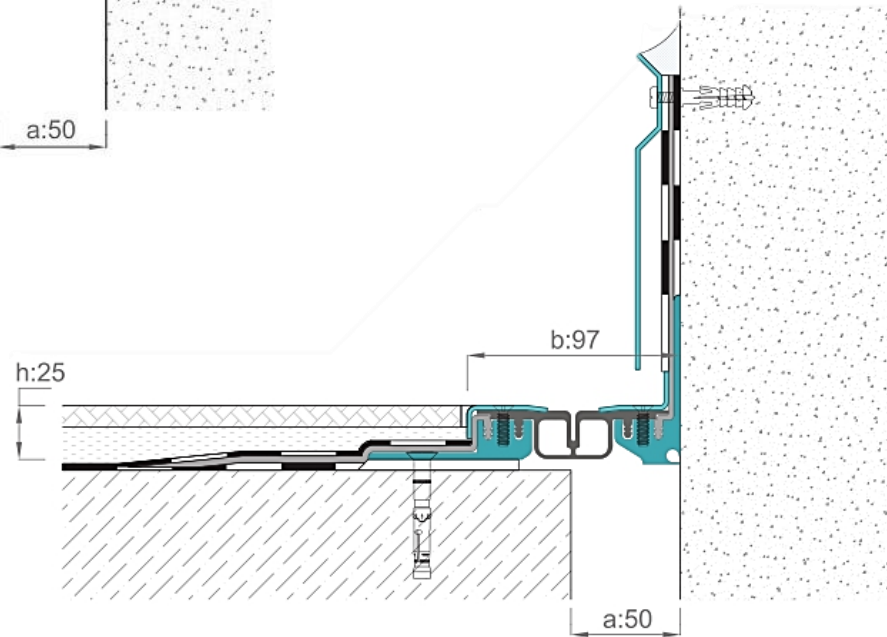

Juntas de expansión de incrustación totalmente estancas
 Flush mounted floor completely watertight expansion joint profiles



» COR 100_600

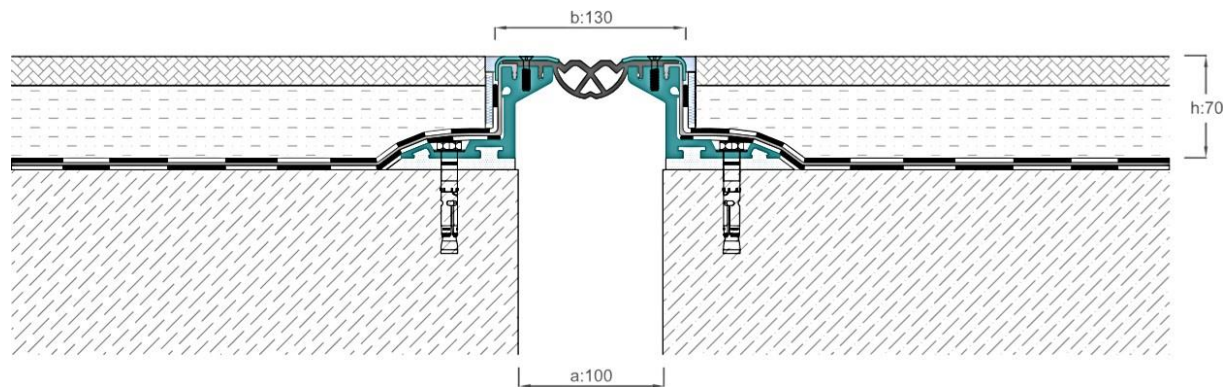

Juntas de expansión estancas
 Complete watertight expansion joint profiles

» COR 100_600 SS

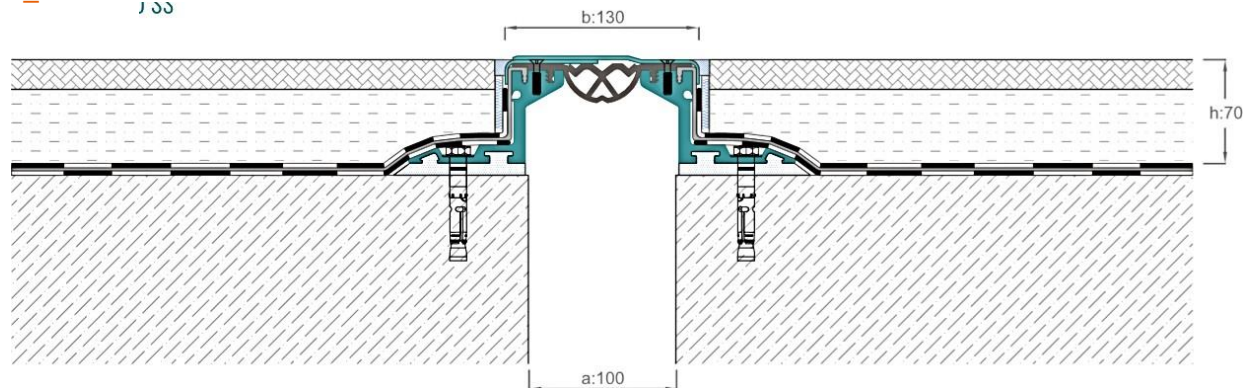

Se utilizan juntas de expansión de acero inoxidable, económicas y de superficie integradas en la superficie para holguras en juntas de 100mm. Además es adecuado con membrana de betún de mezcla de goma.

Economic Stainless-steel top surface flush mounted expansion joint profiles are used for 100mm joint gaps. Additionally. Suitable with rubber mixture bitumen membrane.

REF	DESCRIPCIÓN DESCRIPTION	ANCHO CONJUNTO (a) mm JOINT WIDTH	SUPERFICIE VISIBLE (b) mm SURFACE VISIBLE	ALTURA (h) mm PROFILE HEIGHT	ANCHO (s) mm TOTAL WIDTH	SUPERFICIE SURFACE	CAPACIDAD DE MOVIMIENTO MOVEMENT CAPACITY	CAPACIDAD DE CARGA LOAD CAPACITY
COR_100_600	Adecuado para granito, mármol, hormigón, etc. Suitable for granite, marble, concrete, etc.	100	130	70	580	TPV + Acero inoxidable TPV + Stainless steel	± 20	9 Ton 3.5 Ton
COR_100_600 SS	Adecuado para granito, mármol con superficie superior en acero inoxidable Suitable for granite, marble with stainless steel top surface	100	130	70	580	Acero inoxidable Stainless steel	± 20	9 Ton 3.5 Ton

Juntas de expansión de incrustación totalmente estancas
Flush mounted floor completely watertight expansion joint profiles



» COR 100_600

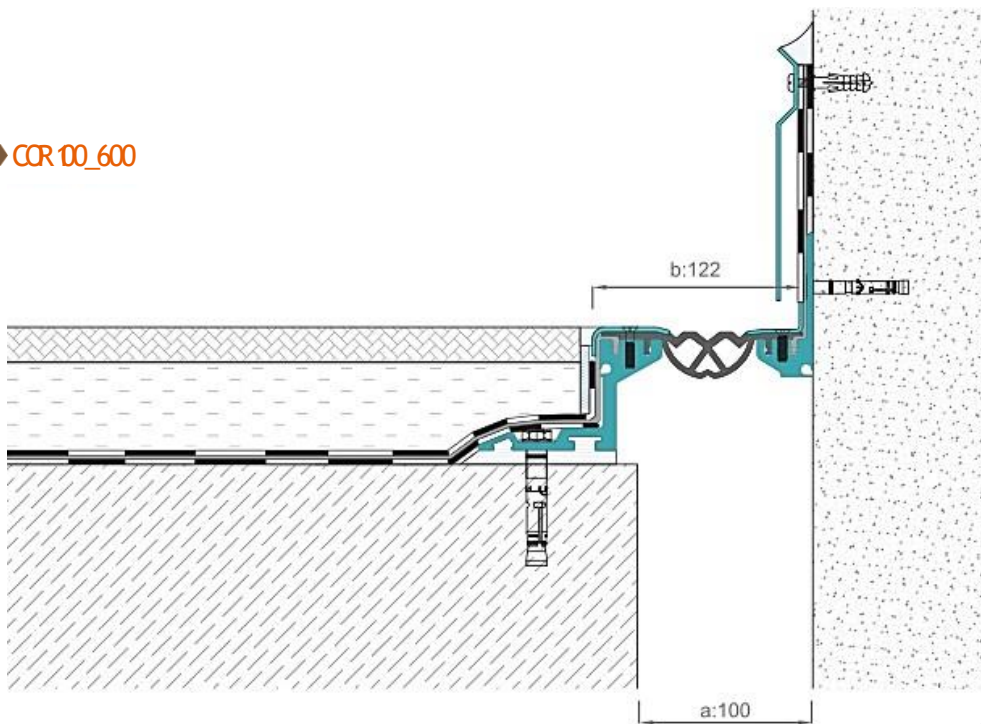

» COR 100_600 SSK

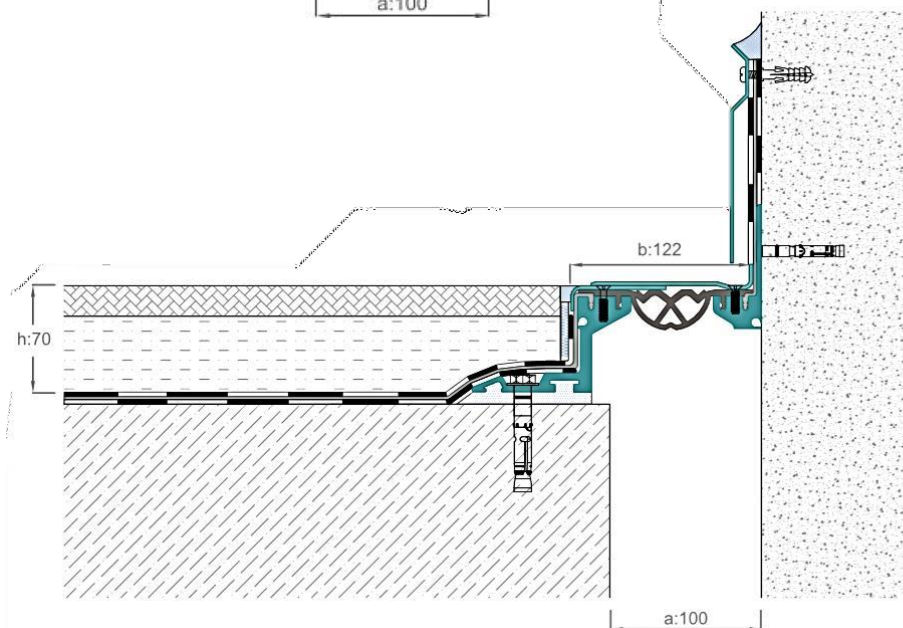

Juntas de expansión
estancas
Complete watertight
expansion joint profiles

Juntas de expansión de incrustación totalmente estancas
 Flush mounted floor completely watertight expansion joint profiles

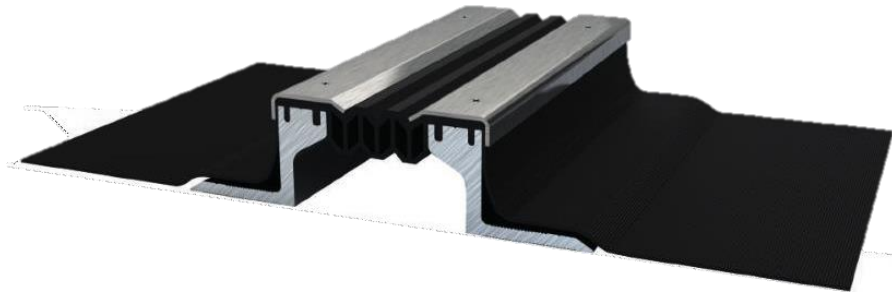

» COR 00_600

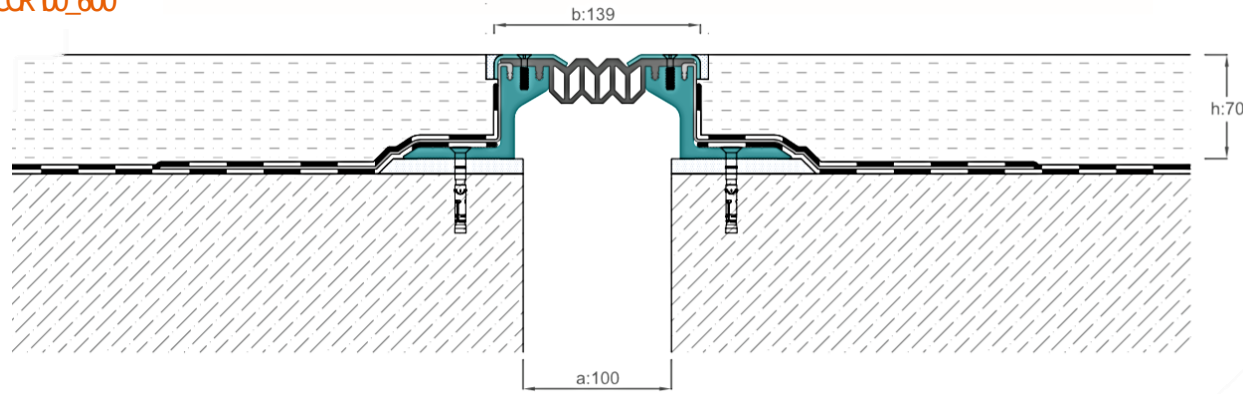

Juntas de expansión
 estancas
 Complete watertight
 expansion joint profiles

» COR 01_600 SS

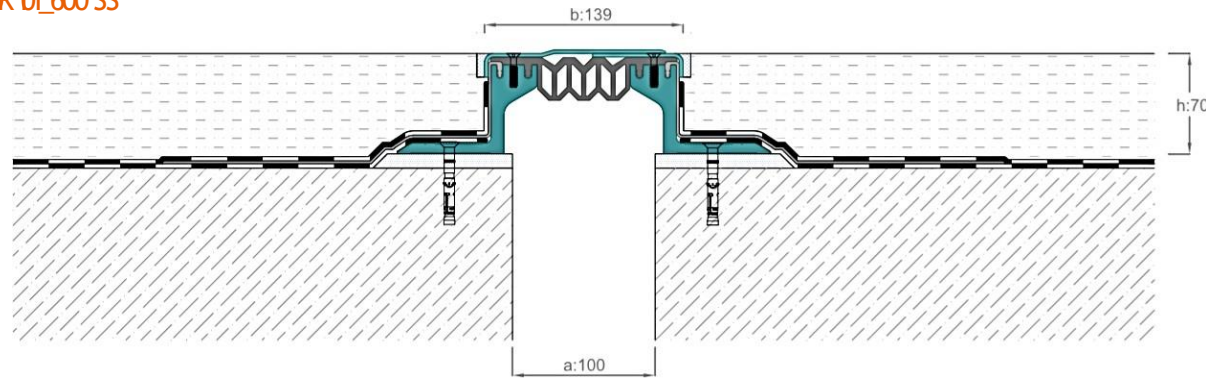

Las juntas de expansión insertadas en TPE y completamente estancas tienen una alta capacidad de manipulación. El daño mecánico (tornillos, etc.) se evita mediante la superficie superior higiénica y el inserto TPE. También está disponible la opción alternativa de la junta completa de acero inoxidable.

TPE inserted and completely watertight expansion joint profiles have the high capacity to move. Mechanical damages (screws etc.) are prevented by hygienic top surface and TPE insert. The alternative complete stainless-steel option is also available.



REF	DESCRIPCIÓN DESCRIPTION	ANCHO CONJUNTO (a) mm JOINT WIDTH	SUPERFICIE VISIBLE (b) mm SURFACE VISIBLE	ALTURA (h) mm PROFILE HEIGHT	ANCHO (s) mm TOTAL WIDTH	SUPERFICIE SURFACE	CAPACIDAD DE MOVIMIENTO MOVEMENT CAPACITY	CAPACIDAD DE CARGA LOAD CAPACITY
COR_101 600	Adecuado para granito, mármol, hormigón, etc. Suitable for granite, marble, concrete, etc.	100	139	70	590	TPV + Acero inoxidable TPV + Stainless steel	± 30	15 Ton 6 Ton
COR_101 600 SS	Adecuado para granito, mármol con superficie superior en acero inoxidable Suitable for granite, marble with stainless steel top surface	100	139	70	590	Acero inoxidable Stainless steel	± 30	15 Ton 6 Ton
COR_150 600	Adecuado para granito, mármol, hormigón, etc. Suitable for granite, marble, concrete, etc.	150	184	70	630	TPV + Acero inoxidable TPV + Stainless steel	± 50	15 Ton 6 Ton
COR_150 600 SS	Adecuado para granito, mármol con superficie superior en acero inoxidable Suitable for granite, marble with stainless steel top surface	150	184	70	630	Acero inoxidable Stainless steel	± 50	15 Ton 6 Ton
COR_200 600	Adecuado para granito, mármol, hormigón, etc. Suitable for granite, marble, concrete, etc.	200	234	70	680	TPV + Acero inoxidable TPV + Stainless steel	± 50	9 Ton 3,5 Ton
COR_200 600 SS	Adecuado para granito, mármol con superficie superior en acero inoxidable Suitable for granite, marble with stainless steel top surface	200	234	70	680	Acero inoxidable Stainless steel	± 50	9 Ton 3,5 Ton

Juntas de expansión de incrustación totalmente estancas
 Flush mounted floor completely watertight expansion joint profiles



Juntas de expansión
 estancas
 Complete watertight
 expansion joint profiles

» CCR 100_600

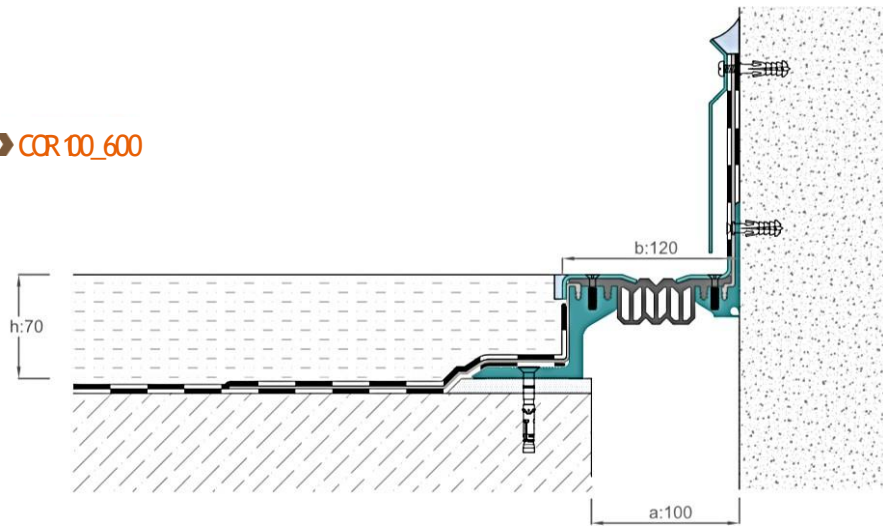

» CCR 100_600

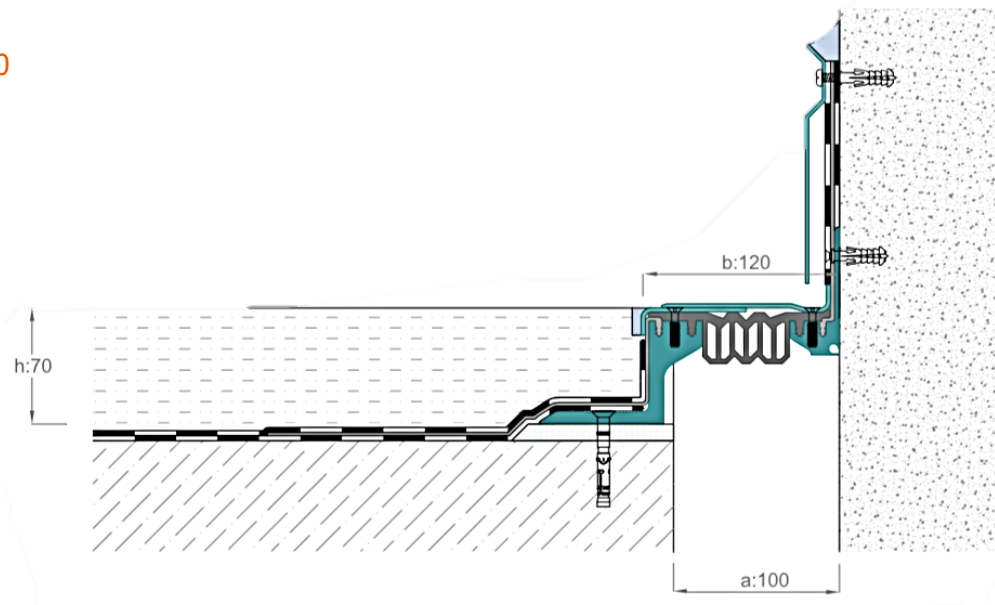

Juntas de expansión de incrustación totalmente estancas
 Flush mounted floor completely watertight expansion joint profiles

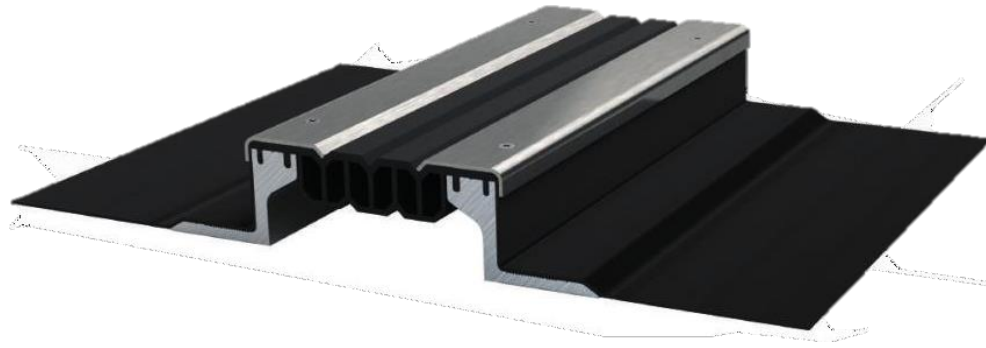

» CCR 60_600

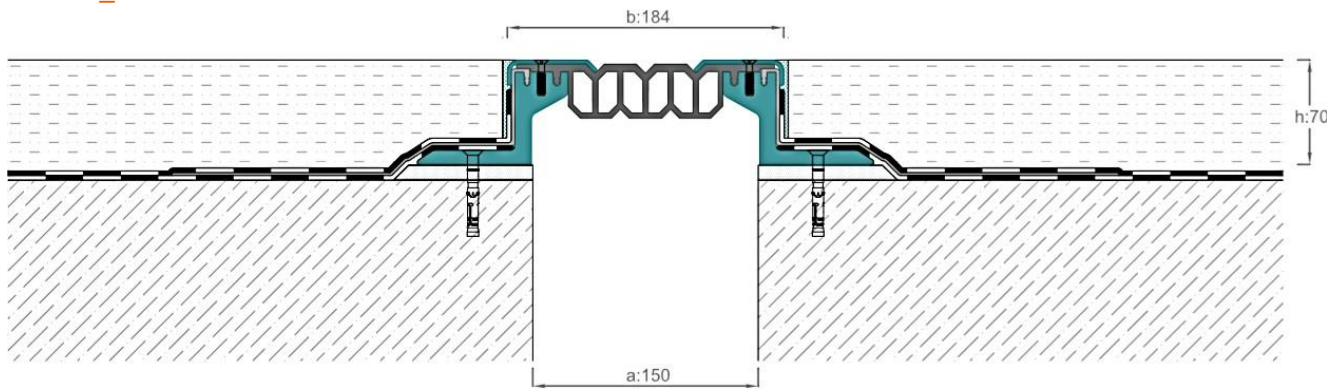

Juntas de expansión
 estancas
 Complete watertight
 expansion joint profiles

» CCR 60_600SS

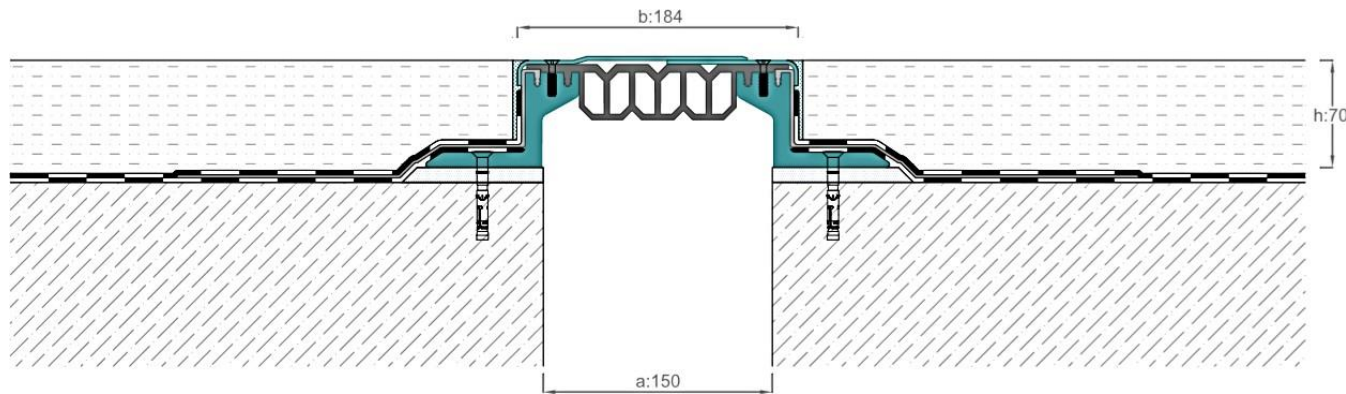

Las juntas montadas en el suelo y las juntas de expansión totalmente estancas son adecuadas para intervalos de 15 cm y resistentes a cargas pesadas, con un inserto TPE especial en el centro. Se pueden utilizar cómodamente en áreas abiertas y cerradas. La conexión de los detalles T y L también está disponible.

Flush mounted floor and completely watertight expansion joint profiles are suitable for 15cm gaps and resistant to heavy loads by having special TPE insert in the middle. They can comfortably be used in open and closed areas. Connection of T and L details are also available.



Juntas de expansión de incrustación totalmente estancas
Flush mounted floor completely watertight expansion joint profiles



Juntas de expansión
estancas
Complete watertight
expansion joint profiles

» CCR 60_600K

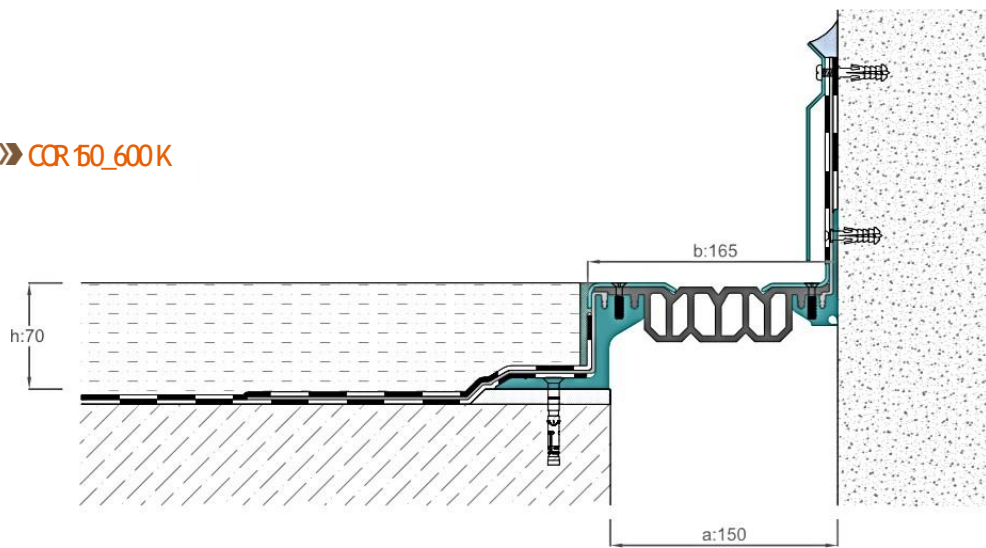

» CCR 60_600SSK

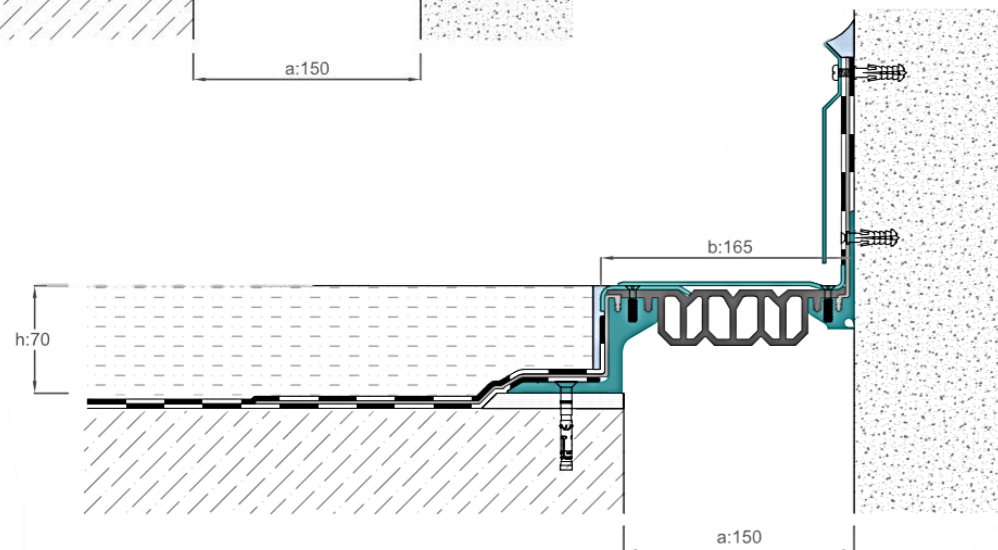

Los bits adicionales se pueden fundir utilizando sólo el suministro de aire caliente y no requiere ninguna otra fuente adicional.
Additional bits can be melted by only using hot air supply and does not require any other extra source

Bandas de juntas de expansión termoplástica
Thermoplastic expansion joints bands

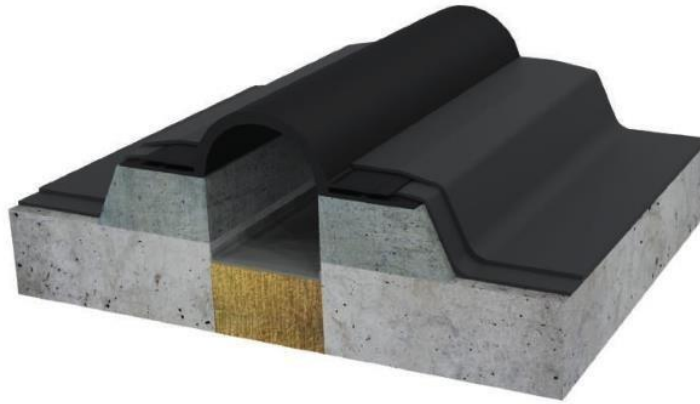

» CCR 01_500

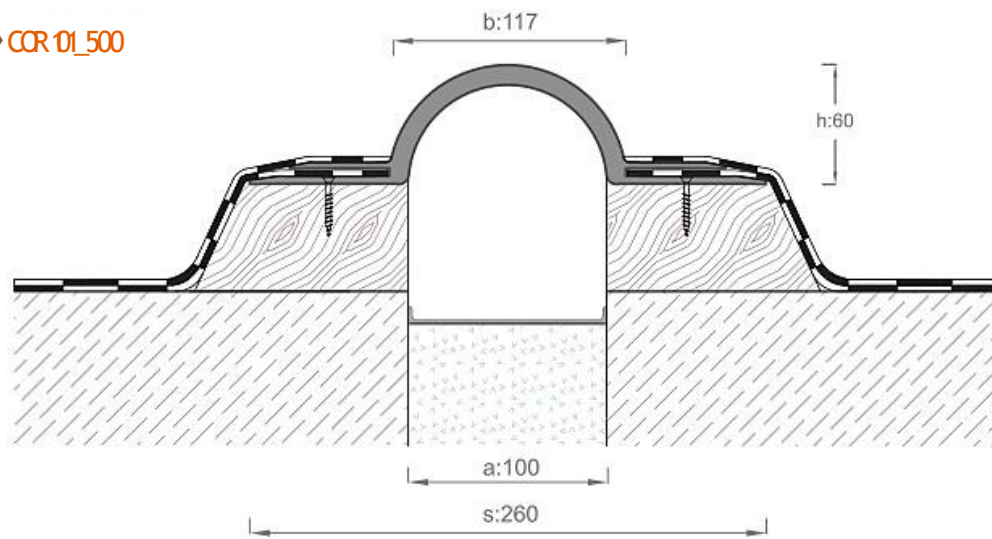

Juntas de expansión
estancas
Complete watertight
expansion joint profiles

» CCR 01_500
Detalle de la esquina / Corner detail

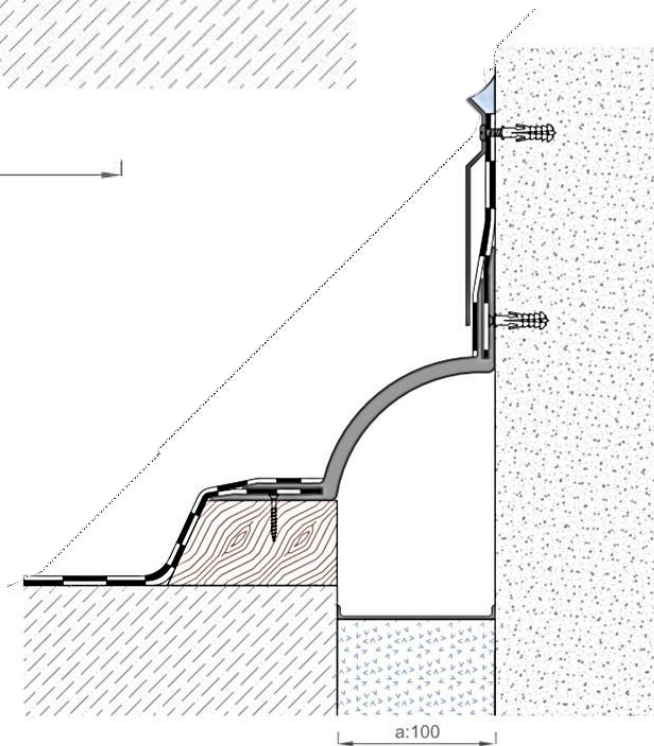

Las bandas termoplásticas de la terraza omega con 10 mm de espesor son resistentes a impactos y riesgos de arañazos con su parte central fuerte. producido en longitudes de 15 metros.
10mm thick omega terrace thermoplastic bands are resistant to impacts and tearing risks with its strong middle part. produced in 15 meter lengths.



Bandas de juntas de expansión termoplástica y bandas estancas de PVC
Thermoplastic expansion joints bands and PVC watertight bands.



» CCR030_500

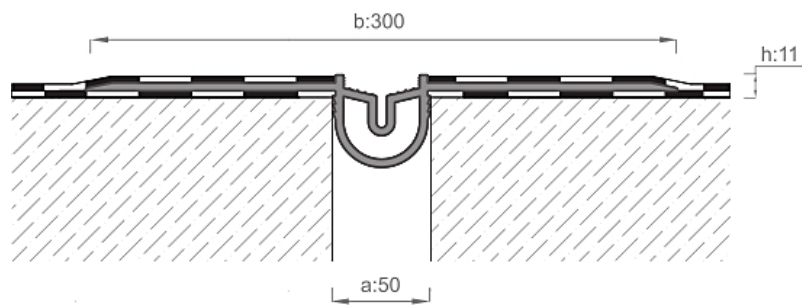

Junta de expansión estanca
Complete watertight expansion joint profiles

» CCR20-5-I

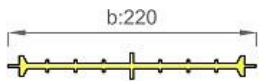

» CCR20-3/4-AK



» CCR20-5-A

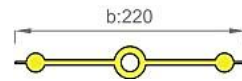

» CCR25-4-M

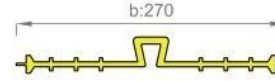

» CCR25-5-O

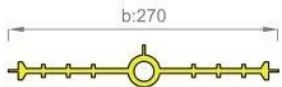

» CCR25-5-DO



» CCR100-50-T

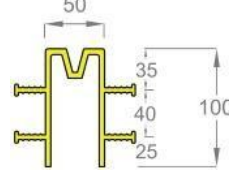

» CCR140-50-T

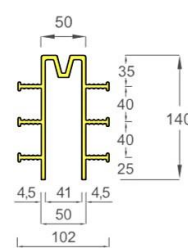

Nuestras bandas estancas de diferentes tipos y dimensiones son adecuadas para los estándares internacionales. Se utiliza en la base para la pared de contención, cimentación para la cimentación y muro de contención para muro de contención. Entregado 25 metros de largo en rollo.

Our different type and dimensioned watertight bands are suitable for international standards. Utilized in foundation to retaining wall, foundation to foundation and retaining wall to retaining wall. Delivered in 25 meters length as a roll.



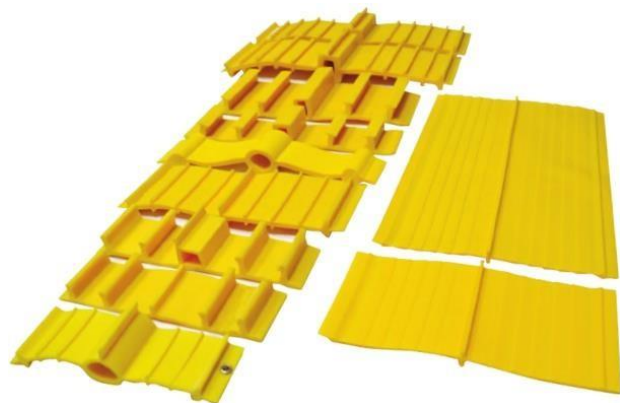

Finalidad de uso: por diversas razones (asentamientos, terremotos, etc.), muchas estructuras se enfrentan a huecos horizontales o verticales. Para mantener la estanqueidad en estos huecos, se aplican bandas de PVC impermeables

Purpose of use: for several reasons (settlement, earthquake etc.) many structures face with horizontal or vertical gaps. To maintain water tightness in these gaps PVC watertight bands are applied.

Material: extruido manteniendo la temperatura y presión adecuadas utilizando la mezcla de resina de cloruro de polivinilo (PVC), varios catalizadores, estabilizador, antioxidantes, manchas, endurecedor y plastificante.

Material: Extruded by maintaining appropriate temperature and pressure using mixture of polyvinyl chloride (PVC) resin, various catalysts, stabilizer, antioxidants, stain, hardener and plasticizer.

» Zonas de aplicación / Application areas

Centrales hidráulicas, puentes, construcciones subterráneas, viaductos, muros de contención, suelos y bases sentados en el suelo, plantas hidráulicas, aguas subterráneas por debajo del nivel de las aguas subterráneas, drenaje, embalses, instalaciones de tratamiento de agua, piscinas, lagos / estanques, composiciones de cortinas, construcciones industriales.

Hydraulic power plants, bridges, underground constructions, viaducts, retaining walls, flooring and bases sitting on the ground, hydraulic power stations, underground water below the groundwater level, drainage, water reservoirs, water treatment facilities, swimming pools, waterfalls, curtain compositions, industrial constructions.

» Especificaciones técnicas / Technical specification

<i>Resistencia a la tracción / Tensile strength</i>	<i>Valor medio Average value</i>	<i>Min. 14</i>	<i>N/mm2</i>
	<i>El valor más bajo The smallest value</i>	<i>Min. 12</i>	<i>N/mm2</i>
<i>Capacidad totalmente igual/ stretching capacity</i>	<i>Valor medio Average value</i>	<i>Min. 225</i>	<i>%</i>
	<i>El valor más pequeño The smallest value</i>	<i>Min.200</i>	<i>%</i>
<i>Introduzca un grado de dureza del durómetro de costa Type a shore durometer hardness grade</i>		<i>75+5</i>	<i>Costa "A" Shore "A"</i>
<i>Volumen de masa unitario (densidad) Unit volume of mass (density)</i>		<i>1.27+0.04</i>	<i>g/cm3</i>
<i>Proporción de absorción de masa en agua Mass to water absorption ratio</i>		<i>Max. 1.5</i>	<i>%</i>
<i>Relación masa/gris de sutura Mass to ash ratio suture</i>		<i>Max. 5.0 (m/m)</i>	<i>%</i>

Juntas de expansión
 estanques
 Complete watertight
 expansion joint profiles

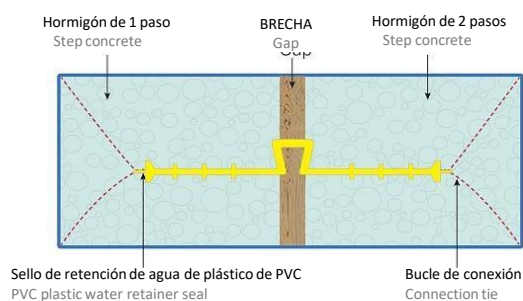

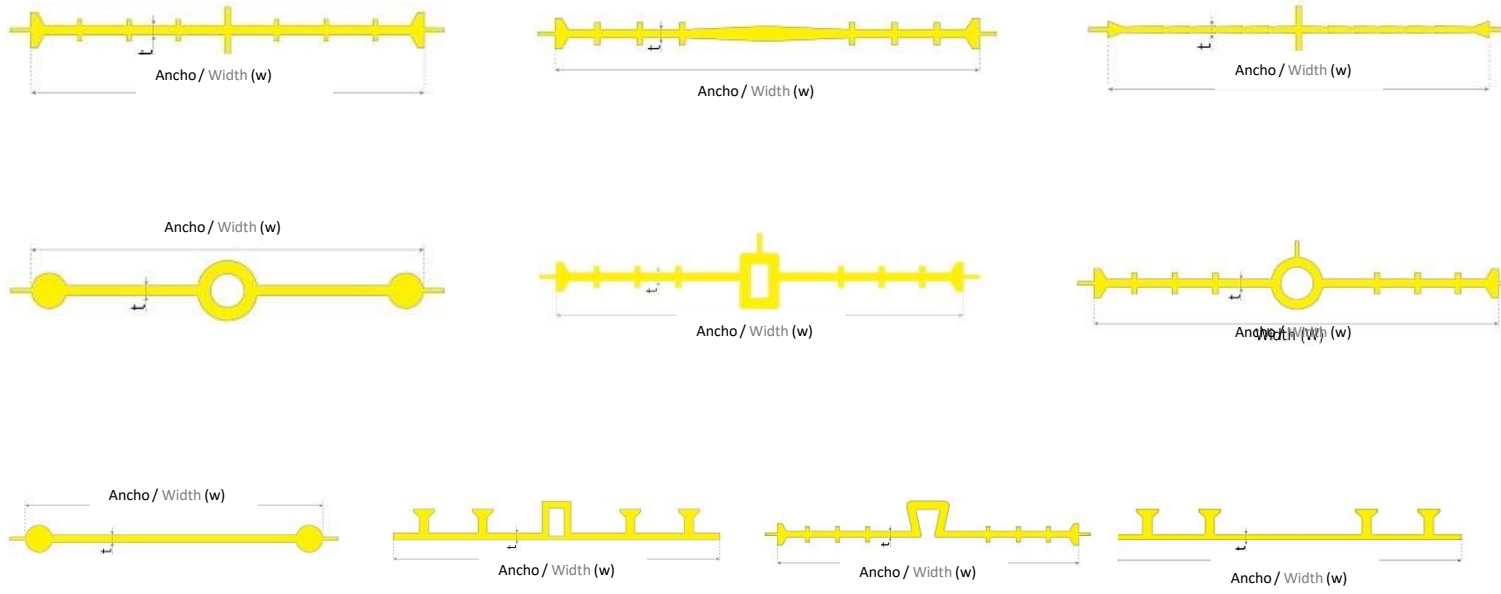

Junta de expansión
estancas
Complete watertight
expansion joint profiles

Tipo / Type	Ancho / Width	15	15	15	15	15	15	20	20	23	23	25	25	25	30	30	30	30	35	35	40	40	50	50
A	Grueso / Thickness	4	5	6	7	8	10	5	7	7	10	6	8	10	6	7	9	10	8	10	10	12	10	12
B	Ancho / Width	10	10	15	15	15	15	20	20	20	23	25	25	25	25	30	30	30	35	35	35	40	40	
	Grueso / Thickness	4	6	5	7	8	10	6	8	10	10	5	6	8	10	6	8	10	6	8	10	10	12	
I	Ancho / Width	10	10	10	15	15	15	20	20	20	20	25	25	25	25	30	30	30	30	30	30	32	35	32
	Grueso / Thickness	3	4	5	3	4	5	4	5	6	8	4	5	6	8	4	5	6	7	8	6	8	10	
OL	Ancho / Width	20	20	20	25	25	25	30	30	30	30	32	32	32	35	35	35	40	40	40	50	50	50	
	Grueso / Thickness	5	6	7	5	6	7	8	7	8	9	10	5	8	10	8	9	10	8	10	12	8	10	12
M	Ancho / Width	15	15	15	20	20	20	25	25	25	25	30	30	30	32	32	32	32	35	35	35	35	40	40
	Grueso / Thickness	3	4	5	4	5	6	8	4	5	6	8	10	5	6	7	6	8	10	6	7	8	10	8
V	Ancho / Width	10	10	10	15	15	15	20	20	20	20	25	25	25	25	30	30	30	30	30	30	35	35	35
	Grueso / Thickness	3	4	5	3	4	5	4	5	6	7	8	4	5	6	8	4	5	6	8	6	8	10	
DT	Ancho / Width	15	15	20	20	20	25	25	25	25	30	30	30	35	35	35	40	40	40					
	Grueso / Thickness	3	5	4	6	8	4	5	6	8	4	6	8	4	6	8	6	8	10					
DO	Ancho / Width	15	15	20	20	20	25	25	25	25	30	30	30	35	35	35	40	40	40					
	Grueso / Thickness	3	5	4	6	8	4	5	6	8	4	6	8	4	6	8	6	8	10					
DI	Ancho / Width	15	15	20	20	20	25	25	25	30	30	30	35	35	35	40	40	40						
	Grueso / Thickness	3	4	5	6	8	4	6	8	4	6	8	4	6	8	6	8	10						
O	Ancho / Width	15	15	15	20	20	20	22	22	22	26	26	26	30	30	30	32	32	32					
	Grueso / Thickness	3	4	5	3	4	5	4	5	6	4	5	6	4	5	6	4	5	6					
AK	Ancho / Width	15	15	15	20	20	20	24	24	24	24													
	Grueso / Thickness	3	4	5	3	4	5	3	4	5	6													

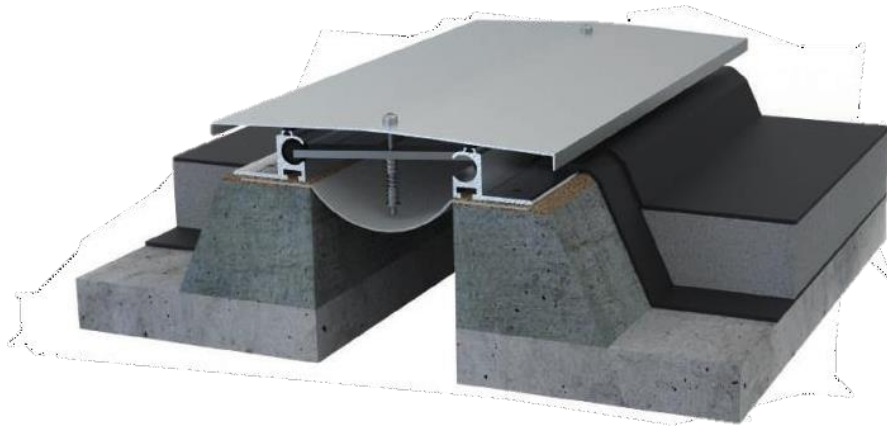
Bandas de juntas de dilatação termoplásticas e faixas estanques de PVC
 Thermoplastic expansion joints bands and PVC watertight bands

» COR 100_605

» COR 100K_605

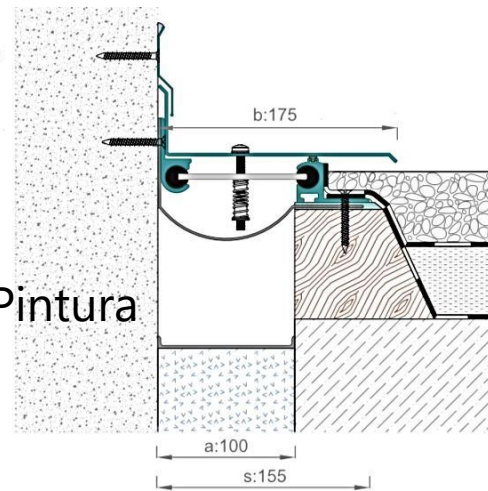
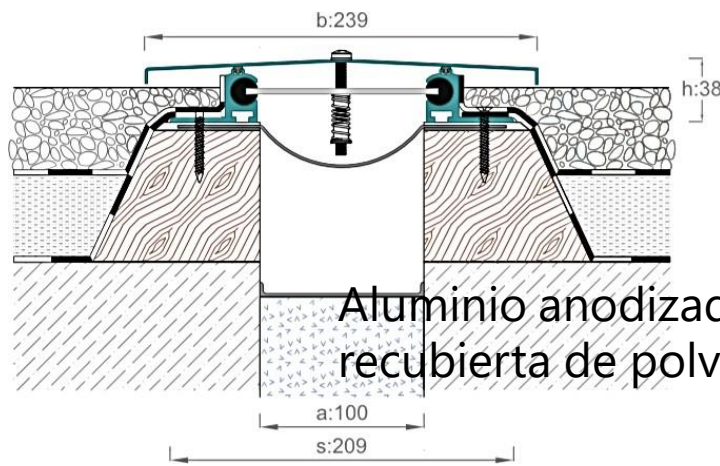
 Aluminio anodizado / Pintura
 recubierta de polvo

 Juntas de expansión
 estanques
 Complete watertight
 expansion joint profiles

Las juntas de expansión de terraza se utilizan como protectores y aislantes en terrazas abiertas. Aplicado con cuñas de madera absorbidas betún o dilatación de cemento. Los perfiles H se montan en lugares adicionales para una estanqueidad completa.

Coping type terrace expansion joint profiles are used as protectors and isolators in opened terraces. Applied with bitumen absorbed wooden wedges or dilatation concrete. H profiles are fitted in additional places to achieve complete water tightness.



REF	DESCRIPCIÓN DESCRIPTION	ANCHO CONJUNTO (a) mm JOINT WIDTH	SUPERFICIE VISIBLE (b) mm SURFACE VISIBLE	ALTURA (h) mm PROFILE HEIGHT	ANCHO (s) mm TOTAL WIDTH	SUPERFICIE SURFACE	CAPACIDAD DE MOVIMIENTO (mm) MOVEMENT CAPACITY
COR_050_605	juntas de recubrimiento para aplicaciones de terraza Coping profiles for terrace applications	50	189	38	189	Aluminio anodizado / Pintura recubierta de polvo Anodized aluminum / Powder coated paint	± 25
COR_100_605	juntas de recubrimiento para aplicaciones de terraza Coping profiles for terrace applications	100	239	38	239	Aluminio anodizado / Pintura recubierta de polvo Anodized aluminum / Powder coated paint	± 50
COR_150_605	juntas de recubrimiento para aplicaciones de terraza Coping profiles for terrace applications	150	289	38	289	Aluminio anodizado / Pintura recubierta de polvo Anodized aluminum / Powder coated paint	± 75
COR_200_605	juntas de recubrimiento para aplicaciones de terraza Coping profiles for terrace applications	200	339	38	339	Aluminio anodizado / Pintura recubierta de polvo Anodized aluminum / Powder coated paint	± 100
COR_250_605	juntas de recubrimiento para aplicaciones de terraza Coping profiles for terrace applications	250	389	38	389	Aluminio anodizado / Pintura recubierta de polvo Anodized aluminum / Powder coated paint	± 100
COR_300_605	juntas de recubrimiento para aplicaciones de terraza Coping profiles for terrace applications	300	439	38	439	Aluminio anodizado / Pintura recubierta de polvo Anodized aluminum / Powder coated paint	± 100

Juntas de expansión de terraza
Terrace expansion joint profiles



» CCR 01_605

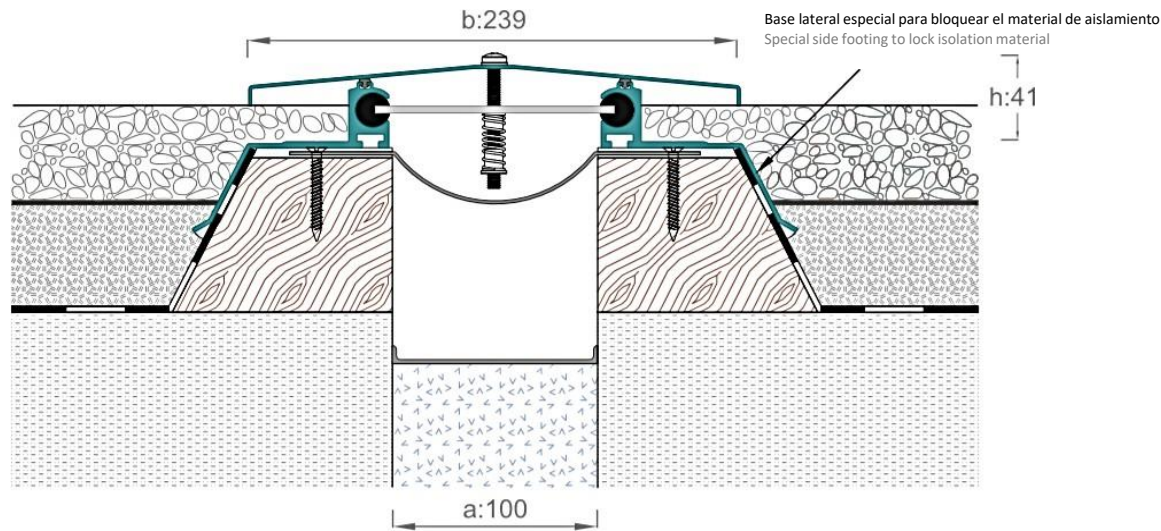

Juntas de expansión
estancas
Complete watertight
expansion joint profiles

» CCR 01K_605

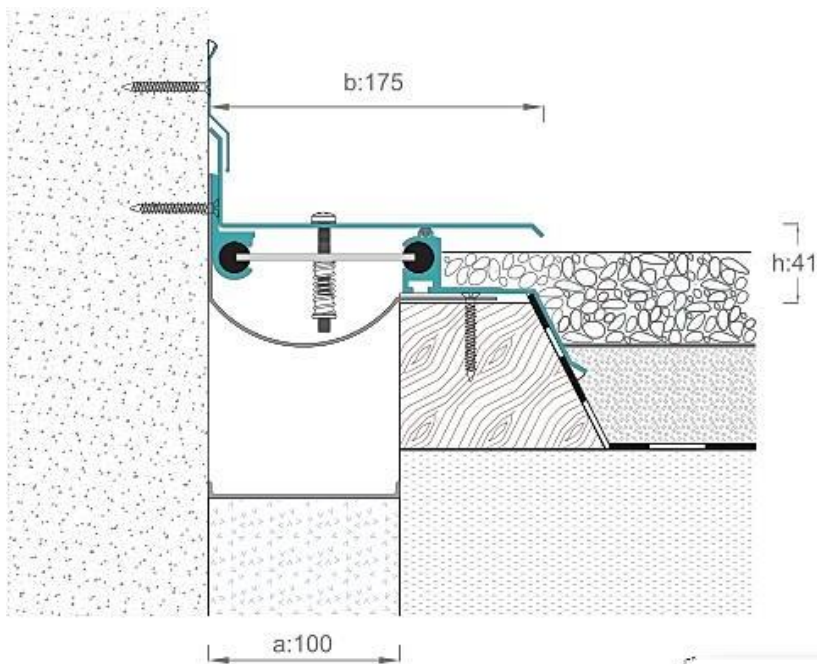

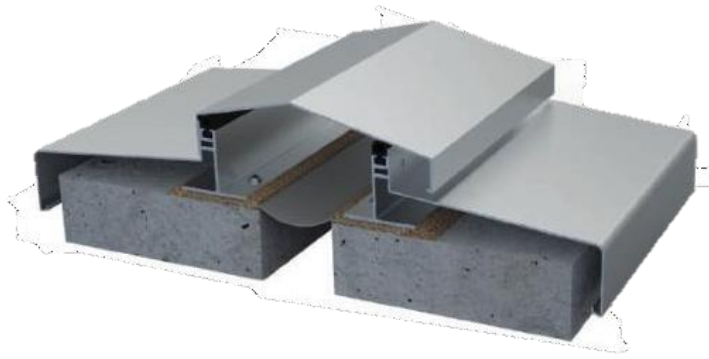
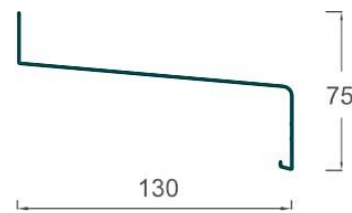
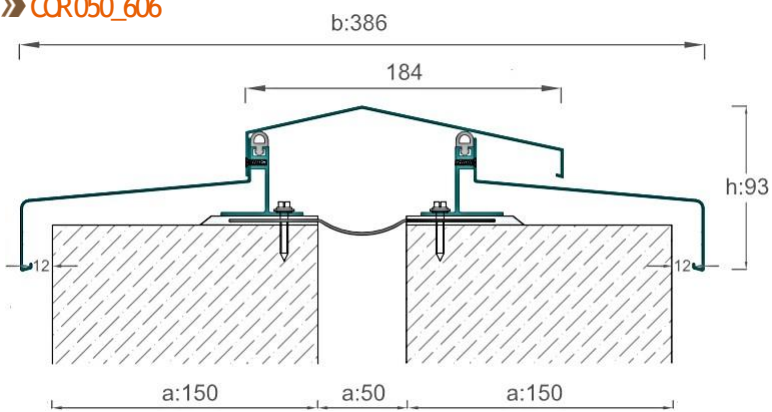

» CCR050_606

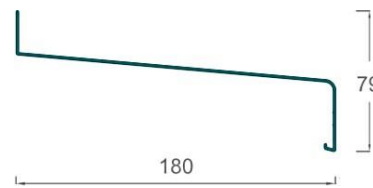
CCR050_606 15CMCCRNISA / PARAPET

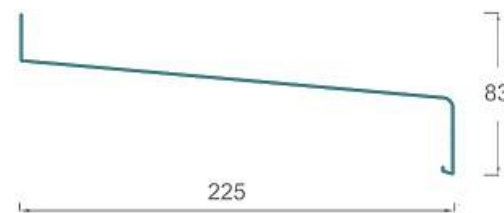

CCR051_606 20CMCCRNISA / PARAPET



CCR052_606 25CM PARAPETO / PARAPET

 Juntas de expansión
 estancas
 Complete watertight
 expansion joint profiles

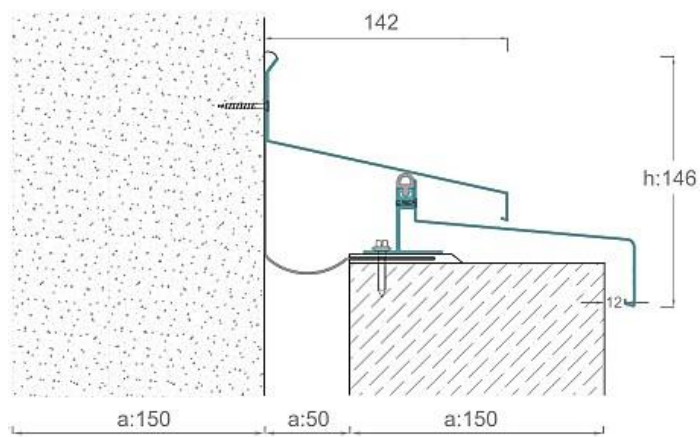
» CCR050K_606

Las juntas de la cubierta de la terraza se pueden producir de acuerdo con las dimensiones de la holgura. La estanqueidad se puede obtener mediante el perfil TPE H.
 Terrace coping profiles bottom footing can be produced according to the gap dimensions. Water tightness can be obtained by TPE H profile.

REF	DESCRIPCIÓN DESCRIPTION	ANCHO CONJUNTO (a) mm JOINT WIDTH	SUPERFICIE VISIBLE (b) mm SURFACE VISIBLE	ALTURA (h) mm PROFILE HEIGHT	ANCHO (s) mm TOTAL WIDTH	SUPERFICIE SURFACE	CAPACIDAD DE MOVIMIENTO (mm) MOVEMENT CAPACITY
COR_050_606	juntas de recubrimiento para aplicaciones de terraza Coping profiles for terrace applications	50	386	93	386	Aluminio anodizado / Pintura recubierta de polvo Anodized aluminum / Powder coated paint	± 25
COR_100_606	juntas de recubrimiento para aplicaciones de terraza Coping profiles for terrace applications	100	436	93	436	Aluminio anodizado / Pintura recubierta de polvo Anodized aluminum / Powder coated paint	± 50
COR_150_606	juntas de recubrimiento para aplicaciones de terraza Coping profiles for terrace applications	150	486	93	486	Aluminio anodizado / Pintura recubierta de polvo Anodized aluminum / Powder coated paint	± 50
COR_200_606	juntas de recubrimiento para aplicaciones de terraza Coping profiles for terrace applications	200	536	93	536	Aluminio anodizado / Pintura recubierta de polvo Anodized aluminum / Powder coated paint	± 50
COR_250_606	juntas de recubrimiento para aplicaciones de terraza Coping profiles for terrace applications	250	586	93	586	Aluminio anodizado / Pintura recubierta de polvo Anodized aluminum / Powder coated paint	± 50
COR_300_606	juntas de recubrimiento para aplicaciones de terraza Coping profiles for terrace applications	300	636	93	636	Aluminio anodizado / Pintura recubierta de polvo Anodized aluminum / Powder coated paint	± 50

Juntas de movimiento
Movement joint profiles

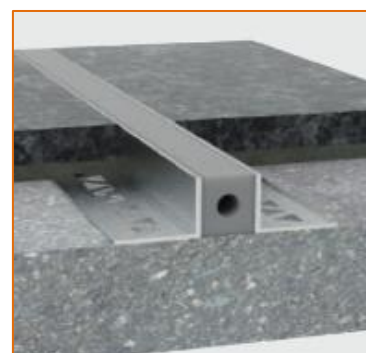
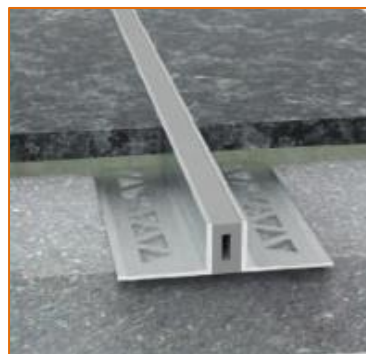
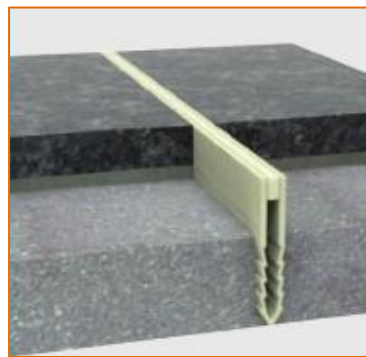

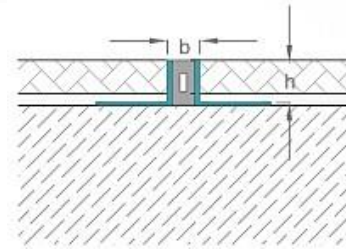

 Perfiles de juntas de movimiento
 Movement joint profiles

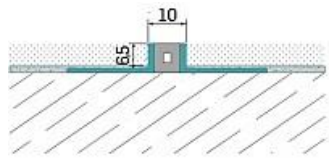
>> CCR01_06 DP

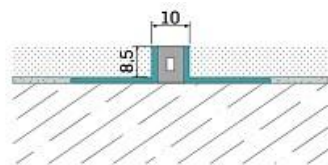

>> CCR01_08 DP



>> CCR01_10 DP

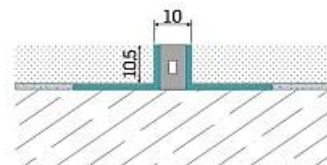

>> CCR01_12 DP

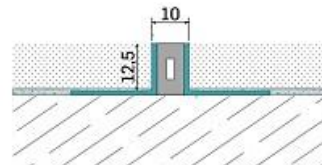

>> POR QUÉ SE UTILIZAN UNIONES DE MOVIMIENTO? / WHY MOVEMENT JOINT PROFILES ARE USED?

Las aplicaciones en cerámica, granito, porcelana, piedra, cerámica vítrea, hormigón y mármol, los revestimientos de terrazo requieren juntas de expansión térmica para absorber movimientos naturales. La diferencia de temperatura causa expansión y contracción en el agua o recubrimientos de humedad, por lo que todas las baldosas se encogen con secado y enfriamiento. Otra razón, las cargas estructurales dinámicas causan vibraciones y grandes movimientos en aplicaciones de baldosas. Si la junta de expansión no se utiliza en aplicaciones de baldosas, cerámica, granito o mármol, las tensiones internas debidas a la expansión interna o la contracción pueden causar muchos problemas, como grietas y roturas obvias. Por lo tanto, el diseño de la junta es extremadamente significativo para la vida útil de los recubrimientos.

Ceramic, granite, porcelain, stone, glassy ceramics, concrete and marble tiles and terrazzo floor cover applications require thermal expansion joints profiles to absorb natural movements. The temperature difference causes expansion and shrinkage in water or moisture coatings thus, all the tiles shrink with drying and cooling. Another reason, dynamic, structural loads cause vibration and large movements in the tile applications. If expansion joint it not used in tile, ceramic, granite or marble applications, internal stresses due to expansion or internal shrinkage can cause many problems such as, obvious cracks and breakage. Therefore, joint design extremely significant for the life of the coatings.

>> NORMAS DE APLICACIÓN / APPLICATION STANDARDS

Zona de aplicación Application area	Superficie mínima de aplicación m ² Minimum application	Máximo área de aplicación m ² Maximum application	Ancho de la junta de movimiento (taladro de elastómero) Movement joint width (Elastomer bit)
Áreas internas Internal areas	4,80 mt * 4,80mt	6,00 mt * 6,00 mt	6mm
Áreas internas (zonas húmedas y iluminadas por el sol) Internal areas (moist and sun lighted areas)	3,60 mt * 3,60 mt	4,80 mt * 4,80 mt	6mm
Al aire libre External areas	2,40 mt * 2,40 mt	3,60 mt * 3,60 mt	10mm
Al aire libre (diferencias de temperatura más calientes y frías > 40C) External areas (hottest and coldest temperature differences > 40C)	2,40 mt * 2,40 mt	3,60 mt * 3,60 mt	13mm



» CCR01_14 DP

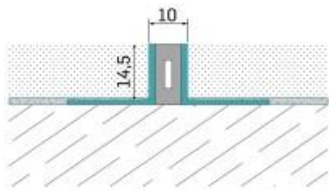

» CCR01_16 DP

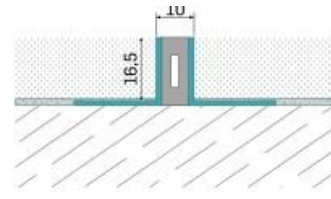

» CCR01_23 DP

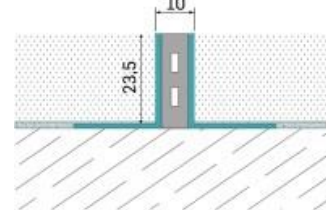

» CCR01_60 DP

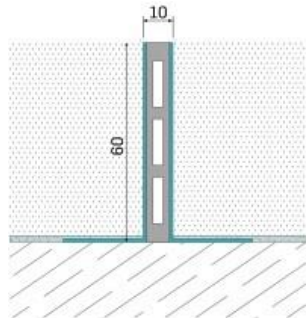

» CCR B_14 DP

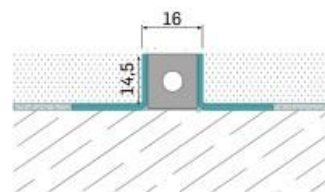

» CCR01_25 DP

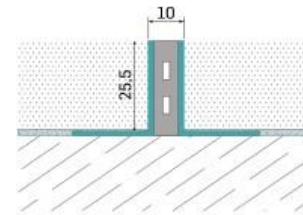

Perfiles de juntas de movimiento
Movement joint profiles



REF	SUPERFICIE VISIBLE (b) mm SURFACE VISIBLE	ALTURA (h) mm PROFILE HEIGHT	CAPACIDAD DE MOVIMIENTO mm MOVEMENT CAPACITY
COR_01_06 DP			
COR_01_08 DP			
COR_01_10 DP			
COR_01_12 DP			
COR_01_14 DP			
COR_01_16 DP			
COR_01_23 DP			
COR_01_25 DP			
COR_01_60 DP			
COR_13-14 DP			

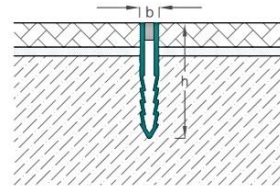
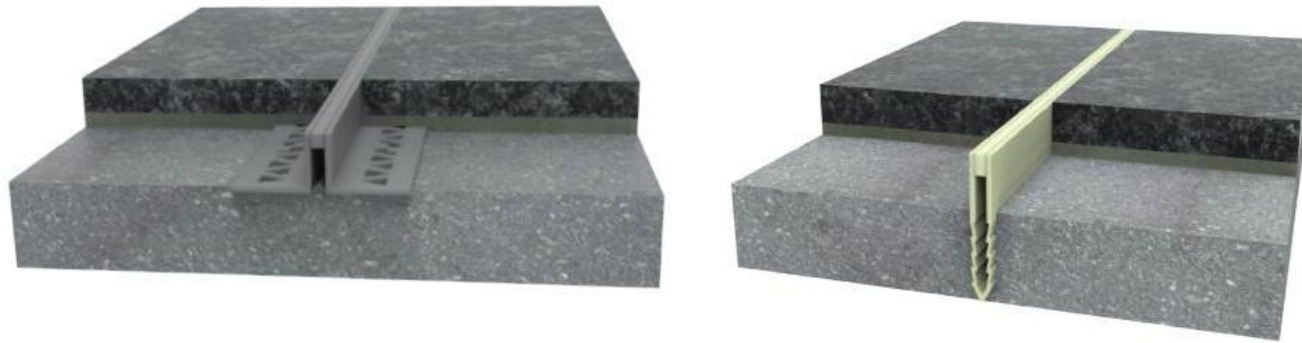

Perfiles de juntas de movimiento
Movement joint profiles

»» COR02_10 DP

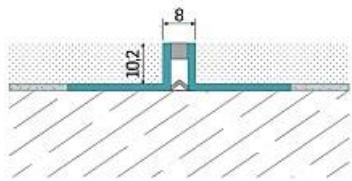

»» COR02_12 DP

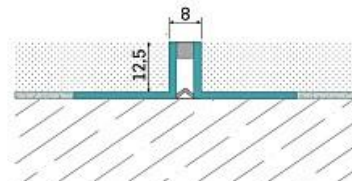

»» COR02_15 DP

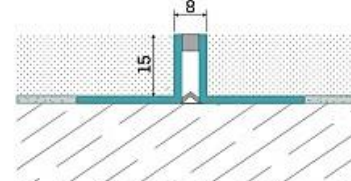

»» COR06 DP

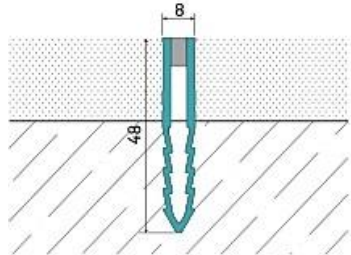

»» COR06-1DP

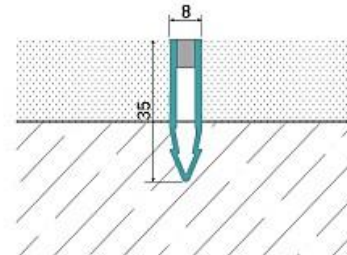

REF	SUPERFICIE VISIBLE (b) mm SURFACE VISIBLE	ALTURA (h) mm PROFILE HEIGHT	CAPACIDAD DE MOVIMIENTO mm MOVEMENT CAPACITY
COR_02_10 DP	8	10,5 + 1,2	± 2
COR_02_12 DP	8	12,5 + 1,2	± 2
COR_02_15 DP	8	15 + 1,2	± 2
COR_06 DP	8	48	± 2
COR_06-1DP	8	35	± 2

Stainless Steel
304 Quality



»» COR_08_12 DP

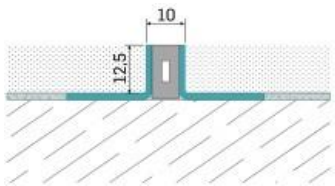

»» COR_08_14 DP

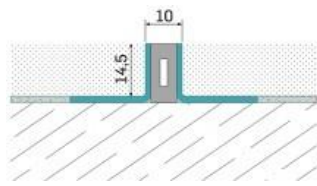

»» COR_08_16 DP

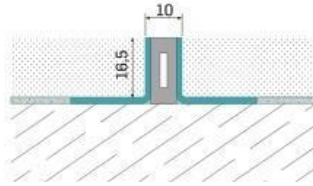

»» COR_08_23 DP

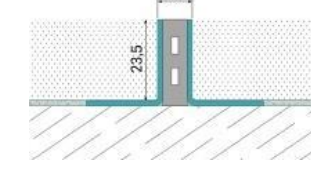

Perfiles de juntas de movimiento
Movement joint profiles

»» COR_08_30 DP

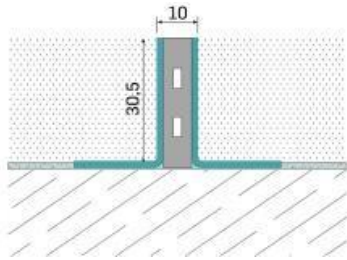

»» COR_11 DP

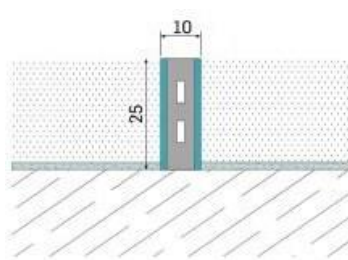

»» COR_14_14 DP

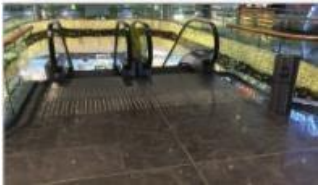
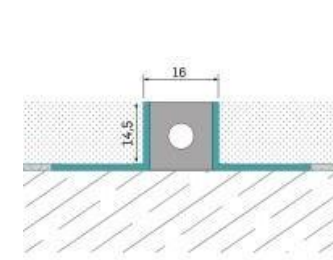

REF	SUPERFICIE VISIBLE (b) mm SURFACE VISIBLE	ALTURA (h) mm PROFILE HEIGHT	CAPACIDAD DE MOVIMIENTO mm MOVEMENT CAPACITY
COR_08_12 DP			
COR_08_14 DP			
COR_08_16 DP			
COR_08_23 DP			
COR_08_30 DP			
COR_11 DP			
COR_14_14 DP			

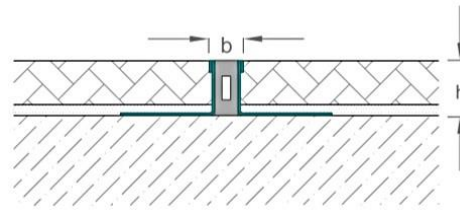
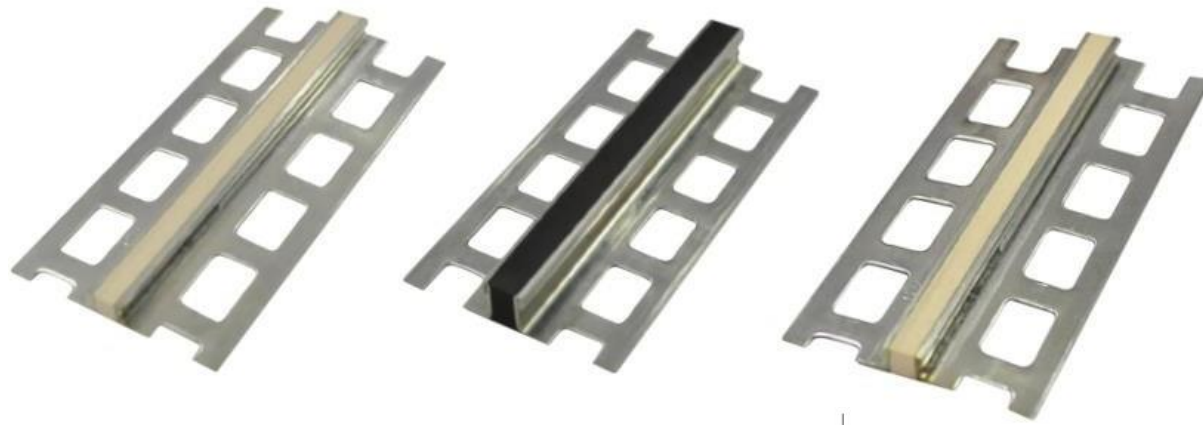

Perfiles de juntas de movimiento
Movement joint profiles

»» COR09_04 DP

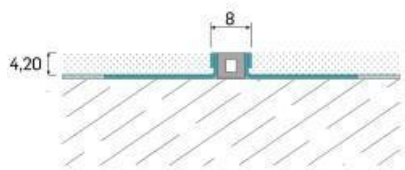

»» COR09_06 DP

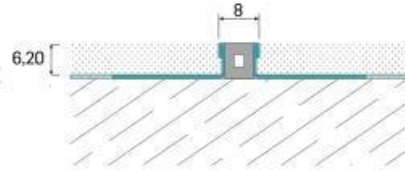

»» COR09_08 DP

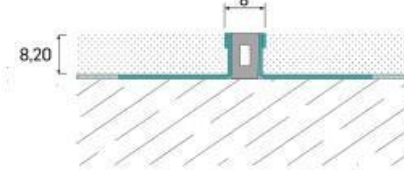

»» COR09_10 DP

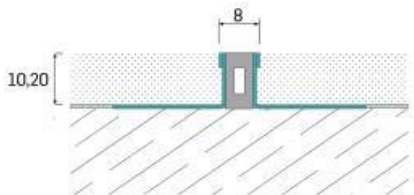

»» COR09_12 DP

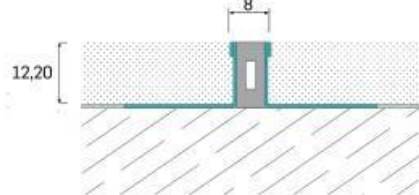

»» COR09_20 DP

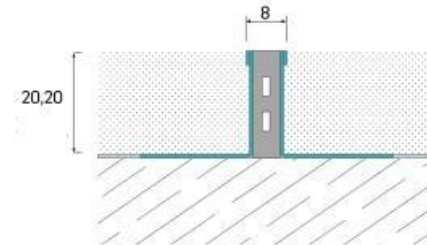

REF	SUPERFICIE VISIBLE (b) mm SURFACE VISIBLE	ALTURA (h) mm PROFILE HEIGHT	CAPACIDAD DE MOVIMIENTO mm MOVEMENT CAPACITY
COR_09_04 DP	8	4,20 + 0,8	+5/-3
COR_09_06 DP	8	6,20 + 0,8	+5/-3
COR_09_08 DP	8	8,20 + 0,8	+5/-3
COR_09_10 DP	8	10,20 + 0,8	+5/-3
COR_09_12 DP	8	12,20 + 0,8	+5/-3
COR_09-12 DP	8	20,20 + 0,8	+5/-3

Juntas de control de contracción y dilatación
Shrinkage and crack control joint products

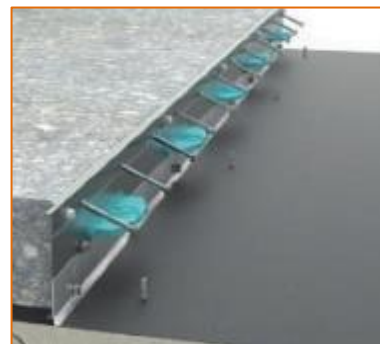
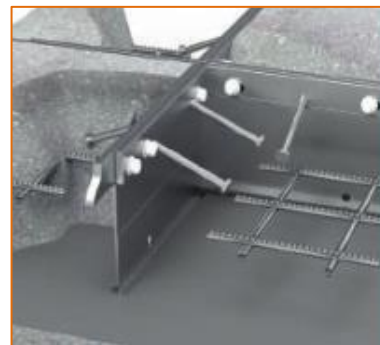
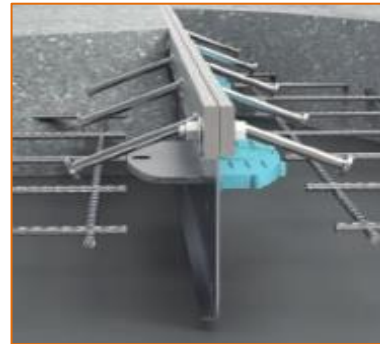
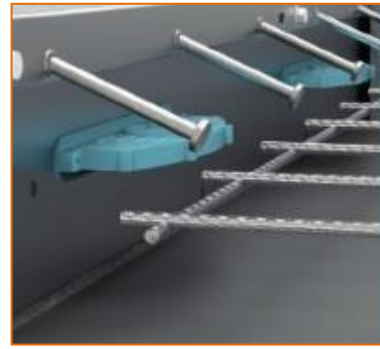

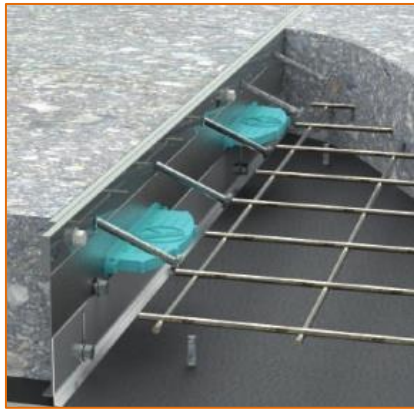

» JUSTO DESPUÉS DE VERTER EL CEMENTO
RIGHT AFTER POURING CONCRETE



» 2-3 SEMANAS DESPUÉS DE QUE SE DERRAMARA EL CEMENTO
2-3 WEEKS AFTER POURED CONCRETE

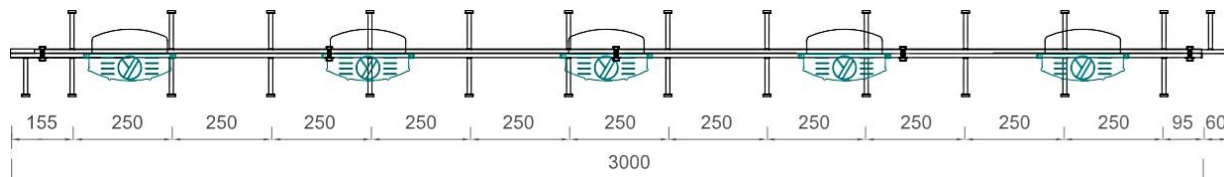

» PLAN / PLAN

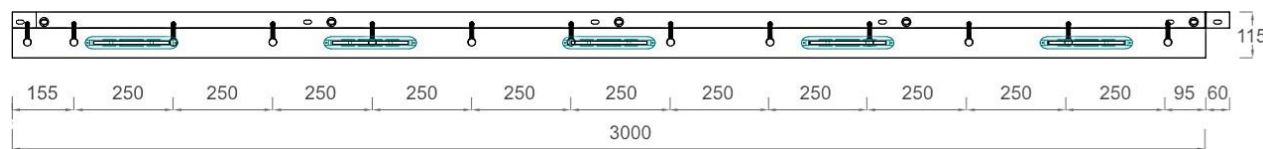

» VISTA FRONTAL / FRONT VIEW

Perfiles de juntas de control
de contracción y grietas
Shrinkage and crack control
joint profiles

Las juntas de expansión de losas son juntas de expansión de acero que prolongan la vida útil de las losas de hormigón que pretenden transportar cargas elevadas. Las juntas de losa se pueden aplicar fácilmente a los pisos industriales para minimizar el agrietamiento incontrolado. Las superficies de las juntas de losa se producen como acero galvanizado en caliente y acero inoxidable (Clase SS 304) de serie.

Slab expansion joints are steel expansion joints that extend the service life of concrete slabs which intend to carry high loads. Slab joints can easily be applied in industrial floors to minimize uncontrolled crack formation. Slab joints surfaces are produced as hot dip galvanized steel and stainless steel (SS 304 grade) as standard.

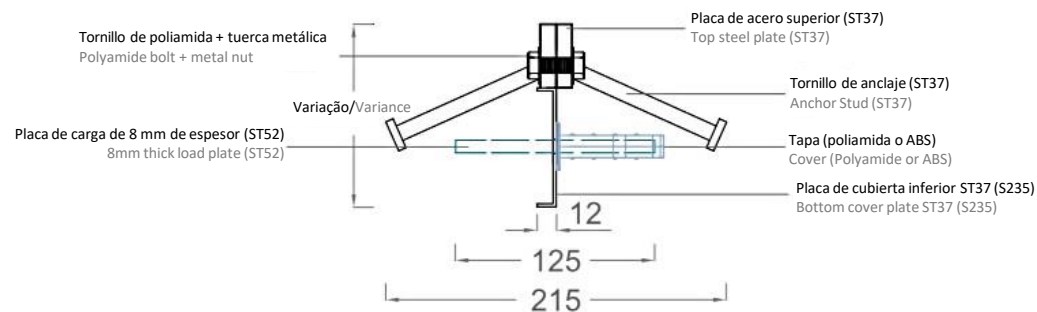

REF	LONGITUD DE LA UNIÓN DE LOSA (mm) SLAB JOINT LENGTH	ALTURA CONJUNTA DE LOSA (mm) SLAB JOINT HEIGHT	PROFUNDIDAD RECOMENDADA (mm) RECOMMENDED DEEPNESS	CENTRO DE LA PLACA DE CARGA CENTRE OF THE LOAD PLATE
COR_115 SJ				
COR_140 SJ				
COR_165 SJ				
COR_185 SJ				
COR_235 SJ				
COR_285 SJ				



Perfiles de juntas de control
de contracción y grietas
Shrinkage and crack control
joint profiles

Tradicionalmente, el hormigón de la losa se corta 24 horas después que el hormigón se ha vertido en anchuras de 24 a 30 veces el espesor del hormigón de la losa. La contracción interna del hormigón comienza a ocurrir después de 4 a 18 horas, que se produce entre los puntos débiles del cemento y los agregados.

Traditionally, the slab concrete gets cut 24 hours after the concrete, has been poured at widths of 24 to 30 times the thickness of the slab concrete. Internal shrinkage in the concrete starts happening after 4 to 18 hours which occurs in between the weak points of cement and aggregates.

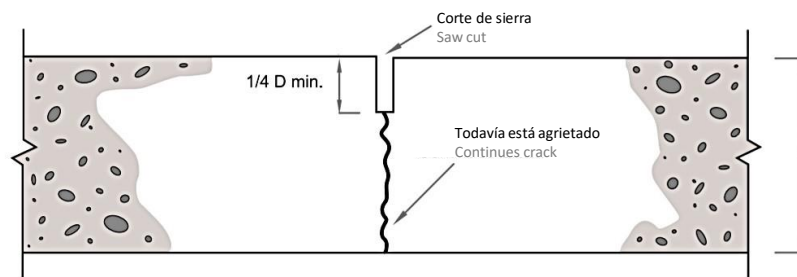

» EL COMPORTAMIENTO DEL HORMIGÓN DE LA LOSA DESPUÉS DE UN CORTE / SLAB CONCRETE BEHAVIOUR AFTER A CUT

La junta de losa proporciona una reacción perfecta durante las fugas de hormigón. Para lograr este rango de líneas deseado, se crean líneas débiles en ubicaciones predeterminadas para realizar grietas simétricas. Además, para evitar el movimiento vertical y proporcionar una transferencia de carga horizontal en estas holguras, el ST52 se utiliza en intervalos de 600 mm con placas de acero móvil de 8 mm en los rodillos. La brecha se produce entre el día 1 y la semana 3 sin necesidad de más cortes o moldes.

Slab joint provides a neat joint gap during concrete pouring. To achieve this desired line gap, weak lines are created at predetermined locations to make symmetric cracks. Furthermore, to prevent vertical movements and provide horizontal load transfer in these gaps, ST52 is utilized by 600mm intervals with movable 8mm steel plates in bearings. The gap then occurs between day 1 to week 3 without requiring additional cuts or molds.

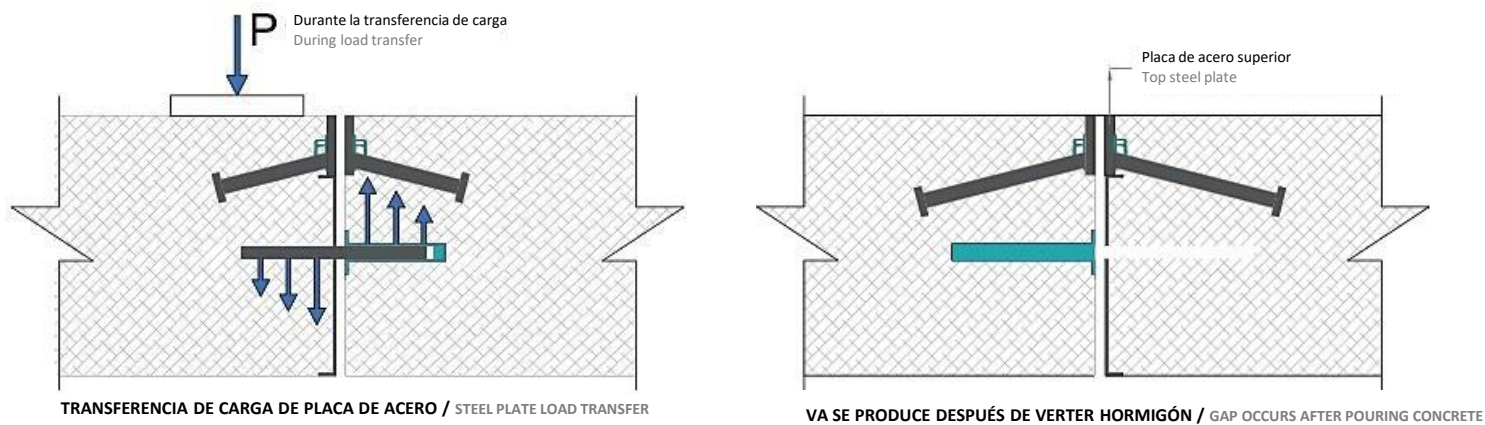

La unión de losa proporciona espacios más pequeños que los métodos tradicionales. También proporciona intervalos de 25 a 30 m en lugar de 5x5m. Esto significa que la cantidad total de brechas se reduce en aproximadamente 10 veces. El American Concrete Institute (ACI) recomienda productos de juntas de placas en lugar de cortes tradicionales.

Slab joint provides smaller gaps than traditional methods. Also provides 25m to 30 m interval gaps instead of 5x5m. This means the total quantity of gaps reduce by approximately 10 times. American concrete institute (ACI) recommends slab joint products instead of traditional cuts.



Existen dos estrategias para prevenir grietas en la superficie del hormigón:

- 1- Aumentar la cantidad de refuerzo de acero para evitar grietas aleatorias. Cuando las grietas están firmemente reforzadas por el acero, las piezas agregadas transfieren la carga en el otro lado de las pequeñas grietas. Por lo tanto, la carga se distribuye uniformemente. Sin embargo, el uso de demasiado refuerzo de acero en la losa de hormigón puede crear una vista desagradable de la malla de acero en la superficie superior.
- 2 - La forma más común es utilizar productos de control de dilatación y contracción. De esta manera, las grietas se ven obligadas a ocurrir en un lugar como una línea firme, por lo que la vista en la superficie se ve mucho más decorativa.

Los productos de dilatación industrial y control de contracción minimizan las grietas inesperadas y son capaces de transportar cargas pesadas. Adecuado para losas industriales y losas de hormigón.

Las grietas inesperadas se evitan con el hueco de aislamiento alrededor de las columnas.

There are two strategies of preventing cracks on concrete surface:

- 1- Increase steel reinforcement amount to avoid random cracks. When cracks are firmly reinforced by steel, aggregate pieces transfer the load on other side of the small cracks. So the load gets evenly distributed. However, using too much steel reinforcement in concrete slab can create unpleasant view of the steel mesh on the top surface.
- 2 - The most common way is to use expansion and shrinkage control products. By this way, cracks are forced to occur in one place as a firm line thus the view on the surface looks much more decorative.

Industrial expansion and shrinkage control products minimize the unexpected cracks and can carry heavy loads. Suitable for industrial slabs and concrete slabs.

Unexpected cracks are prevented with the isolation gap around the columns.



Perfiles de juntas de control
de contracción y grietas
Shrinkage and crack control
joint profiles

Barreras contra fuego y agua
Fire and water barriers

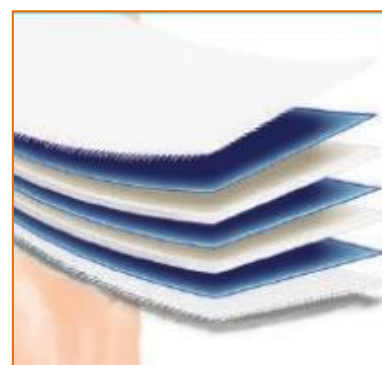
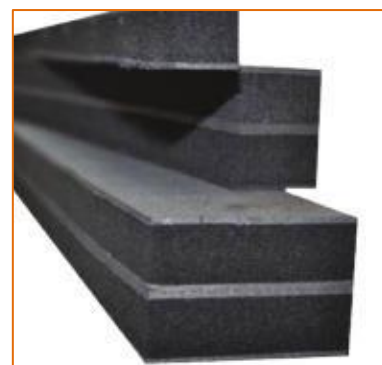

» FUEGOMANTA DE FUEGO 120 / FIRESTOP 120 FIRE BLANKET

- ✓ En anchos múltiples (FS100, FS150, FS200, FS250.FS300)/ At various widths (FS100,FS150,FS200,FS250.FS300)
- ✓ Adecuado para juntas de expansión de 10cm a 40cm/ Suitable to expansion joint gaps from 10cm to 40cm
- ✓ Fácilmente aplicable / Easily applicable
- ✓ Perfil de montaje galvanizado / Galvanized assembly profile
- ✓ Probado según BS 476: Parte 20/22 / Tested according to BS 476: Part 20/22
- ✓ Activo en 120 minutos / Active on 120 minutes
- ✓ Evitar la transferencia de calor durante 30 minutos / Preventing heat transfer for 30 minutes
- ✓ La longitud de producción es de 7 metros / Production length is 7 meter

La Firestop 120 es una manta anti-incendios de fibra de vidrio de 7 capas de alto rendimiento y bajo peso diseñada para evitar el paso de fuego y humo a través de las juntas de expansión y también evita la transferencia de calor y la transición de llamas al lado frío.

Firestop 120 is a high performance, low weight, 7 layer fiberglass fire blanket that is designed to prevent fire and smoke passage in expansion joint gaps and also prevents heat transfer and flame transition to cold side.



30 Minutos de Aislamiento
Minutes Isolation

120 Minutos de Integridad
Minutes of integrity

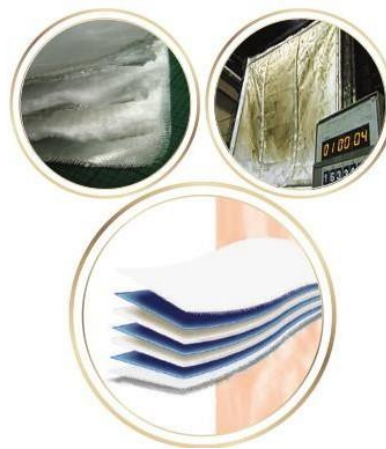

Barrera contra el fuego y el agua
Fire and water barrier

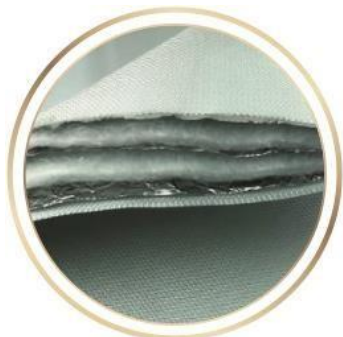
» CORTES DE MANTAS DE FUEGO- DETALLE DE LA UNIÓN / FIRE BLANKET- JOINING DETAIL

Se puede aplicar fácilmente con una grapadora
Can easily be applied a stapler

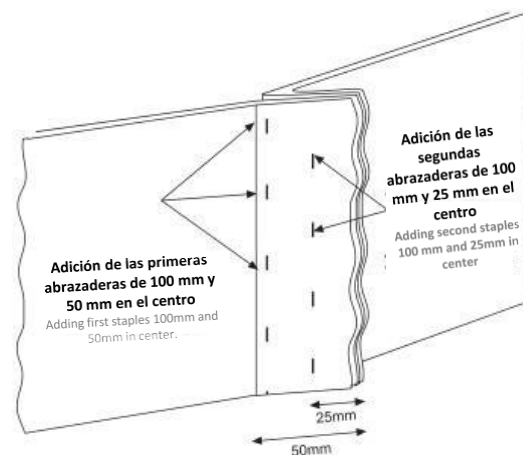



» Aplicación de barrera contra incendios bajo perfil de junta de dilatación /
 Fire barrier application under expansion joint profile

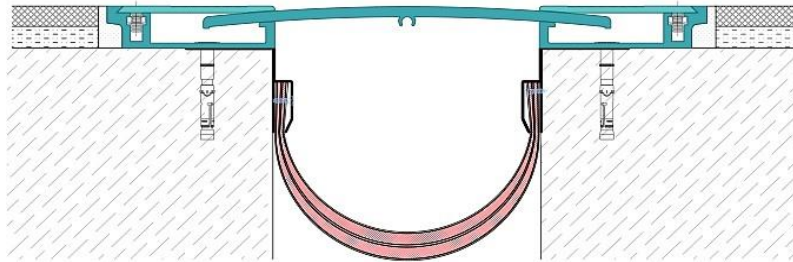

Las barreras contra incendios se pueden aplicar más fácil y rápido que las soluciones tradicionales. Las barreras contra incendios han sido diseñadas y probadas para soportar el fuego durante más tiempo cuando se montan correctamente.

Se puede utilizar en intervalos verticales y horizontales de 100 mm a 400 mm. Adecuado para aplicaciones de suelo y pared. Se puede utilizar un aerosol líquido adicional para evitar el humo del fuego.

Zonas de aplicación: Estacionamientos, hospitales, centros comerciales, colegios, bibliotecas y etc.

Fire barriers can be applied easier and faster than traditional solutions. Fire barriers have designed and tested to resist fire longest when mounted properly.

Can be used in vertical and horizontal gaps from 100mm to 400mm . Suitable for floor and wall applications. Additional liquid spray can be used to prevent fire smoke.

Application areas: Carparks, hospitals, shopping centres, schools, library and etc.

Barrera contra el fuego y el agua
 Fire and water barrier

» Aplicación de la barrera contra incendios /
 Fire barrier application

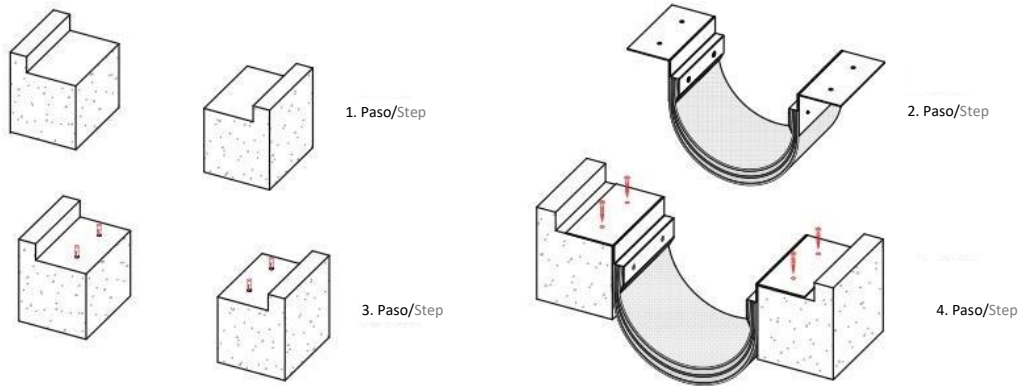

-Premontado en perfiles de acero / Preassembled to the steel profiles

REF	DESCRIPCIÓN DESCRIPTION	ANCHO DE BARRERA BARRIER WIDTH	LONGITUD (METRO/METER) LENGTH
COR_50 FS			
COR_100 FS			
COR_150 FS			
COR_200 FS			
COR_250 FS			
COR_300 FS			
COR_350 FS			
COR_400 FS			

Relleno de juntas multi-revestidas Multi coated fire stopping gap filler



» LLENADO DE JUNTAS CON MÚLTIPLES PARADAS DE FUEGO / MULTI COATED FIRE STOPPING GAP FILLER

- ✓ Producido en cubos de 5 litros y 15 litros / Produced in buckets of 5 liter and 15 liter
- ✓ Densidad 1,35 kg / dm³ / Density 1,35 kg/dm³
- ✓ Temperatura de almacenamiento ideal: 5.30C, la vida útil mínima es de 1 año / Ideal storage temperature: 5.30C, minimum shelf life is 1 year
- ✓ Temperatura de aplicación: 5.30C / Application temperature: 5.30C
- ✓ Tiempo de secado: 2-4 horas / Drying time: 2-4 hours
- ✓ Espesor recomendado: Espesor de la placa húmeda 2mm / Recommended thickness: Wet sheet thickness 2mm, Dry sheet
- ✓ Grueso: 1mm / thickness: 1mm
- ✓ Uso: 1,4 lt / m² / Usage: 1,4 lt/m²
- ✓ Color: blanco / Color: white
- ✓ Impermeable. (Limitado al 25% de la capacidad de manipulación) / Waterproof. (Limited to 25% movement capacity)
- ✓ Nota: La lana de roca debe comprimirse un 33% antes de encajar en el espacio de la junta de expansión / Note: Rockwool needs to be compressed 33% before fitting in to expansion joint gap

Este producto es un agente de llenado de acrílico a base de agua con múltiples capas de recubrimiento contra incendios. Se aplica en lana de roca por rollo o spray, interna o externamente. El llenado de la junta tiene una capacidad de movimiento del 25% de la junta aplicada y puede soportar el fuego hasta 2 horas.

This product is multi coated water based acrylic fire stopping gap filler. Applied on rock wool by a roll or spray internally or externally. Fire stopping gap filler has 25% movement capacity of gap applied in and can resist to fire up to 2 hours.

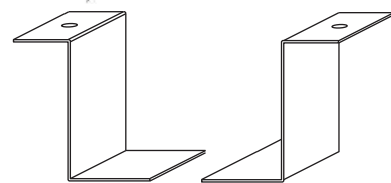
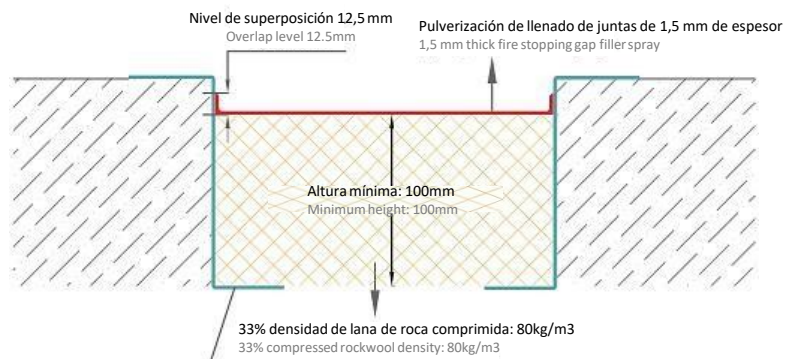

SopORTE galvanizado utilizado en anchuras de juntas de expansión (opcional)
Galvanized bracket used in wide expansion joint gaps (optional)

Barrera contra el fuego y el agua
Fire and water barrier

» TABLA DE USO (Calculado a 3 mm de espesor para alcanzar 1,5mm) USAGE TABLE (calculating on the assumption of 3 mm thickness to actually achieve 1.5mm)

ANCHO DE ESPACIO (mm) GAP WIDTH	ANCHO TOTAL CON UN NIVEL DE SUPERPOSICIÓN ADICIONAL DE 12,5 MM (mm) TOTAL WIDTH WITH ADDITIONAL 12,5MM OVERLAP LEVEL	DISTANCIA DE GAP CUBIERTA CON 1 BUCKET DE PRODUCTO CON COATINGS VARIOS (metro) GAP DISTANCE COVERED BY USING 1 BUCKET OF MULTI COATED PRODUCT (meter)
25	50	110
50	75	75
75	100	55
100	125	45
150	175	35
200	225	30



Sistema de barrera contra incendios Fire barrier systems

» SELLADOR INTUMESCENTE / INTUMESCENT GAP SEALANT

El sellador acrílico, flexible y fácil de aplicar (ampliado con calor) se utiliza a intervalos de unión máximos de 35 mm. No se endurece a temperatura exterior.

Se expande 4 veces más del tamaño original cuando se somete al calor, evita la permeabilidad al fuego.

Previene el humo y los gases nocivos durante 4 horas.

Acrylic, flexible, easily applicable sealant (expanded with heat) is used in maximum 35mm joint gaps.

Doesn't harden in outdoor temperature. Expands 4 times larger than original size when subjected to heat, prevents fire permeability. Prevents smoke and harmful gases for 4 hours.

- ✓ Sellador acrílico flexible, a base de agua, hinchazón / Flexible, water based, swelling, acrylic sealant
- ✓ Adecuado para los estándares de la BS476 Parte 20/22, BS / EN 1363-1 e BS / EN 1366-1
Suitable to standards of BS476 Part 20/22, BS/EN 1363-1 & BS/EN 1366-1
- ✓ Resistente al fuego durante 4 horas / Resistant to fire for 4 hours
- ✓ Flexibilidad a largo plazo / Long-term flexible
- ✓ Excelente agarre / Excellent sticking
- ✓ La anchura máxima del espacio es de 35 mm / Maximum gap width is 35mm



» ESPONJA ELASTOMÉRICA / ELASTOMERIC GAP SPONGE

Las esponjas de relleno de articulaciones elastoméricas se expanden con calor y se utilizan para hacer que los huecos en las juntas de expansión sean resistentes al fuego.

Gap filling elastomeric sponges are expand with heat and utilized to make expansion joint gaps fire resistant.

- ✓ Resistente al fuego hasta 2 horas / Fire resistant up to 2 hours
- ✓ No se hincha por el agua / Doesn't swell by water
- ✓ Resistente al desgarro por características de hinchazón fuertes
Resistant to tearing by the strong swelling characteristics
- ✓ Adecuado para diferentes tamaños de juntas de expansión
Suitable to different sizes of expansion joint gaps
- ✓ Adecuado para aplicaciones de hormigón porly, hormigón, vigas metálicas y paredes
Suitable for porous concrete, concrete, metal beams and wall applications
- ✓ Adecuado para BS476 Part20: 1987 / Suitable to BS476 Part20:1987

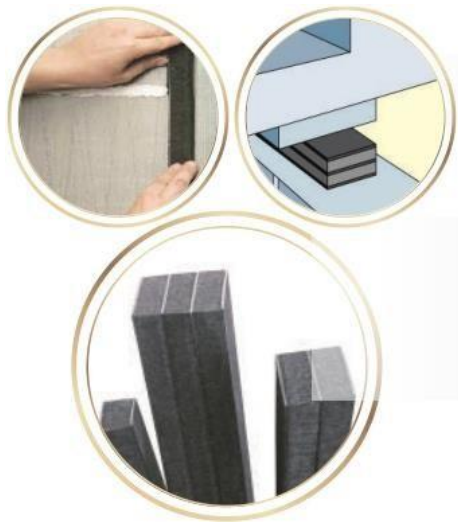

» CORDON CORTA-FUEGO DE LA DE ROCHA / ROCK WOOL FIRE ROPE

El cable Rire es un material de aislamiento de espuma y se puede aplicar fácilmente utilizando cables de vidrio en lana de roca. Se coloca en las juntas de expansión, comprimiendo al menos 33%. Se debe utilizar con spray de parada de fuego para evitar el humo.

Fire rope is a foam insulation material and can be applied easily by using glass yarn on rock wool. It is placed in expansion joint gaps by compressing at least 33%. It should be used with fire stop joint spray to prevent smoke.

- ✓ Alto rendimiento con protección contra incendios superior
High performance with superior fire protection
- ✓ Característica de aislamiento térmico / Thermal insulation feature
- ✓ Se puede aplicar fácilmente con su propiedad no inflamable
It can be applied easily with its non-flammable property
- ✓ La función de insonorización está disponible / Sound insulation feature is available
- ✓ Tiene un bajo coeficiente de conductividad térmica
It has low thermal conductivity coefficient
- ✓ Consistencia biológica / Biological consistency
- ✓ Tiene una consistencia volumétrica / It has a volumetric consistency
- ✓ Es un producto químicamente neutralizado / It is chemically neutralized product
- ✓ Excelente rendimiento debido a sus propiedades repelentes al agua
Excellent performance due to its water repellent properties
- ✓ Es un producto con alta flexibilidad / It is a product with high flexibility



Barrera contra el fuego y el agua
Fire and water barrier



**HYDRO
FLEX**

**PRODUCTOS DE
AISLAMIENTO DE AGUA
Water isolation products**



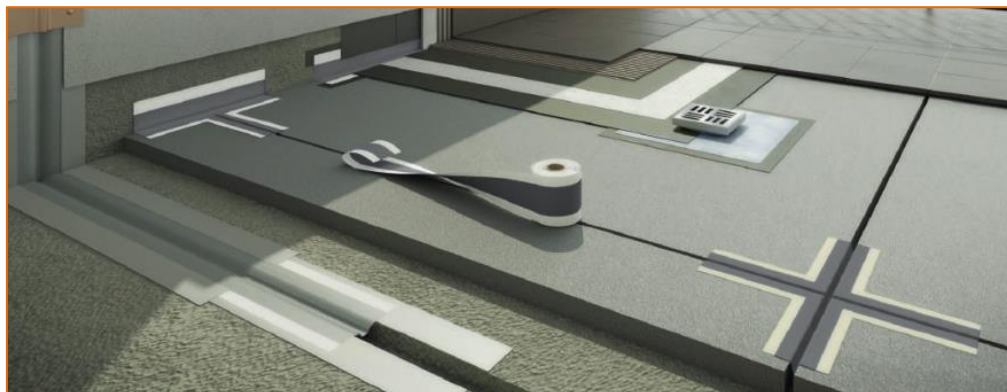

La cinta de dilatación HIDROFLEX altamente elástica se utiliza para todo tipo de edificios en huecos aislantes en la junta de expansión, brechas térmicas y grietas. Las opciones alternativas están disponibles sin orificios o con orificios de 150 mm, 200 mm, 250 mm, 300 mm, 400 mm de ancho y 1 mm, 1,5 mm de espesor.

Highly elastic HIDROFLEX expansion joint tape is used for every type of buildings in isolating expansion joint gaps, thermal gaps and cracks. Alternative options are available for without holes or with holes at 150mm, 200mm, 250mm, 300mm, 400mm width and 1mm, 1,5mm thickness.

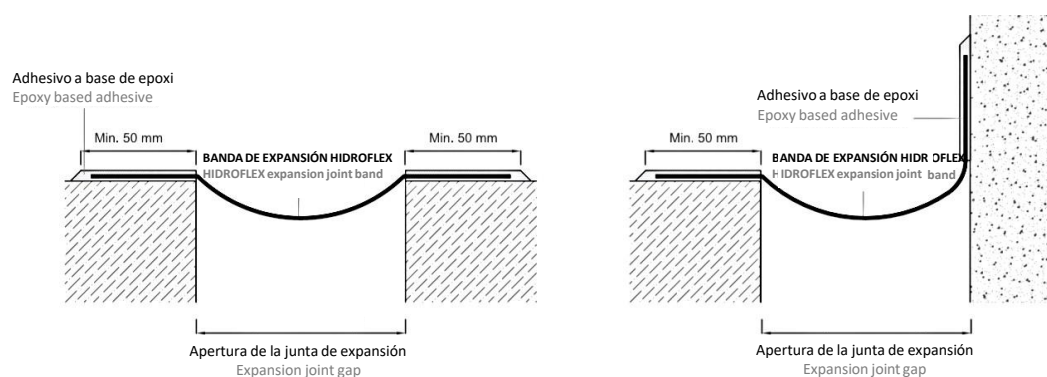
 Barrera contra el fuego y el agua
 Fire and water barrier

ESPECIFICACIONES Y VENTAJAS / SPECIFICATIONS AND ADVANTAGES

- Fácil aplicación con adhesivo epoxi. / Easy application with epoxy adhesive.
- Característica altamente elástica (600%) / Highly elastic characteristic (600%)
- Fuerte adhesión al hormigón, el acero y muchos otros materiales de construcción. / Strong adhesion to concrete, steel and many other building materials.
- Resistente a las raíces de las plantas / Resistant to plant roots
- Resistente a los rayos UV y al aceite. / UV and oil resistant.
- Buen rendimiento entre amplios valores de temperatura. / Good performance between wide temperature values.
- Fácil de cortar, soldar (aire caliente) y unir. / Easy to cut, weld (hot air) and joint.

ZONAS DE USO DEL HIDROFLEX / HIDROFLEX USAGE AREAS

- Aplicación horizontal y vertical en todo tipo de edificios / Horizontal and vertical application on all type of buildings
- Cimientos y cortinas de muros / Foundations and curtain walls
- Plantas de tratamiento de aguas residuales, plantas de tratamiento de agua potable, tanques de agua / Wastewater treatment plants, potable water plants, water tanks pools
- Túneles de hormigón, tuberías y cajas / Tunnels and concrete pipes and boxes
- Entre las líneas de conexión de la cimentación y el muro cortina. / Between foundation and curtain wall connection lines.

ESPECIFICACIONES TÉCNICAS DE HIDROFLEX HIDROFLEX TECHNICAL SPECIFICATIONS

Composición química Chemical composition	TPE (Elastómero termoplástico) / (thermoplastic elastomer)
Color	Cizento / Grey
Nivel de dureza Hardness level	80
Valor de temperatura de servicio Serving temperature value	-40°C / +90°C
Valor de temperatura térmica Thermal temperature value	270°C
Alargamiento en el descanso Elongation at break	600%
Resistencia a las lágrimas Tear strength	>600N/cm
Valor resistente a la presión del agua Water pressure resistant value	>8 Barra/Bar
Resistencia a la tracción Tensile strength	>6 Mpa
Resistencia a los rayos UV UV resistance	>7500 h
Resistencia al betún Bitumen resistance	Bien / Good
Resistencia al ácido sulfúrico Sulfuric acid resistance	Bien / Good
Resistencia al alcohol Alcohol resistance	Bien / Good
Resistencia al detergente Detergent resistance	Bien / Good

REF	ANCHO WIDTH	GRUESO THICKNESS	LONGITUD LENGTH
HIDROFLEX 150	150	1 mm & 1.5mm	25mt Rolo/ Roll
HIDROFLEX 200	200	1 mm & 1.5mm	25mt Rolo/ Roll
HIDROFLEX 250	250	1 mm & 1.5mm	25mt Rolo/ Roll
HIDROFLEX 300	300	1 mm & 1.5mm	25mt Rolo/ Roll
HIDROFLEX 400	400	1 mm & 1.5mm	25mt Rolo/ Roll

» 1º Paso / 1st step



» 2º Paso / 2nd step



» 3º Paso / 3rd step



» 4º Paso / 4th step

 Barrera contra el fuego y el
 agua
 Fire and water barrier

» ZONA DE APLICACIÓN / APPLICATION AREA

Pegado de juntas de dilatación con cinta adhesiva que ancla las varillas y barras al hormigón, piedra o ladrillo. Reparación y aislamiento de grandes grietas.
 Bonding of expansion joints tape anchoring the rods and bars to the concrete, stone or brick. Repair and isolation of wide cracks.

» ESPECIFICACIONES Y VENTAJAS / SPECIFICATION AND ADVANTAGES

Adición perfecta al hormigón y al acero, resistente a los productos químicos, libre de disolventes. Se puede aplicar en todo tipo de grietas de juntas de expansión, impermeable al agua y gas, perfecta idoneidad a superficies húmedas de hormigón, fácil de aplicar, sin imprimación necesaria antes de la inscripción.

HIDROFLEX 21 es una composición de 2 materiales a base de epoxi. Se utiliza para la fijación, anclaje y encolado.

Perfect adhesion to the concrete and steel resistant to chemicals solvent free, It can be applied all types of expansion joint gap, water and gas impermeable, perfect adhesion to the damp surfaces on concrete, easy to apply, it doesn't need any primer before application.

HIDROFLEX 21 is a composition of 2 epoxy-based material. Used for fixing, anchoring and sticking purposes.

 ESPECIFICACIONES TÉCNICAS DEL ADHESIVO DE DILATACIÓN BASADO EN EPOXI
 TECHNICAL SPECIFICATIONS OF EPOXY BASED DILATATION ADHESIVE

Número de componentes Number of components	2 componentes A y B / 2 components A and B
Especificaciones químicas Chemical specifications	Componente A - Resina Epoxi / A component - epoxy resin Componente B - Endurecedor epoxi / B component - epoxy hardener
Tasa mixta - peso A/B Mixed rate - weight A/B	3,75kg / 1,25kg
Densidad mixta Mixed density	1,7kg / lt
Totalmente curado Fully cured	Uso peatonal las 24 horas, servicio totalmente curado y abierto - 7 días Pedestrian usage 24 hours fully cured and open service - 7 days
Duración del pozo Pot life	40 dk (20C)
Tiempo de curación Curing time	Recuperable después de 8-10 horas completamente curado - 7 días Recoupable after 8-10 hours fully cured - 7 days

»» CINTA DE CÁMARA Y GRIETA / CHAMBER AND CRACK TAPE

EL HIDROFLEX 120 se utiliza para aislar puntos críticos en las esquinas de los humedales y aislar las áreas requeridas. El HIDROFLEX 120 es adecuado para muchos materiales.

HIDROFLEX 120 is used for isolation of critical point on wet area corners and isolation required areas. HIDROFLEX 120 is suitable with many of materials.

- ✓ No es necesario utilizar adhesivo adicional, ya que es compatible con cualquier tipo de material de aislamiento
- ✓ It doesn't need any extra adhesive usage as it is compatible with any kind of isolation materials
- ✓ Aplicación fácil / Easy application
- ✓ Alta capacidad de elasticidad / High elasticity capacity
- ✓ 100% impermeable / 100% waterproof
- ✓ Resistente a muchos tipos ou productos químicos / Resistant to many kind or chemicals
- ✓ Resistente a los rayos UV y al Ozono / Good resistant to Ozone and UV
- Alto rendimiento para un amplio rango de temperaturas (-40, +90°C)
High performance for wide temperature range (-40, +90°C)

Nota: Nuestra nueva banda de versión de fieltro también está disponible en el código de producto HYDROFLEX 121.
Note: Our new felt version band is also available under HYDROFLEX 121 product code.

»» BANDA DE ABSORCIÓN DE AGUA A BASE DE REGÓN DE SODIO / SODIUM BETONITE BASED WATER SWELLING BAND

Gama de dilatación de agua diseñada para llenar articulaciones o grietas en hormigón cuando se dilatan en contacto con el agua.

Water swelling band designed to fill gaps or crack in concrete by swelling in contact with water.

- ✓ Fácil de aplicar / Easy to apply
- ✓ Fácil aplicación, incluso con una gran cantidad de armaduras
Easy application even with huge amount of rebar
- ✓ Poner en la posición correcta y presionar son sólo estos pasos para el montaje en las áreas de conexión
Placing in right position and pressing are only the steps for mounting to connection areas
- ✓ La función de absorción de forma segura no permite que se inflame en cajas de hormigón filtradas
Safely swelling feature does not allow it to get swollen in pouring concrete cases
- ✓ Se puede utilizar en piscinas, túneles, metros, paredes de acantilados, muros cortina
Can be used in swimming pools, tunnels, subways, retaining walls, curtain walls
- ✓ Se puede utilizar en tanques de agua, sistemas de alcantarillado e instalaciones de purificación de agua
Can be used in water tanks, sewage systems and water purification facilities
- Juntas de hormigón, presas, carreteras y cruces antiguos y nuevos de hormigón.
Concrete joints, dams, road and intersections of old and new concretes.

»» BANDA DE ABSORCIÓN DE AGUA A BASE DE ACRÍLICO / ACRYLIC BASED WATER SWELLING BAND

La banda de absorción de agua a base de acrílico se hincha cuando está en contacto con el agua.

Las áreas de aplicación son: piscinas, tanques de agua, estaciones de alcantarillado y juntas de construcción. También aplicable en juntas frías, donde las cortinas están conectadas con cimentaciones y áreas de contacto de perfiles de acero y tuberías de hormigón. Se puede utilizar para proporcionar fuerzas también en áreas expuestas al agua de mar.

Acrylic based water stop band gets swollen when in contact with water.

Application areas are swimming pools, water tanks, sewage plants and construction joints. Also applicable in cold joints where curtains are connected with foundations and steel profile and pipe's contact areas with concrete. It can be used to provide seals in areas exposed to sea water as well.

- ✓ Fácil de aplicar / Easy to apply
- ✓ Se puede utilizar en múltiples superficies / Can be used in various surfaces
- ✓ Fácil aplicación, incluso con una gran cantidad de armaduras
Easy application even with huge amount of rebar
- ✓ La función de absorción de forma segura no permite que se inflame en cajas de hormigón filtradas
Safely swelling feature does not allow it to get swollen in pouring concrete cases
- ✓ Llena posibles huecos y grietas por hinchazón y actúa como una barrera de agua en la estructura de hormigón armado
Fills possible gaps and cracks by swelling and acts as a water barrier in the reinforced concrete structure
- ✓ Resistente al alto contenido de agua salada y a diversos productos químicos
Resistant to highly salted water content and various chemicals

 Barrera contra el fuego y el
 agua
 Fire and water barrier

Lisboa - Portugal
geral@cortartec.net
(+351) 219824133

España - Madrid
+34 917 374 005
espana@cortartec.net

Francia - Lyon
+33 975 181 167
france@cortartec.net

Perú - Lima
+51 164 192 22
peru@cortartec.net

Brasil - Rio de Janeiro
+55 2140420115
brasil@cortartec.net

Venezuela - Caracas
+58 212 720 2555
venezuela@cortartec.net

Argélia - Algiers
+213 983 200 261
algerie@cortartec.net



CE